

# EI-650 Series

240V Class 1HP~40HP

480V Class 1HP~40HP

**Read this manual carefully before installing, wiring, operating, servicing or inspecting the drive.  
Keep this manual within easy reach for quick reference.**

*Thank you for purchasing Eric-650 Variable Speed Drives!*

## Safety Instructions

- Always follow safety instructions to prevent accidents and potential hazards from occurring.

- In this manual, safety messages are classified as follows:



### **Warning**

Improper operation may result in serious personal injury or death.



### **Caution**

Improper operation may result in slight to medium personal injury or property damage.

- Throughout this manual we use the following two illustrations to make you aware of safety considerations:



Identifies potential hazards under certain conditions.  
Read the message and follow the instructions carefully.



Identifies shock hazards under certain conditions.  
Particular attention should be directed because dangerous voltage may be present.

- Keep operating instructions handy for quick reference.
- Read this manual carefully to maximize the performance of EI-650 series inverter and ensure its safe use.



## **Warning**

- **Do not remove the cover while power is applied or the unit is in operation.**  
Otherwise, electric shock could occur.
- **Do not run the inverter with the front cover removed.**

Otherwise, you may get an electric shock due to high voltage terminals or charged capacitor exposure.

- **Do not remove the cover except for periodic inspections or wiring, even if the input power is not applied.**

Otherwise, you may access the charged circuits and get an electric shock.

- **Wiring and periodic inspections should be performed at least 10 minutes after disconnecting the input power and after checking the DC link voltage is discharged with a meter (below DC 30V).**

Otherwise, you may get an electric shock.

- **Operate the switches with dry hands.**

Otherwise, you may get an electric shock.

- **Do not use the cable when its insulating tube is damaged.**

Otherwise, you may get an electric shock.

- **Do not subject the cables to scratches, excessive stress, heavy loads or pinching.**

Otherwise, you may get an electric shock.



## Caution

- **Install the inverter on a non-flammable surface. Do not place flammable material nearby.**

Otherwise, fire could occur.

- **Disconnect the input power if the inverter gets damaged.**

Otherwise, it could result in a secondary accident and fire.

- **After the input power is applied or removed, the inverter will remain hot for a couple of minutes.**

Otherwise, you may get bodily injuries such as skin-burn or damage.

- **Do not apply power to a damaged inverter or to an inverter with parts missing even if the installation is complete.**

Otherwise, electric shock could occur.

- **Do not allow lint, paper, wood chips, dust, metallic chips or other foreign matter into the drive.**

Otherwise, fire or accident could occur.

## Operating Precautions

### (1) Handling and installation

- Handle according to the weight of the product.
- Do not stack the inverter boxes higher than the number recommended.
- Install according to instructions specified in this manual.
- Do not open the cover during delivery.
- Do not place heavy items on the inverter.
- Check the inverter mounting orientation is correct.
- Do not drop the inverter, or subject it to impact.
- Use the Type 3 grounding method for 240 V Class and special Type 3 for 480V class. (Ground impedance: Below 100 ohm).
- Take protective measures against ESD (Electrostatic Discharge) before touching the PCB for inspection or installation.
- Use the inverter under the following environmental conditions:

Environment	Ambient temperature	- 10 ~ +50°C (non-freezing)
	Relative humidity	90% RH or less (non-condensing)
	Storage temperature	- 20 ~ +60°C
	Location	Protected from corrosive gas, combustible gas, oil mist or dust
	Altitude, Vibration	Max. 1,000m above sea level, Max. 9.8m/sec <sup>2</sup> (1.0G) or less

### (2) Wiring

- Do not connect a power factor correction capacitor, surge suppressor, or RFI filter to the output of the inverter.
- The connection orientation of the output cables U, V, W to the motor will affect the

direction of rotation of the motor.

- Incorrect terminal wiring could result in the equipment damage.
- Reversing the polarity (+/-) of the terminals could damage the inverter.
- Only authorized personnel familiar with RICH ELECTRIC inverter should perform wiring and inspections.
- Always install the inverter before wiring. Otherwise, you may get an electric shock or have bodily injury.

### (3) Trial run

- Check all parameters during operation. Changing parameter values might be required depending on the load.
- Always apply permissible range of voltage to the each terminal as indicated in this manual. Otherwise, it could lead to inverter damage.

### (4) Operation precautions

- When the Auto restart function is selected, stay away from the equipment as a motor will restart suddenly after an alarm stop.
- The “” key on the keypad is valid only when the appropriate function setting has been made. Prepare an emergency stop switch separately.
- If an alarm reset is made with the reference signal present, a sudden start will occur. Check that the reference signal is turned off in advance. Otherwise an accident could occur.
- Do not modify or alter anything inside the inverter.
- Motor might not be protected by electronic thermal function of inverter.
- Do not use a magnetic contactor on the inverter input for frequent starting/stopping of the inverter.
- Use a noise filter to reduce the effect of electromagnetic interference. Otherwise nearby electronic equipment may be affected.
- In case of input voltage unbalance, install AC reactor. Power factor capacitors and generators may become overheated and damaged due to potential high frequency noise transmitted from inverter.
- Use an insulation-rectified motor or take measures to suppress the micro surge voltage when driving 480V class motor with inverter. A micro surge voltage attributable to wiring constant is generated at motor terminals, and may deteriorate insulation and damage motor.

- ❑ Before operating unit and prior to user programming, reset user parameters to default settings.
- ❑ Inverter can easily be set to high-speed operations, verify capability of motor or machinery prior to operating unit.
- ❑ Stopping torque is not produced when using the DC-Break function. Install separate equipment when stopping torque is needed.

(5) Fault prevention precautions

- ❑ Provide a safety backup such as an emergency brake which will prevent the machine and equipment from hazardous conditions if the inverter fails.

(6) Maintenance, inspection and parts replacement

- ❑ Do not conduct a megger (insulation resistance) test on the control circuit of the inverter.

(7) Disposal

- ❑ Handle the inverter as an industrial waste when disposing of it.

(8) General instructions

- ❑ Many of the diagrams and drawings in this instruction manual show the inverter without a circuit breaker, a cover or partially open. Never run the inverter like this. Always place the cover with circuit breakers and follow this instruction manual when operating the inverter.

# CONTENTS

<b>USER GUIDE .....</b>	<b>1</b>
<b>1. Read first.....</b>	<b>1-1</b>
<b>1.1 Contents of the product .....</b>	<b>1-1</b>
<b>1.2 Names and functions.....</b>	<b>1-2</b>
<b>1.3 Power circuit and control circuit terminal boards .....</b>	<b>1-3</b>
<b>1.4 Notes on the application .....</b>	<b>1-5</b>
<b>1.4.1 Motors .....</b>	<b>1-5</b>
<b>1.4.2 Inverters.....</b>	<b>1-8</b>
<b>1.4.3 What to do about the leak current .....</b>	<b>1-10</b>
<b>1.4.4 Installation .....</b>	<b>1-13</b>
<b>1.5 Dimension .....</b>	<b>1-16</b>
<b>2. Connection .....</b>	<b>2-1</b>
<b>2.1 Standard connection .....</b>	<b>2-1</b>
<b>2.1.1 Standard connection diagram 1.....</b>	<b>2-1</b>
<b>2.1.2 Standard connection diagram 2.....</b>	<b>2-2</b>
<b>2.2 Description of terminals .....</b>	<b>2-3</b>
<b>2.2.1 Power circuit terminals .....</b>	<b>2-3</b>
<b>2.2.2 Control circuit terminals.....</b>	<b>2-4</b>
<b>3. Operations.....</b>	<b>3-1</b>
<b>3.1 Simplified Operation of the EI-650 .....</b>	<b>3-1</b>
<b>3.1.1 How to start and stop.....</b>	<b>3-2</b>
<b>3.1.2 How to set the frequency .....</b>	<b>3-3</b>
<b>3.2 How to operate the EI-650.....</b>	<b>3-6</b>
<b>4. Basic EI-650 operations .....</b>	<b>4-1</b>
<b>4.1 Flow of status monitor mode.....</b>	<b>4-2</b>
<b>4.2 How to set parameters .....</b>	<b>4-3</b>
<b>4.2.1 How to set the basic parameters .....</b>	<b>4-4</b>
<b>4.2.2 How to set extended parameters.....</b>	<b>4-5</b>
<b>4.2.3 Search and resetting of changed parameters U-26 .....</b>	<b>4-6</b>
<b>4.2.4 Searching for a history of changes, using the history function CU-H ...</b>	<b>4-8</b>
<b>4.2.5 Parameters that cannot be changed while running .....</b>	<b>4-9</b>
<b>4.2.6 Returning all parameters to standard default setting .....</b>	<b>4-10</b>

4.2.7	How to save / load the user setting parameters.....	4-11
5.	Table of parameters and data.....	5-1
5.1	User parameters.....	5-1
5.2	Basic parameters.....	5-1
5.3	Extended parameters.....	5-6
6.	Basic parameters.....	6-1
6.1	Setting acceleration / deceleration time.....	6-1
6.1.1	Automatic acceleration / deceleration.....	6-1
6.1.2	Manually setting acceleration / deceleratin time.....	6-2
6.2	Increasing starting torque.....	6-3
6.3	Specifying an operation mode, using parameters.....	6-6
6.4	Selection of operation mode.....	6-9
6.5	Meter setting and adjustment.....	6-11
6.6	Standard default setting and adjustment.....	6-14
6.7	Forward / reverse run selection (Operation panel operation).....	6-15
6.8	Maximum frequency.....	6-16
6.9	Upper limit and lower limit frequcies.....	6-17
6.10	Base frequency.....	6-18
6.11	Selecting control mode.....	6-18
6.12	Manual torque boost – increasing torque boost at low speeds.....	6-25
6.13	Setting the electronic thermal.....	6-25
6.14	Preset-speed operation (speeds in 15 steps).....	6-30
7.	Extended parameters.....	7-1
7.1	Input/output parameters.....	7-1
7.1.1	Low-speed signal.....	7-1
7.1.2	Output of designated frequency reach signal.....	7-2
7.1.3	Output of set frequency speed reach signal.....	7-3
7.2	Input signal selection.....	7-4
7.2.1	Priority selection (both F-CC. R-CC are ON).....	7-4
7.2.2	Changing the functions of VIA and VIB terminals.....	7-5
7.3	Terminal function selection.....	7-7
7.3.1	Keeping an input terminal function always active (ON).....	7-7
7.3.2	Modifying input terminal funcitons.....	7-7
7.3.3	Modifying output terminal funcitons.....	7-10
7.3.4	Assigning two functions to an output terminal.....	7-11
7.3.5	Comparing the frequency command values.....	7-15

<b>7.4</b>	<b>Basic parameter 2.....</b>	<b>7-16</b>
7.4.1	Switch motor characteristics via terminal input.....	7-16
<b>7.5</b>	<b>Frequency priority selection .....</b>	<b>7-17</b>
7.5.1	Using a frequency command according to the particular situation....	7-17
7.5.2	Setting frequency command characteristics.....	7-19
7.5.3	Setting of frequency with the input from an external contact.....	7-20
7.5.4	Fine adjustment of frequency setting signal.....	7-23
<b>7.6</b>	<b>Operation frequency .....</b>	<b>7-24</b>
7.6.1	Starting frequency.....	7-24
7.6.2	Run/Stop control with frequency setting signals .....	7-25
<b>7.7</b>	<b>DC braking .....</b>	<b>7-25</b>
7.7.1	DC braking .....	7-25
7.7.2	Motor shaft fixing control .....	7-26
<b>7.8</b>	<b>Auto-stop in case of lower-limit frequency continuous operation.....</b>	<b>7-27</b>
7.8.1	Auto-stop in case of lower-limit frequency continuous operation .....	7-27
<b>7.9</b>	<b>Jog run mode .....</b>	<b>7-28</b>
<b>7.10</b>	<b>Jump frequency-jumping resonant frequencies .....</b>	<b>7-31</b>
<b>7.11</b>	<b>Preset-speed operation frequencies .....</b>	<b>7-32</b>
7.11.1	Preset-speed operation frequencies 8 to 15.....	7-32
7.11.2	Fire-speed control .....	7-32
<b>7.12</b>	<b>PWM carrier frequency .....</b>	<b>7-32</b>
<b>7.13</b>	<b>Trip-less intensification .....</b>	<b>7-35</b>
7.13.1	Auto-restart (Restart of coasting motor) .....	7-35
7.13.2	Regenerative power ride-through control/Deceleration stop .....	7-37
7.13.3	Retry function.....	7-38
7.13.4	Dynamic (regenerative) braking-For abrupt motor stop.....	7-40
7.13.5	Avoiding overvoltage tripping .....	7-43
7.13.6	Output voltage adjustment / Supply voltage correction.....	7-44
7.13.7	Canceling the operation command.....	7-46
<b>7.14</b>	<b>Droop control.....</b>	<b>7-46</b>
<b>7.15</b>	<b>Braking setting functions .....</b>	<b>7-48</b>
<b>7.16</b>	<b>Conducting PID control.....</b>	<b>7-48</b>
<b>7.17</b>	<b>Setting motor constants .....</b>	<b>7-52</b>
7.17.1	Setting motor constants 1 .....	7-52
7.17.2	Setting motor constants 2 (Details).....	7-56
<b>7.18</b>	<b>Acceleration / deceleration patterns 2 and 3 .....</b>	<b>7-57</b>
7.18.1	Selecting an acceleration / deceleration pattern.....	7-57
7.18.2	Selecting an acceleration / deceleration pattern.....	7-59
<b>7.19</b>	<b>Protection functions .....</b>	<b>7-62</b>
7.19.1	Setting motor electronic thermal protection .....	7-62
7.19.2	Setting current stall.....	7-63
7.19.3	Inverter trip retention .....	7-64
7.19.4	Emergency stop .....	7-65

7.19.5	Output phase failure detection .....	7-66
7.19.6	Input phase failure detection .....	7-67
7.19.7	Control mode for small current.....	7-68
7.19.8	Detection of output short-circuit .....	7-69
7.19.9	Over-torque trip .....	7-69
7.19.10	Cumulative operation time alarm setting.....	7-71
7.19.11	Over-voltage stall protection level.....	7-71
7.19.12	Undervoltage trip .....	7-72
7.19.13	Trip at VIA low level input mode.....	7-72
7.19.14	Parts replacement alarms.....	7-73
7.20	Adjustment parameters.....	7-73
7.20.1	Pulse train output for meters .....	7-73
7.20.2	Calibration of analog outputs .....	7-75
7.21	Operation panel parameter.....	7-76
7.21.1	Prohibition of key operations and parameter settings .....	7-76
7.21.2	Changing the display unit to A / V / min <sup>-1</sup> .....	7-77
7.21.3	Displaying the rotational speed of the motor of the line speed.....	7-78
7.21.4	Changing the steps in which the value displayed changes .....	7-80
7.21.5	Changing the item displayed by default.....	7-82
7.21.6	Canceling the operation command.....	7-82
7.21.7	Selection of operation panel stop pattern .....	7-83
7.22	Communication function (Command serial).....	7-83
7.22.1	Setting of common function .....	7-83
7.22.2	Using the RS485 .....	7-86
7.23	Parameters for options .....	7-89
7.24	Parameters magnetic motors .....	7-89
8.	Monitoring the operation status .....	8-1
8.1	Status monitor mode.....	8-1
8.1.1	Status monitor under normal conditions.....	8-1
8.1.2	Display of detailed information on a past trip .....	8-4
8.2	Display of trip information.....	8-5
8.2.1	Trip code display .....	8-5
8.2.2	Display of trip information at the occurrence of a trip.....	8-6
9.	Before makinga service call-Trip information and remedies .....	9-1
9.1	Trip causes / warnings and remedies .....	9-1
9.2	Restoring the inverter from a trip.....	9-7
9.3	If the motor does not run while no trip message is displayed.....	9-9
9.4	How to determine the causes of other problems .....	9-10

<b>10.</b>	<b>Inspection and maintenance.....</b>	<b>10-1</b>
<b>10.1</b>	<b>Regular inspection.....</b>	<b>10-1</b>
<b>10.2</b>	<b>Periodical inspection.....</b>	<b>10-2</b>
<b>10.3</b>	<b>Making a call for servicing.....</b>	<b>10-5</b>
<b>10.4</b>	<b>Keeping the inverter in storage .....</b>	<b>10-5</b>

## Standard Specification

Voltage Class		220V class single-phase			220V class 3-phase										440V class 3-phase											
Model EI-650-		S1L	S2L	S3L	01L	02L	03L	05L	07L	10L	15L	20L	25L	30L	40L	01H	02H	03H	05H	07H	10H	15H	20H	25H	30H	40H
Max. Application Motor Output (HP)		1	2	3	1	2	3	5	7.5	10	15	20	25	30	40	1	2	3	5	7.5	10	15	20	25	30	40
Output Features	Rated Output Current (A)	5	8	11	5	8	11	17.5	25	33	54	66	80	96	130	3.4	4.8	5.5	8.6	14.8	18	28	33	41	52	65
	Max. Output Voltage (V)	3-phase 200~240V (Proportional to input voltage)			3-phase 200~240V (Proportional to input voltage)										3-phase 380~480V (Proportional to input voltage)											
	Max. Output Frequency (Hz)	500Hz (Programmable)																								
Power Supply	Rated Input Voltage and Frequency	Single-phase 200~240V 50/60 Hz			3-phase 200~240V 50/60 Hz										3-phase 380~480V 50/60 Hz											
	Allowable Voltage Fluctuation	-15 ~ +10%																								
	Allowable Frequency Fluctuation	±5%																								
Control Features	Control Method	Sine wave PWM (V/F control, Vector control selectable)																								
	Frequency Control Range	0.5 ~ 500.0Hz. Default: 0.5~80Hz, Max. frequency: 30~500Hz																								
	Frequency Accuracy (Temperature Change)	Digital reference :± 0.01%(-10°C ~ +50°C) Analog reference :± 0.5% (25°C ±10°C)																								
	Frequency Setting Resolution	Digital reference: 0.01Hz (less than 100Hz) , 0.1Hz(100Hz or more) Analog reference: 0.1Hz																								
	Output Frequency Resolution	0.01 Hz																								
	Overload Capacity	150% rated output current for one minute																								
	Frequency Reference Signal	DC0 ~ +10V(1~10KΩ), 4 ~ 20mA(250Ω), 0 ~ 20mA(250Ω) Frequency setting potentiometer (Selectable)																								
	Accel/Decel Time	0.0~3200sec. (3 accel/decel time are independently programmed)																								
	Braking Torque	Short-term average deceleration torque 1HP:100% or more , 2HP: 50% or more , 3HP: 20% or more Continuous regenerative torque: 20%(150% with optional braking resistor, braking transistor built-in)																								
Voltage/Frequency Characteristics	V/F constant, variable torque, automatic torque boost, vector control, automatic energy-savings, dynamic automatic energy-saving control, auto-tuning																									
Protective Features	Motor Overload Protection	Electronic thermal overload relay																								
	Instantaneous Overcurrent	Motor coasts to a stop at approx. 250% of inverter rated current																								
	Overload	Motor coasts to a stop after 1 minute at 150% of inverter rated output current																								
	Overvoltage	Motor coasts to a stop if DC bus voltage exceeds 410V(220VClass) Motor coasts to a stop if DC bus voltage exceeds 820V(440VClass)																								
	Undervoltage	Motor coasts to a stop if DC bus voltage is less than 200V(220VClass) Motor coasts to a stop if DC bus voltage is less than 400V(440V Class)																								
	Momentary Power Loss	Following items are selectable: Stops if power loss is 15ms or longer Continuous operation if power loss is approx. 0.5s or shorter Constant running																								
	Cooling Fin Overheat	Protected by electronic circuit																								
	Stall Prevention Level	Can be set individual level during accel/deccl, provided/not provided available during coast to a stop																								
	Cooling Fan Fault	Protected by electronic circuit (fan lock detection)																								
	Ground Fault	Protected by electronic circuit																								
Power Charge Indication	ON until the DC bus voltage becomes 50V or less																									

Other Functions	Multi-function input	Programmable to 76 functions such as forward/reverse run signal input, jog run signal input, operation base signal input and reset signal input, to assign to 8 input terminals. Logic selectable between SINK (Negative) (NPN) and SOURCE (Positive) (PNP)	
	Multi-function output	Programmable to 58 functions such as upper/lower limit frequency signal output, low-speed detection signal output, specified speed reach signal output and failure signal output, to assign to M relay output, open collector output and RY output terminals.	
	Dropping Function	When 2 or more inverters are used to operate a single load, this function prevents load from concentrating on one inverter due to unbalance	
	Override Function	The sum of 2 analog signals (VIA/VIB) can be used as a frequency command value	
	Digital Operator	RCU-650 is available to monitor frequency reference, output frequency, output current and fault message...etc.	
	Terminals	Main circuit: Screw terminals Control circuit: Plug-in screw terminal	
	Wiring Distance between Inverter and Motor	100M or less	
Enclosure		IP20	
Cooling Method		Forced air cooling	
Environmental Conditions	Ambient Temperature	Open chassis -10°C ~ +50°C	
	Humidity	90%RH or less (non-condensing)	
	Storage Temperature*1	-20°C ~ +60°C	
	Location	Indoor (free from corrosive gases or dust)	
	Elevation	1000M or less	
	Vibration		Up to 9.8m/S <sup>2</sup> (1G) at 10 ~ 20Hz
			Up to 2m/S <sup>2</sup> (0.2G) at 20 ~ 50Hz

\*1 Storage Temperature during shipping (for short period).

# 1. Read first

## 1.1 Contents of the product

Explanation of the plate label.

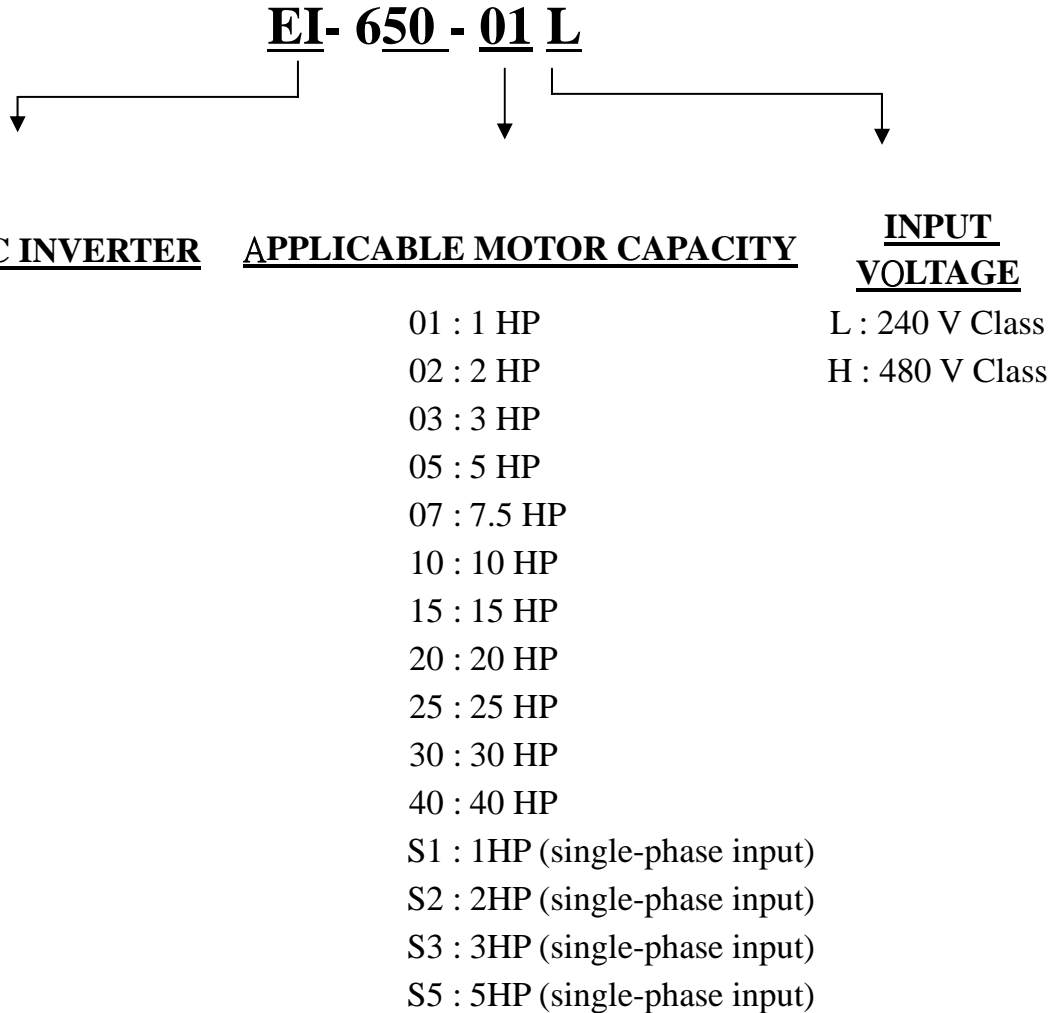

### Series Number Label

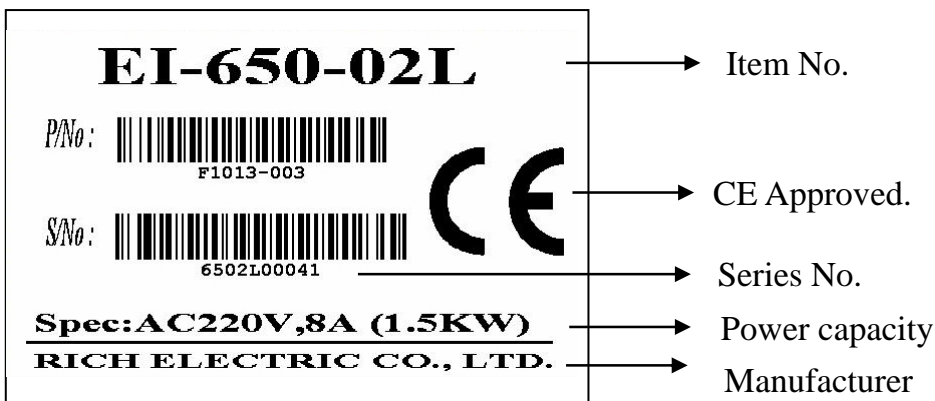

## 1.2 Names and functions

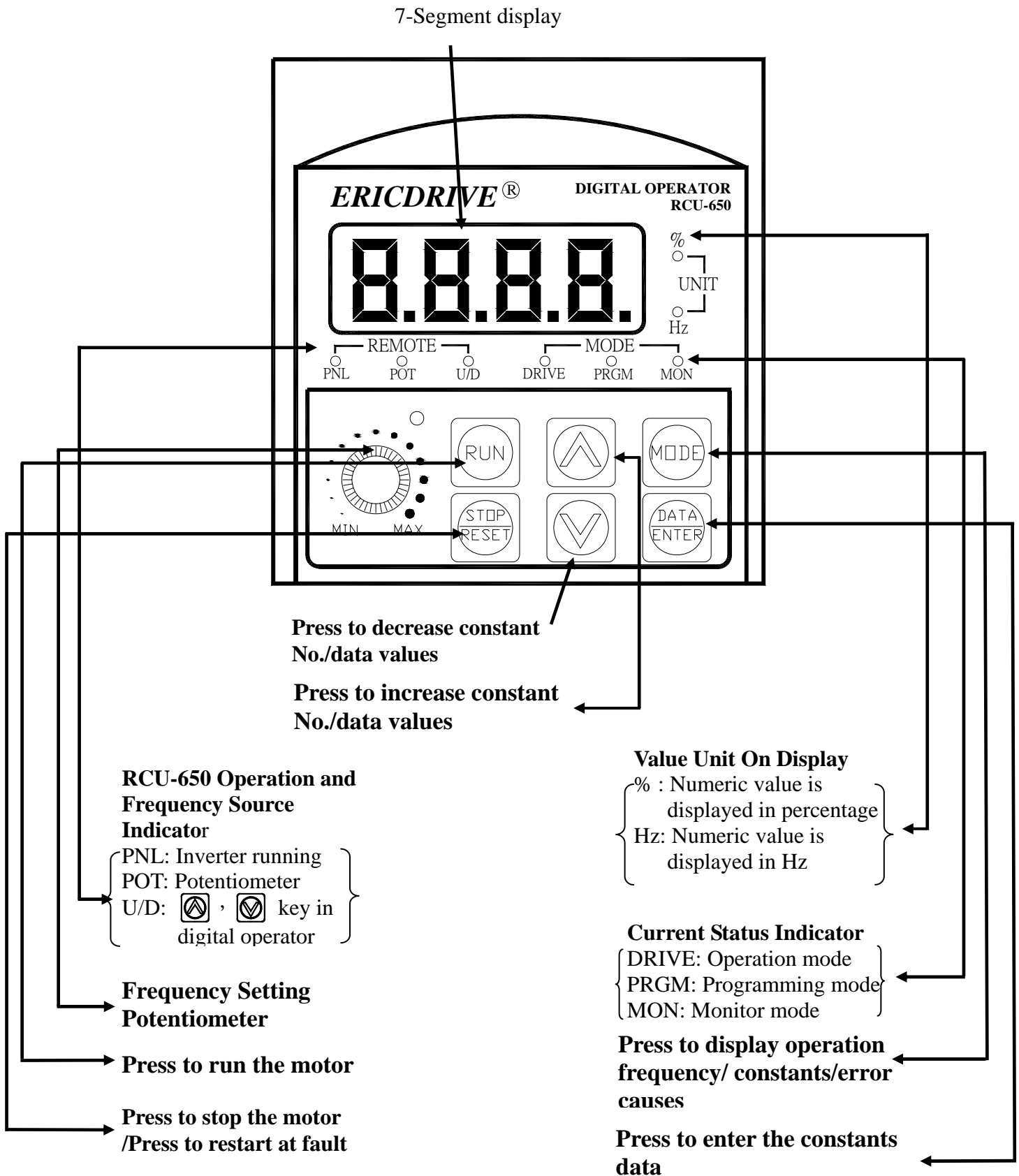

### 1.3 Power circuit and control circuit terminal boards

In case of the lug connector, cover the lug connector with insulated tube, or use the insulated lug connector.

Note 1: EMC plate is supplied as standard.

#### 1) Power circuit terminal board

In case of the lug connector, cover the lug connector with insulated tube, or use the insulated lug connector.

Screw size	tightening torque	
M3.5 screw	0.9Nm	7.1lb • in
M4 screw	1.3Nm	10.7lb • in
M5 screw	2.5Nm	22.3lb • in
M6 screw	4.5Nm	40.1lb • in

**EI – 650 - 01 L~ 05L**  
**EI – 650 - 01H~ 05H**

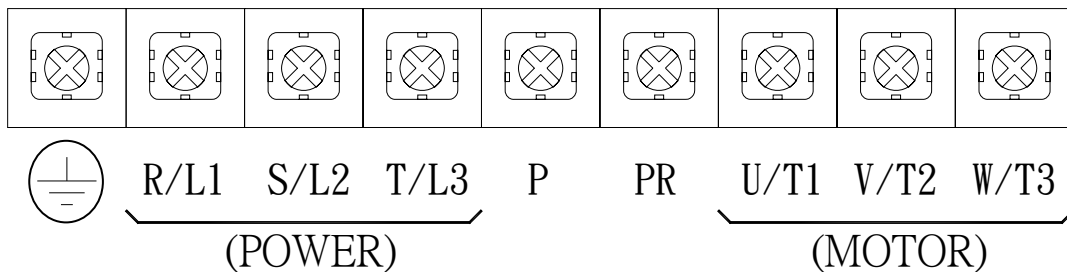

**EI – 650 - 07 L~ 10L**  
**EI – 650 - 07H ~10H**

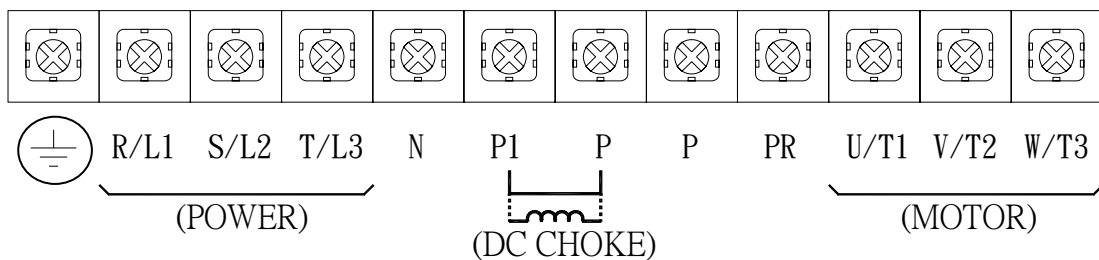

**EI – 650 - 15 L~ 40L**  
**EI – 650 - 15H ~40H**

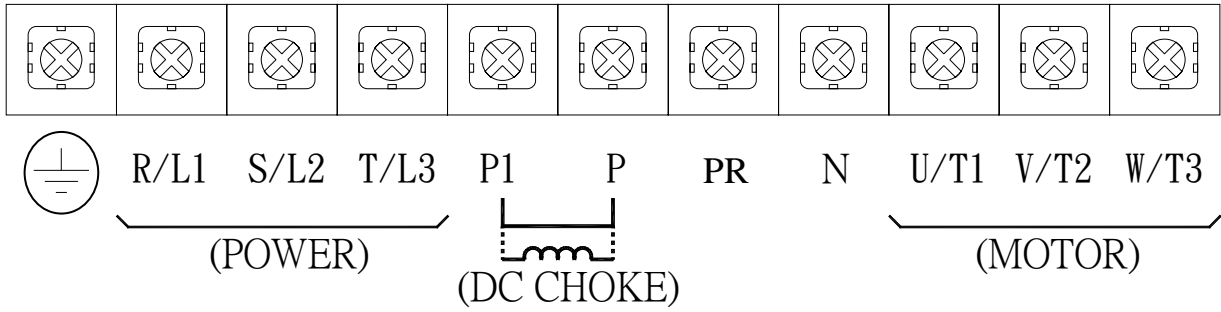

**2) Control circuit terminal board**

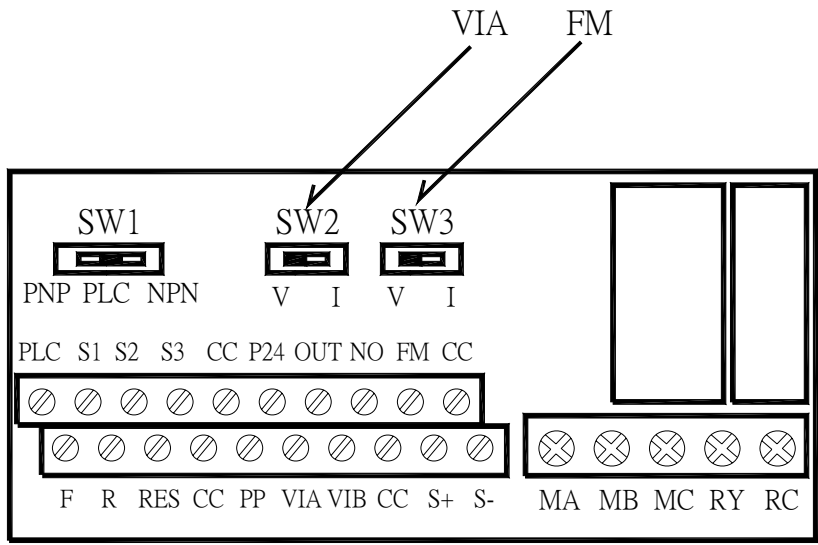

**Wire size**

Solid wire: 0.3 ~ 1.5 (mm<sup>2</sup>)  
 Stranded wire: 0.3 ~1.5 (mm<sup>2</sup>)  
 (AWG 22 ~16)  
 Sheath strip length: 6 (mm)

**Factory default settings of slide switches**

SW1: SINK (Negative) side  
 FM: V side  
 VIA: V side



**Screwdriver: Small-sized flat-blade screwdriver**

(Blade thickness: 0.4 mm or less, blade width: 2.2 mm or less)

## 1.4 Notes on the application

### 1.4.1 Motors

When the EI-650 and the motor are used in conjunction, pay attention to the following items.

 <b>Danger</b>	
 Mandatory	Use an inverter that conforms to the specifications of power supply and three-phase induction motor being used. If the inverter being used does not conform to those specifications, not only will the three-phase induction motor not rotate correctly, but it may cause serious accidents through overheating and fire.

#### Comparisons with commercial power operation.

The EI-650 Inverter employs the sinusoidal PWM system. However, the output voltage and output current are not perfect sine waves, they have a distorted wave that is close to sinusoidal waveform. This is why compared to operation with a commercial power there will be a slight increase in motor temperature, noise and vibration.

#### Operation in the low-speed area

When running continuously at low speed in conjunction with a general purpose motor, there may be a decline in that motor's cooling effect. If this happens, operate with the output decreased from rated load.

To carry out low-speed operation continuously at the rated torque, we recommend to use a inverter rated motor or a forced cooled motor designed for use with an inverter. When operating in conjunction with a inverter rated motor, you must change the inverter's motor overload protection level to VF motor use (U-17).

#### Adjusting the overload protection level

The EI-650 Inverter protects against overloads with its overload detection circuits (electronic thermal). The electronic thermal's reference current is set to the inverter's rated current, so it must be adjusted in line with the rated current of the general purpose motor being used in combination.

## High speed operation at and above 60Hz

Operating at frequencies greater than 60Hz will increase noise and vibration. There is also a possibility this will exceed the motor's mechanical strength limits and the bearing limits so you should inquire to the motor's manufacturer about such operation.

## Method of lubricating load mechanisms

Operating an oil-lubricated reduction gear and gear motor in the low-speed areas will worsen the lubricating effect. Check with the manufacturer of the reduction gear to find out about operable gearing area.

## Low loads and low inertia loads

The motor may demonstrate instability such as abnormal vibrations or overcurrent trips at light loads of 50 % or under of the load percentage, or when the load's inertia moment is extremely small. If that happens reduce the carrier frequency.

## Occurrence of instability

Unstable phenomena may occur with the load and motor combinations shown below.

- Combined with a motor that exceeds applicable motor ratings recommended for the inverter
- Combined with special motors
- For 480V class with long cable

To deal with the above lower the settings of inverter carrier frequency.

- Combined with couplings between load devices and motors with high backlash

When using the inverter in the above combination, use the S-pattern acceleration/deceleration function, or when vector control is selected, adjust the speed control response/stability factor or switch to V/f control mode.

- Combined with loads that have sharp fluctuations in rotation such as piston movements

In this case, adjust the response time (inertial moment setting) during vector control or switch to V/f control.

## Braking a motor when cutting off power supply

A motor with its power cut off goes into free-run, and does not stop immediately. To stop the motor quickly as soon as the power is cut off install an auxiliary brake. There are different kinds of brake devices, both electrical and mechanical. Select the brake that is best for the system.

## Load that produces regenerative torque

When combined with a load that produces regenerative torque, the overvoltage or overcurrent protection function may be activated to trip the inverter. For this kind of situation, you must install a dynamic braking resistor that complies with the load conditions, or increase deceleration time.

## Braking motor

When using a braking motor, if the braking circuit is directly connected to the inverter's output terminals, the brake cannot be released because of the lowered starting voltage. Therefore, when using a braking motor, connect the braking circuit to the inverter's power supply side, as shown in the figure below. Usually, braking motors produce larger noise in low speed ranges.

Note: In the case of the circuit shown on the below, assign the function of detecting low-speed signals to the RY and RC terminals. Make sure the parameter **A-30** is set to **4** (factory default setting)

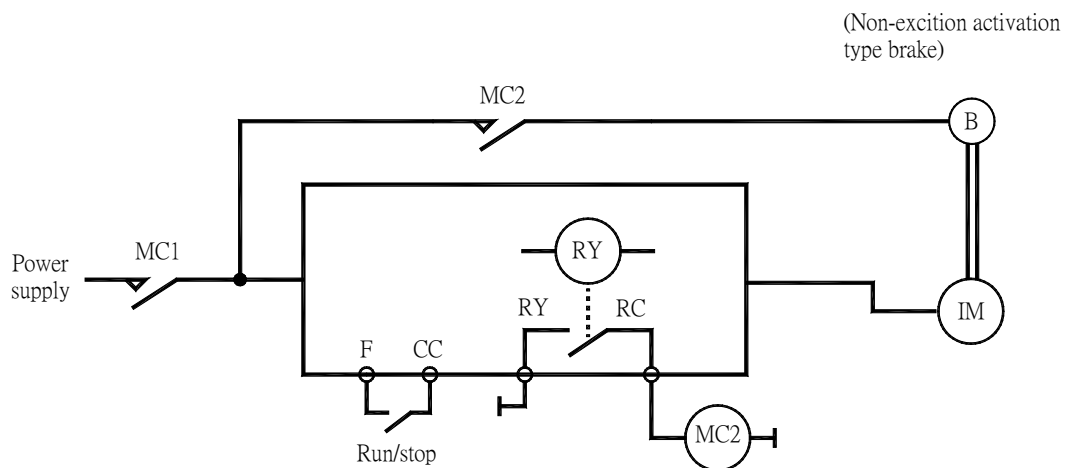

### **Measures to protect motors against surge voltages**

In a system in which a 480V-class inverter is used to control the operation of a motor, very high surge voltages may be produced. When applied to the motor coils repeatedly for a long time, may cause deterioration of their insulation, depending on the cable length, cable routing and types of cables used. Here are some examples of measures against surge voltages.

- (1) Lower the inverter's carrier frequency.
- (2) Set the parameter **U - 16** (Carrier frequency control mode selection) to **2** or **3**.
- (3) Use a motor with high insulation strength.
- (4) Insert an AC reactor or a surge voltage suppression filter between the inverter and the motor.

## 1.4.2 Inverters

### **Protecting inverters from overcurrent**

The inverter has an overcurrent protection function. The programmed current level is set to the inverter's maximum applicable motor. If the motor used has a small capacity, the overcurrent level and the electronic thermal protection must be readjusted. If adjustment is necessary, see 6.13, and make adjustments as directed.

### **Inverter capacity**

Do not use a small-capacity (kVA) inverter to control the operation of a large-capacity motor (two-class or more larger motor), no matter how light the load is. Current ripple will raise the output peak current making it easier to set off the overcurrent trip.

### **Power factor correction capacitor**

Power factor correction capacitors cannot be installed on the output side of the inverter. When a motor is run that has a power factor correction capacitor attached to it, remove the capacitors. This can cause inverter malfunction trips and capacitor destruction.

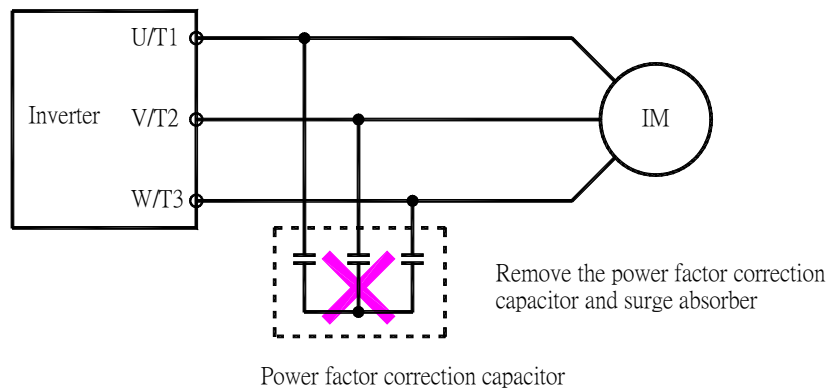

### Operating at other than rated voltage

Connections to voltages other than the rated voltage described in the rating label cannot be made. If a connection must be made to a power supply other than one with rated voltage, use a transformer to raise or lower the voltage to the rated voltage.

### Circuit breaking when two or more inverters are used on the same power line.

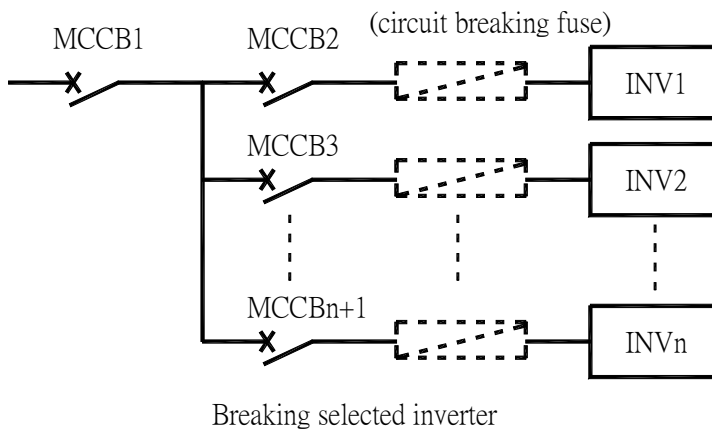

There is no fuse in the inverter's main circuit. Thus, as the diagram above shows, when more than one inverter is used on the same power line, you must select interrupting characteristics so that only the MCCB2 will trip and the MCCB1 will not trip when a short occurs in the inverter (INV1). When you cannot select the proper characteristics install a circuit interrupting fuse between the MCCB2 and the INV1.

### If power supply distortion is not negligible

If the power supply distortion is not negligible because the inverter shares a power distribution line with other systems causing distorted waves, such as systems with thyristors or large-capacity inverters, install an input reactor to improve the input power factor, to reduce higher harmonics, or to suppress external surges.

### ■ Disposal

If an inverter is no longer usable, dispose of it as industrial waste.

### 1.4.3 What to do about the leak current



#### Warning

Current may leak through the inverter's input/output wires because of insufficient electrostatic capacity on the motor with bad effects on peripheral equipment. The leakage current's value is affected by the carrier frequency and the length of the input/output wires. Test and adopt the following remedies against leak current.

#### (1) Effects of leak current across ground

Leakage current may flow not just through the inverter system but also through ground wires to other systems. Leakage current will cause earth leakage breakers, leakage current relays, ground relays, fire alarms and sensors to operate improperly, and it will cause superimposed noise on the CRT screen or display of incorrect current detection with the CT.

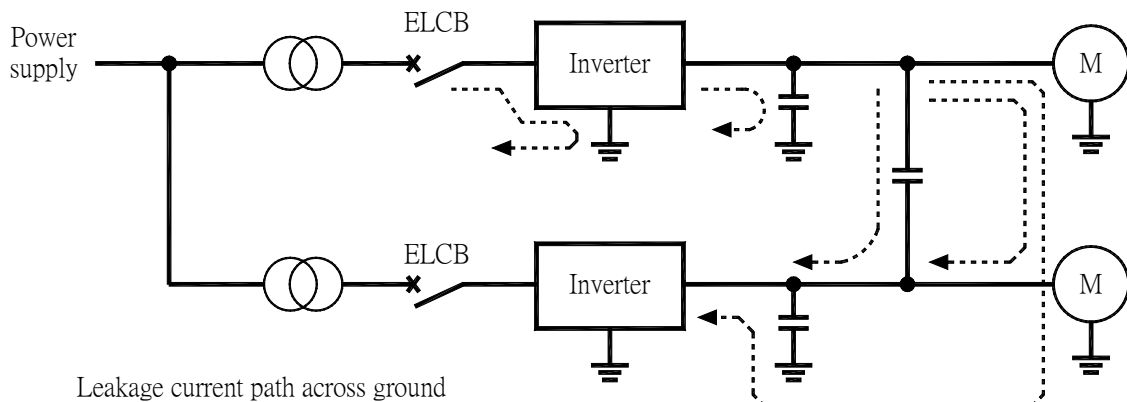

### Remedies:

1.If there is no radio-frequency interference or similar problem, detach the built-in noise filter capacitor, using the grounding capacitor disconnecting switch or tap. (Only EI-650-15H(L)~EI-650-40H(L))

2.Reduce PWM carrier frequency.

The setting of PWM carrier frequency is done with the parameter **C-00**  
Although the electromagnetic noise level is reduced, the motor acoustic noise is increased.

3. Use high frequency remedial products for earth leakage breakers.

## (2) Affects of leakage current across lines

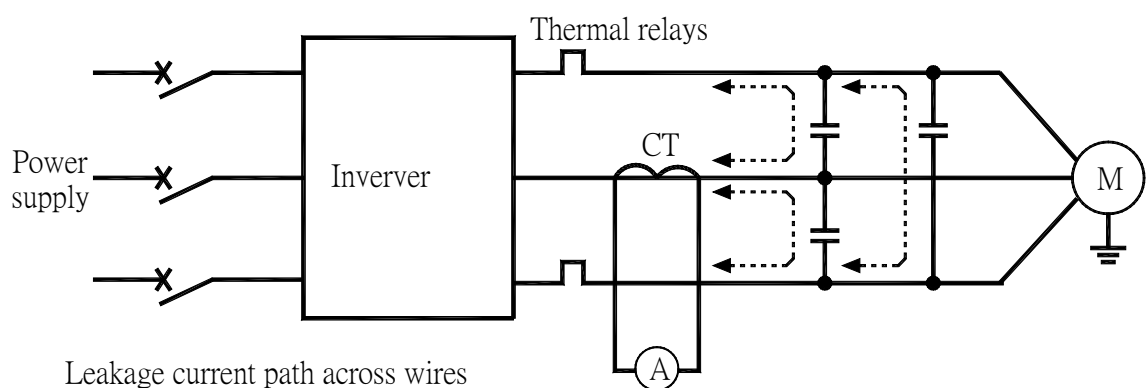

### (1) Thermal relays

The high frequency component of current leaking into electrostatic capacity between inverter out- put wires will increase the effective current values and make externally connected thermal relays operate improperly. If the wires are more than 50 meters long, it will be easy for the external thermal relay to operate improperly with models having motors of low rated current (several A(ampere) or less), especially the 480V class low capacity (5HP or less) models, because the leak current will increase in proportion to the motor rating.

## Remedies:

1. Use the electronic thermal built into the inverter. (See 6.13)

The setting of the electronic thermal is done using parameter **U-16** , **U-17** .

2. Reduce the inverter's PWM carrier frequency. However, that will increase the motor's magnetic noise.

The setting of PWM carrier frequency is done with the parameter **C-00**.  
(See 7.12, Page 7-32)

3. This can be improved by installing 0.1 $\mu$ ~0.5 $\mu$ F - 1000V film capacitor to the input/output terminals of each phase in the thermal relay.

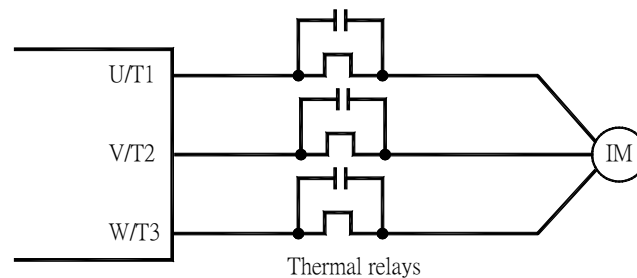

- (2) CT and ammeter

If a CT and ammeter are connected externally to detect inverter output current, the leak current's high frequency component may destroy the ammeter. If the wires are more than 50 meters long, it will be easy for the high frequency component to pass through the externally connected CT and be superimposed on and burn the ammeter with models having motors of low rated current (several A(ampere) or less), especially the 480V class low capacity (5HP or less) models, because the leak current will increase in proportion to the motor's rated current.

## Remedies:

### 1. Use a meter output terminal in the inverter control circuit

The load current can be output on the meter output terminal (FM). If the meter is connected, use an ammeter of 1mA<sub>dc</sub> full scale or a voltmeter of 7.5V-1mA full scale.

0-20mA<sub>dc</sub> (4-20mA<sub>dc</sub>) can be also output. (See 6.5, Page 6-11)

### 2. Use the monitor functions built into the inverter.

Use the monitor functions on the panel built into the inverter to check current values. (See 8.1.1, Page 8-1)

## 1.4.4 Installation

### ■ Installation environment

The EI-650 Inverter is an electronic control instrument. Take full consideration to installing it in the proper operating environment.

- Operate in areas where ambient temperature ranges from -10°C to 50°C.

Operation over 40°C is allowed when the top label is peeled off. When installing the inverter where the ambient temperature will rise above 50°C, remove the label (seal) from the top and operate it at a current lower than the rated one.

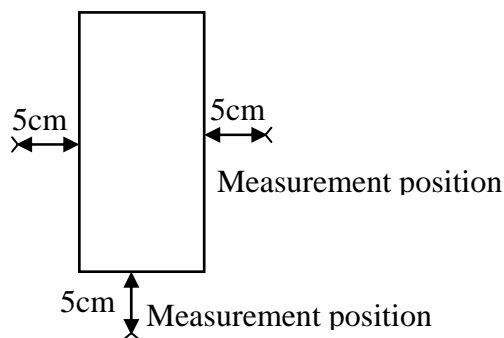

Note: The inverter is a heat-emitting body. Make sure proper space and ventilation is provided when installing in the cabinet. When installing inside a cabinet, we recommend the top seal peeled off although 40°C or less.

- Do not install in any location that is subject to large amounts of vibration.

Note: If the EI-650 Inverter is installed in a location that is subject to vibration, anti-vibration measures are required. Please consult with RICH about these measures.

- If the EI-650 inverter is installed near any of the equipment listed below, provide measures to insure against errors in operation.

Solenoids:	Attach surge suppressor on coil.
Brakes:	Attach surge suppressor on coil.
Magnetic contactors:	Attach surge suppressor on coil.
Fluorescent lights:	Attach surge suppressor on coil.
Resistors:	Place far away from EI-650 Inverter.

#### ■ Environmental Conditions

- Verify the ambient condition for the mounting location.
  - Ambient temperature should not be below  $-10^{\circ}\text{C}$  or exceed  $50^{\circ}\text{C}$ .
  - Relative humidity should be less than 90% (non-condensing).
  - Altitude should be below 3,300ft (1,000m).
- Do not mount the inverter in direct sunlight and isolate it from excessive vibration.

#### ■ Mounting

- The inverter must be mounted vertically with sufficient horizontal and vertical space between adjacent equipment (A= Over 6" (150mm), B= Over 2" (50mm)).

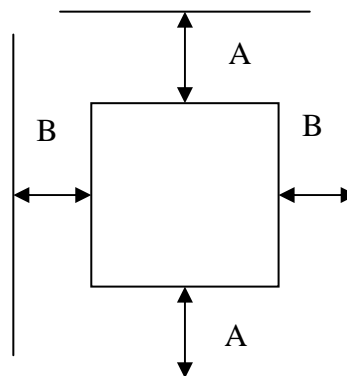

## ■ Other Precautions

- Do not carry the inverter by the front cover.
- Do not install the inverter in a location where excessive vibration is present. Be cautious when installing on presses or moving equipment.
- The life span of the inverter is greatly affected by the ambient temperature. Install in a location where temperature are within permissible limits (-10 ~ +50°C).
- The inverter operates at high-temperatures - install on a non-combustible surface.
- Do not install the inverter in high-temperature or high-humidity locations.
- Do not install the inverter in a location where oil mist, combustible gas, or dust is present. Install the inverter in a clean location or in an enclosed panel, free of foreign substance.
- When installing the inverter inside a panel with multiple inverters or a ventilating fan, use caution.

If installed incorrectly, the ambient temperature may exceed specified limits.

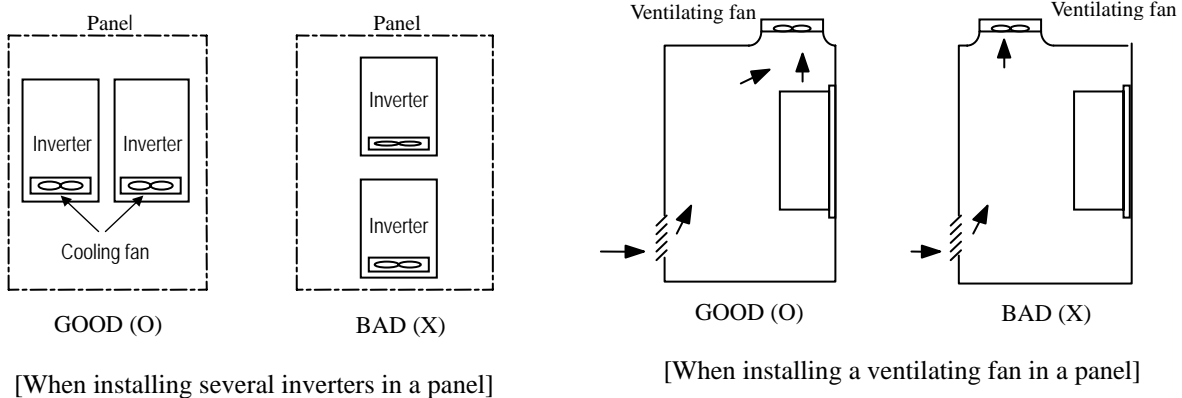

- Install the inverter using screws or bolts to insure the inverter is firmly fastened.

## 1.5 Dimension

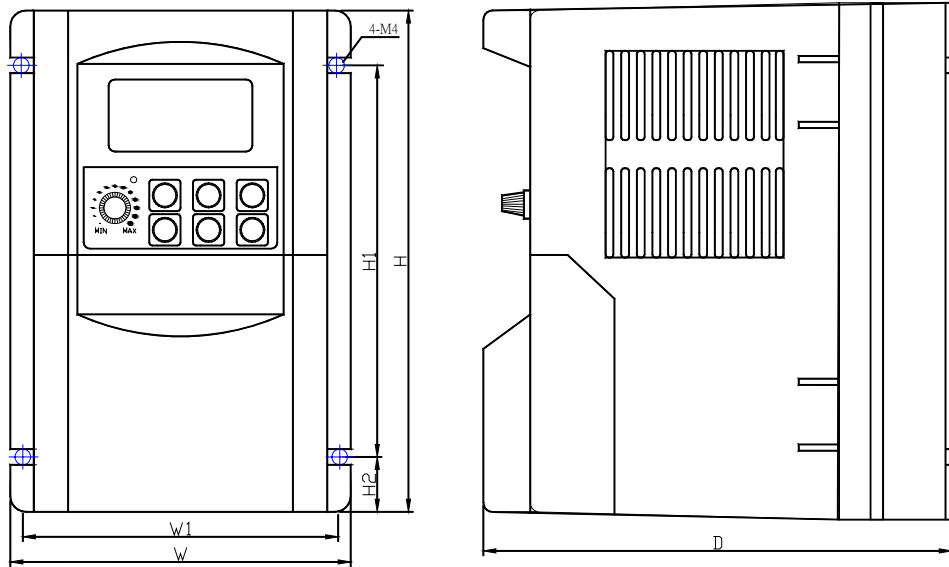

Fig.1

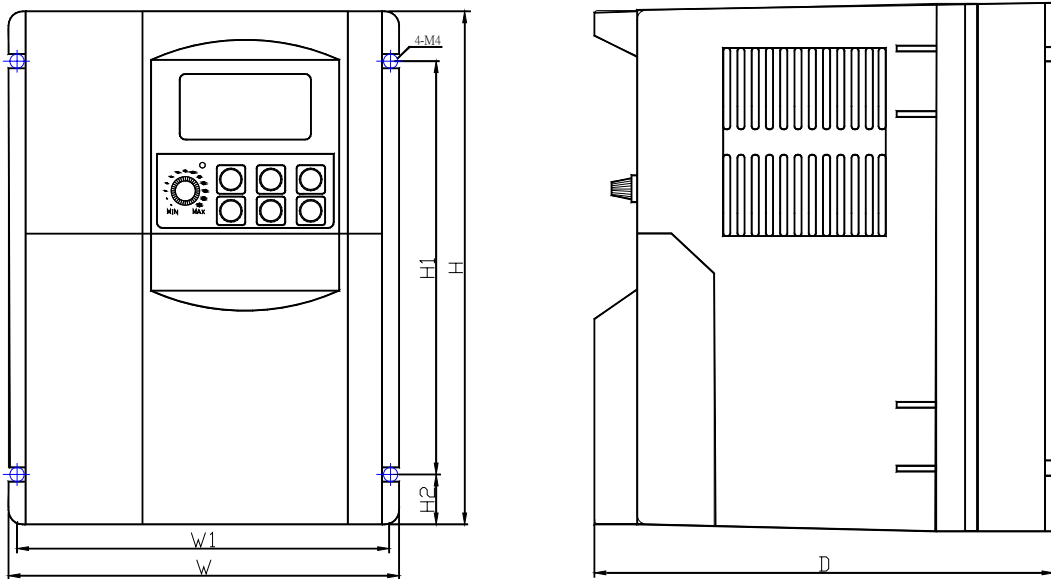

Fig.2

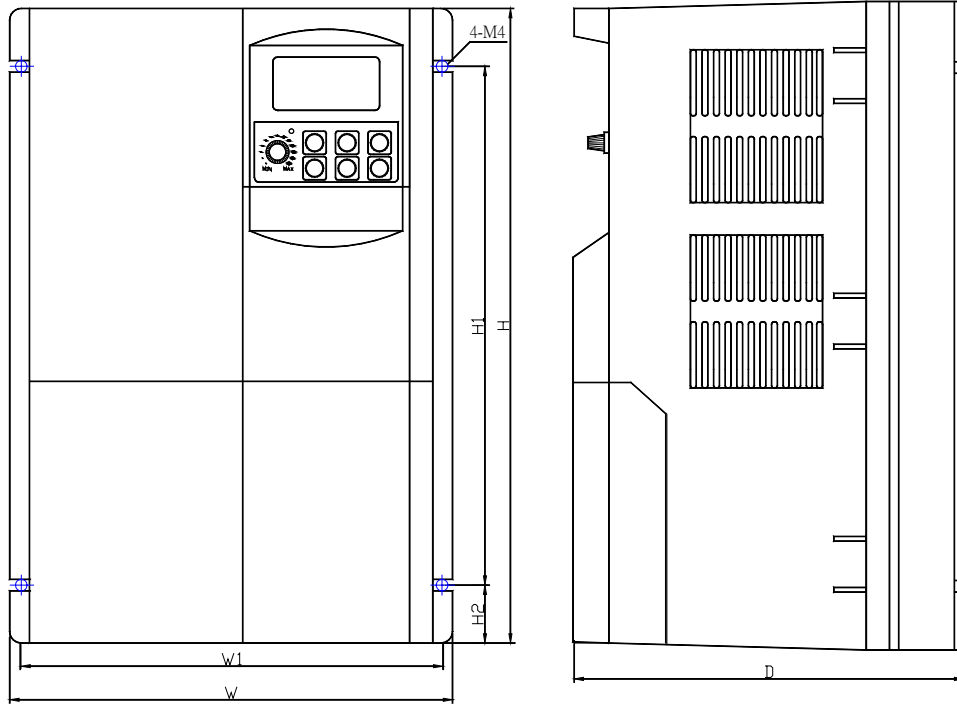

Fig.3

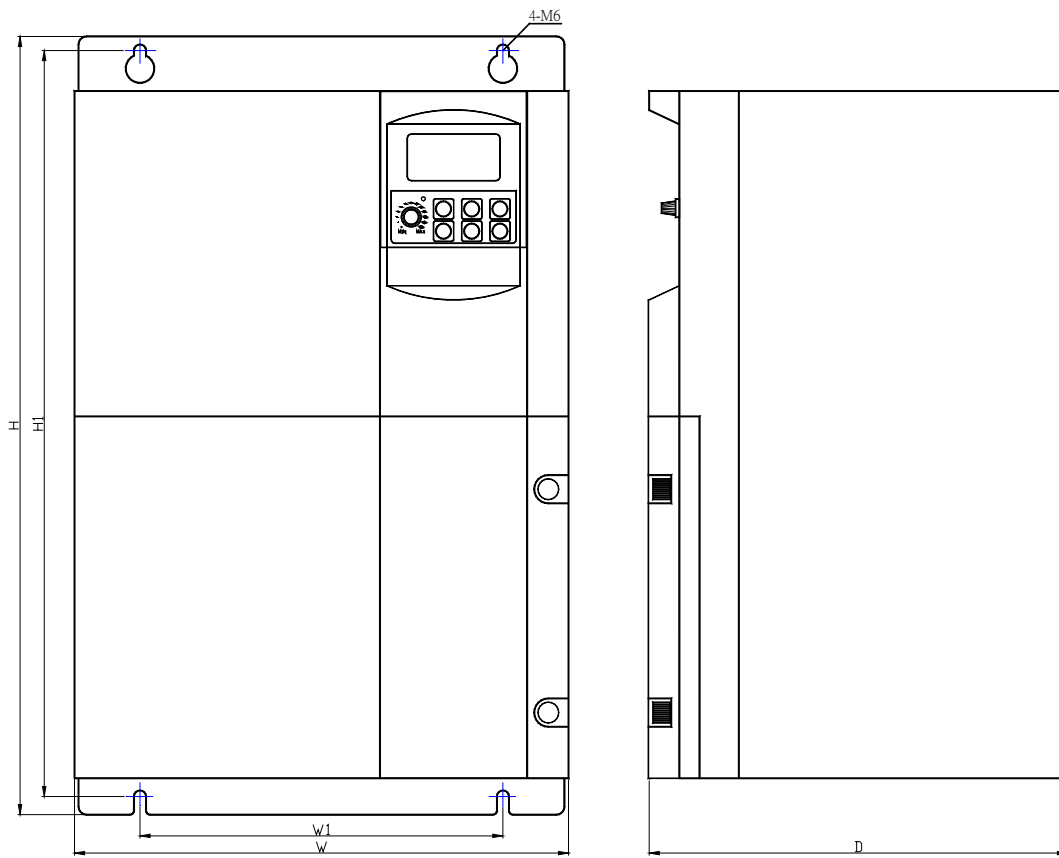

Fig.4

Dimensions in mm/Mass in kg

<b>Voltage Class</b>	<b>Capacity (HP)</b>	<b>W</b>	<b>H</b>	<b>D</b>	<b>W1</b>	<b>H1</b>	<b>H2</b>	<b>Mass</b>	<b>Fig.</b>
220V Single phase	1HP	109	165	150	100	125	20	1.4	1
	2HP								
	3HP	137	185	161	128	145	20	2.0	2
	5HP								
220V 3-phase	1HP	109	165	150	100	125	20	1.4	1
	2HP								
	3HP	137	185	161	128	145	20	2.0	2
	5HP								
	7.5HP	191	280	168	181	224	28	5.3	3
	10HP								
	15HP	245	385	197.5	180	369	X		4
	20HP								
	25HP	300	460	197.5	235	444	X		4
	30HP								
	40HP								
440V 3-phase	1HP	109	165	150	100	125	20	1.4	1
	2HP								
	3HP	137	185	161	128	145	20	2.0	2
	5HP								
	7.5HP	191	280	168	181	224	28	5.3	3
	10HP								
	15HP	245	385	197.5	180	369	X		4
	20HP								
	25HP	300	460	197.5	235	444	X		4
	30HP								
	40HP								

## 2. Connection

### 2.1 Standard connection

#### 2.1.1 Standard connection diagram 1

This diagram shows a standard wiring of the main circuit.

Standard connection diagram – SINK (Negative) (Common: CC)

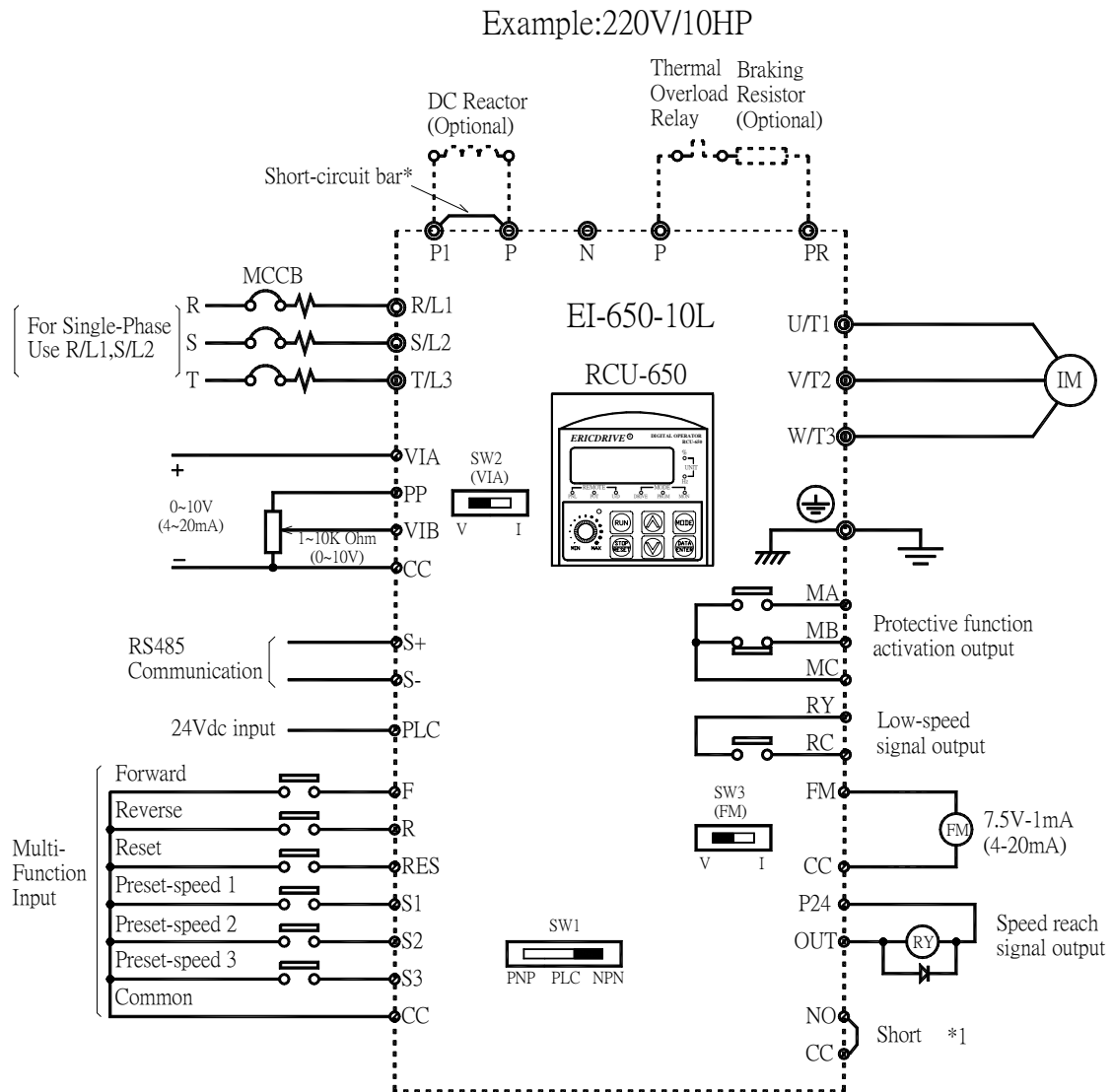

## 2.1.2 Standard connection diagram 2

### Standard connection diagram – SOURCE (Positive) (Common: P24)

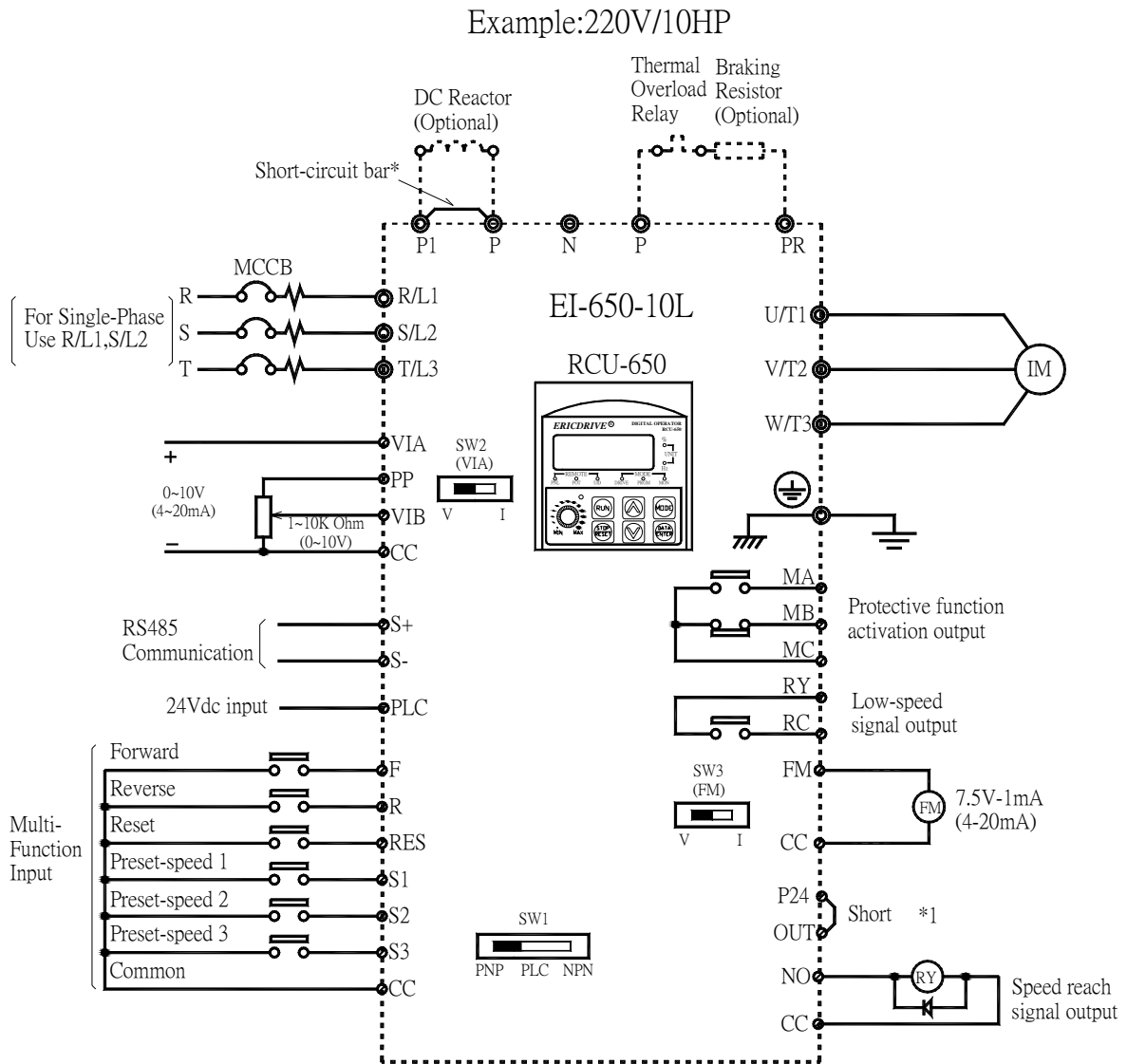

## 2.2 Description of terminals

### 2.2.1 Power circuit terminals

This diagram shows an example of wiring of the main circuit. Use options if necessary.

#### ■ Power supply and motor connections

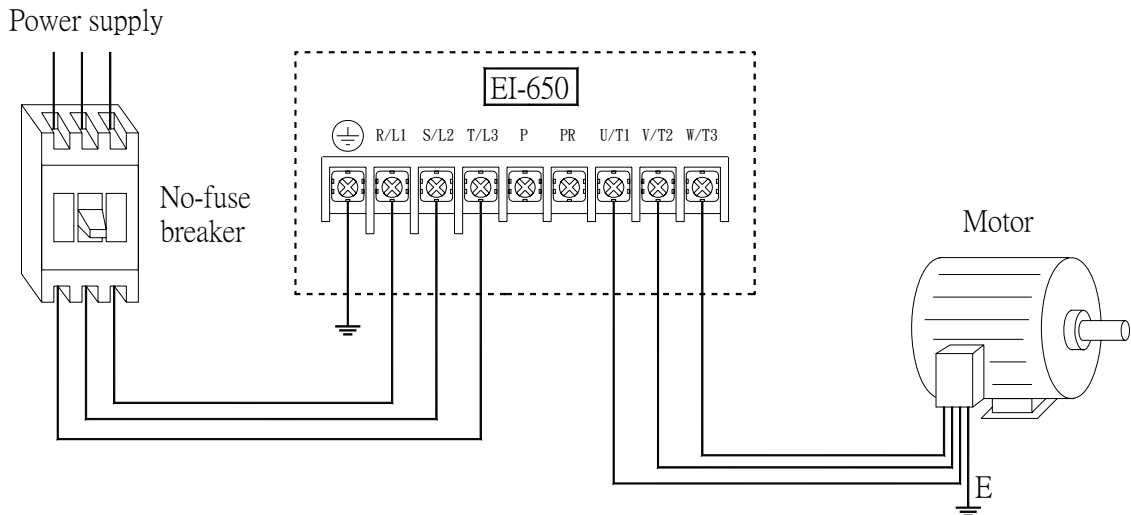

#### ■ Connections with peripheral equipment

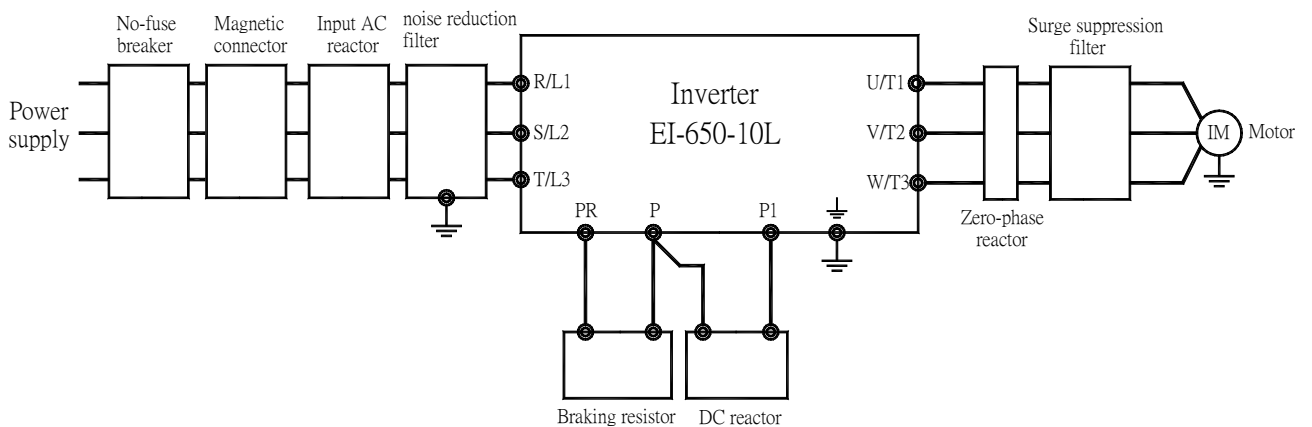

Note 1: The T/L3 terminal is not provided for any single-phase 240V model. So if you are using a single-phase 240V model, use the R/L1 and S/L2 terminals to connect power cables.

## ■ Power circuit

Terminal symbol	Terminal function
$\perp$	Grounding terminal for connecting inverter.
R/L1, S/L2, T/L3	240V class: single-phase 200 to 240V-50/60Hz three-phase 200 to 240V-50/60Hz 480V class: three-phase 380 to 480V-50/60Hz * Single-phase input: R/L1 and S/L2 terminals
U/T1, V/T2, W/T3	Connect to a (three-phase induction) motor.
P, PR	Connect to braking resistors. Change parameters <b>C-04, C-05, C-08, C-09</b> if necessary.
N	This is a negative potential terminal in the internal DC main circuit. DC common power can be input across the P terminals (positive potential).
P1, P	Terminals for connecting a DC reactor (DCL: optional external device). Shorted by a short bar when shipped from the factory. Before installing DCL, remove the short bar.

The arrangement of power circuit terminals are different from each range.

### 2.2.2 Control circuit terminals

The control circuit terminal board is common to all equipment.

Regarding to the function and specification of each terminals, please refer to the following table.

■ Control circuit terminals

Terminal symbol	Input / Output	Function	Electrical specifications	Inverter internal circuits
F	Input	Multifunction programmable contact input	No voltage contact input 24Vdc-5mA or less  <u>*NPN/PLC</u> <u>selectable using SW1</u>	
R	Input			
RES	Input			
S1	Input			
S2	Input			
S3	Input			
PLC	Input (common)			
CC	Common to Input/output	Control circuit's equipotential terminal (4 terminals)		
PP	Output	Analog power supply output	10Vdc (permissible load current: 10mA)	

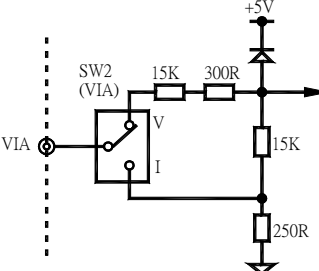
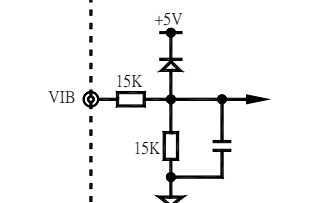
Terminal symbol	Input / Output	Function	Electrical specifications	Inverter internal circuits
VIA	Input	<p>Multifunction programmable analog input. Factory default setting: 0~10Vdc and 0~60Hz (0~50Hz) frequency input. The function can be changed to 4~20mA (0~20mA) current input by flipping the VIA slide switch SW2 to the I position.</p> <p>By changing parameter setting, this terminal can also be used as a multifunction programmable contact input terminal. When using the sink logic slide SW1 to NPN position be sure to insert a resistor between P24-VIA (4.7 kΩ-1/2 W). Also move the VIA dip switch to the V position.</p>	<p>10Vdc (internal impedance: 30kΩ)</p> <p>4-20mA (internal impedance: 250Ω)</p>	
VIB	Input	<p>Multifunction programmable analog input. Standard default setting: 0~10Vdc input and 0~60Hz (0~50Hz) frequency</p> <p>By changing parameter setting, this terminal can also be used as a multifunction programmable contact input terminal. When using the sink logic slide SW1 to NPN position be sure to insert a resistor between P24 and VIB. (4.7 kΩ-1/2 W)</p>	<p>10Vdc (internal impedance: 30kΩ)</p>	

Terminal symbol	Input / Output	Function	Electrical specifications	Inverter internal circuits
FM	Output	<p>Multifunction programmable analog output. Standard default setting: output frequency.</p> <p>The function can be changed to 0-20mA (4-20mA) current output by flipping the FM slide switch SW3 to the I position.</p>	<p>1mA<sub>dc</sub> full-scale ammeter or 7.5V<sub>dc</sub> (10V<sub>dc</sub>)1mA full-scale voltmeter</p> <p>0-20mA (4-20mA) DC ammeter</p> <p>Permissible load resistance: 750Ω or less</p>	
P24	Output	24V <sub>dc</sub> power output	24V <sub>dc</sub> -100mA	
OUT NO	Output	<p>Multifunction programmable open collector output. Standard default settings detect and output speed reach signal output frequencies.</p> <p>Multifunction output terminals to which two different functions can be assigned.</p> <p>The NO terminal is an isoelectric output terminal. It is insulated from the CC terminal.</p> <p>By changing parameter settings, these terminals can also be used as multifunction programmable pulse train output terminals.</p>	<p>Open collector output 24V<sub>dc</sub>-50mA</p> <p>To output pulse trains, a current of 10mA or more needs to be passed.</p> <p>Pulse frequency range: 38~1600Hz</p>	

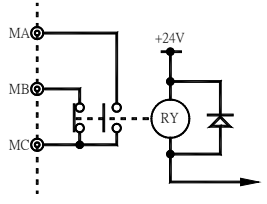
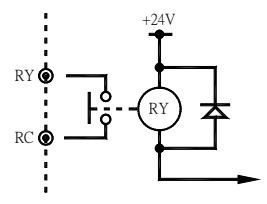
Terminal symbol	Input / Output	Function	Electrical specifications	Inverter internal circuits
FLA FLB FLC	Output	Multifunction programmable relay contact output. Detects the operation of the inverter's protection function. Contact across FLA-FLC is closed and FLB- FLC is opened during protection function operation.	250Vac-1A ( $\cos \varphi = 1$ ) : at resistance load 30Vdc-0.5A 250Vac-0.5A ( $\cos \varphi = 0.4$ )	
RY RC	Output	Multifunction programmable relay contact output. Standard default settings detect and output low-speed signal output frequencies. Multifunction output terminals to which two different functions can be assigned.	250Vac-1A ( $\cos \varphi = 1$ ) : at resistance load 30Vdc-0.5A 250Vac-0.5A ( $\cos \varphi = 0.4$ )	
S+ S-	Communications Output	MODBUS communication run through RS-485. MODBUS protocol.		

\* PTC (Positive Temperature Coefficient) : Resettable thermal fuse resistor for over current protection

- SINK (Negative) logic Slide SW1 to NPN position / SOURCE (Positive) logic Slide SW to NPN position (When the inverter's internal power supply is used)

Current flowing out turns control input terminals on. These are called sink logic terminals. The general used method in Europe is source logic in which current flowing into the input terminal turns it on.

Sink logic is sometimes referred to as negative logic, and source logic is referred to as positive logic. Each logic is supplied with electricity from either the inverter's internal power supply or an external power supply, and its connections vary depending on the power supply used.

<Examples of connections when the inverter's internal power supply is used>

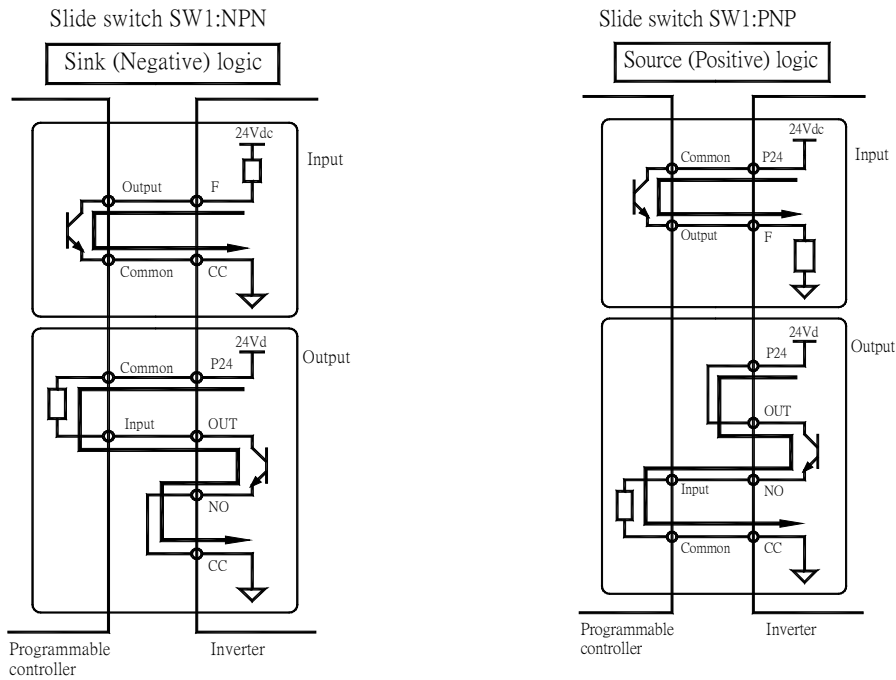

■ SINK (Negative) logic/SOURCE (Positive) logic (When an external power supply is used)

The PLC terminal is used to connect to an external power supply or to insulate a terminal from other input or output terminals. As for input terminals, turn the SW1 slide switch to the PLC position.

<Examples of connections when an external power supply is used>

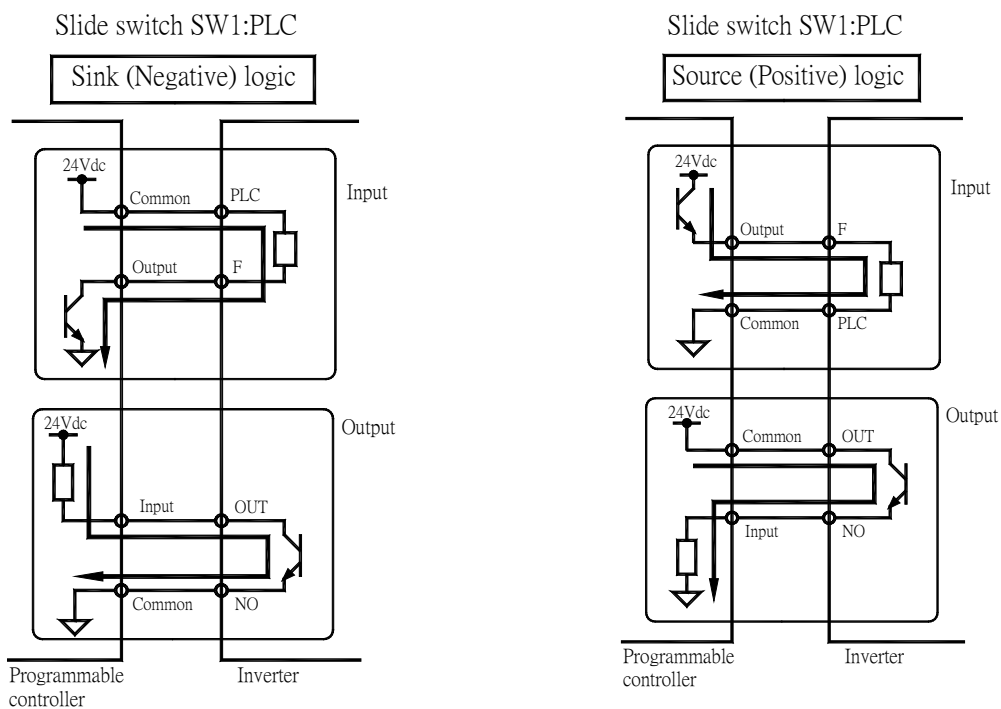

## ■ Selecting the functions of the VIA and VIB terminals between analog input and contact input

The functions of the VIA and VIB terminals can be selected between analog input and contact input by changing parameter settings (**A-09**). (Factory default setting: Analog input)

When using these terminals as contact input terminals in a sink logic circuit, be sure to insert a resistor between the P24 and VIA terminals or between the P24 and VIB terminals. (Recommended resistance:  $4.7\text{K}\Omega$ -1/2W)

When using the VIA terminal as a contact input terminal, be sure to turn the VIA switch to the V position. If no resistor is inserted or the VIA slide switch is not turned to the V position, contact input will be left always ON, which is very dangerous.

Switch between analog input and contact input before connecting the terminals to the control circuit terminals. Otherwise the inverter or devices connected to it may be damaged.

☆ The figure on the right shows an example of the connection of input terminals VIA and VIB when they are used as contact input terminals. This example illustrates the connection when the inverter is used in sink (Negative) logic mode.

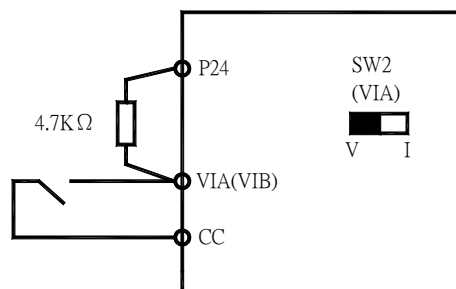

## ■ Logic switching/Voltage-current output switching (slide switch)

### (1) Logic switching

Use SW1 to switch between logics.

Switch between logics before wiring to the inverter and without supplying power. If switching between NPN, PNP and PLC is done when power is turned on after switching or when the inverter is supplied with power, the inverter might become damaged. Confirm it before supplying power.

### (2) Voltage-current output switching

Use the FM switch SW3 to switch between voltage output and current output. Switch the FM terminal's voltage-current output before wiring to inverter or without supplying power

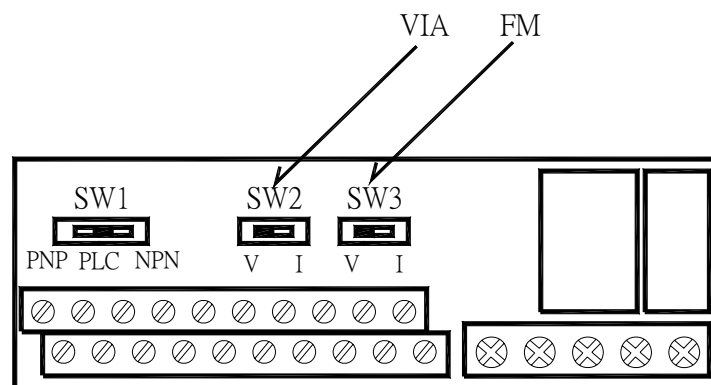

Factory default settings of slide switches

SW1: SINK (Negative) side

SW2 (FM): V side

SW3 (VIA):V side

### 3. Operations

#### 3.1 Simplified Operation of the EI-650

The procedures for setting operation frequency and the methods of operation can be selected from the following.

Start / Stop

- : (1) Start and stop using the operation panel keys
- (2) Run and stop from the operation panel

Setting the frequency

- : (1) Setting using the potentiometer on the inverter main unit
- (2) Setting using the operation panel
- (3) Setting using external signals to the terminal board (0-10Vdc, 4-20mAdc)













Use the basic parameters **U-01** (Operation command mode selection), **U-02** (Speed setting mode selection).

Title	Function	Adjustment range	Default setting
<b>U-01</b>	Command mode selection	0: Terminal board 1: Panel	1
<b>U-02</b>	Frequency setting mode	0: Internal potentiometer setting 1: VIA 2: VIB 3: Operation panel 4: Serial communication 5: External contact UP/DOWN 6: VIA+VIB (Override)	0



\* See 6.4 for **U-02=4,5** and **6**



### 3.1.1 How to start and stop

[Example of a **U-01** Setting procedure]

Key operated	LED display	Operation
	<b>00</b>	Displays the operation frequency. (operation stopped). (When standard monitor display selection <b>H-10=0</b> [Operation frequency])
	<b>CU-H</b>	Displays the first basic parameter [History ( <b>CU-H</b> )]
 	<b>U-01</b>	Press either the  key or  key to select “ <b>U-01</b> ”.
	<b>1</b>	Press  key to display the parameter setting. (Default setting: <b>1</b> ).
 	<b>0</b>	Change the parameter to <b>0</b> (terminal board) by pressing the  key .
	<b>0 ⇔ U-01</b>	Press the  key to save the changed parameter. <b>U-01</b> and the parameter set value are displayed alternately.

#### (1) Start and stop using the operation panel keys ( **U-01=1** )

Use the  and  keys on the operation panel to start and stop the motor.

 : Motor starts.       : Motor stops.

☆ To switch between forward run and reverse run from the control panel, the parameter **U-06** (forward/reverse run selection) needs to be set to **2** or **3**.

#### (2) RUN/STOP by means of an external signal to the terminal board ( **U-01=0** ): Sink (Negative ) logic

Use external signals to the inverter terminal board to start and stop the motor.

Short **F** and **CC** terminals: run forward

Open **F** and **CC** terminals: slow down and stop

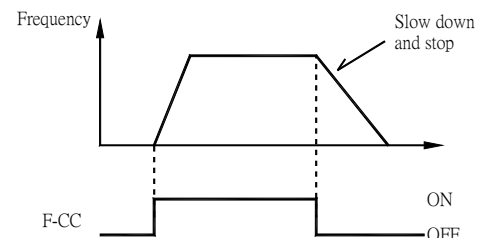

### (3) Coast stop

The standard default setting is for slowdown stop.  
 To make a coast stop, assign a “1(ST)” terminal function to an idle terminal using the programmable terminal function.  
 hanger to **R- 10 = 0**.

For coast stop, open the ST-CC when stopping the motor in the state described at left. The monitor on the inverter at this time will display **OFF**

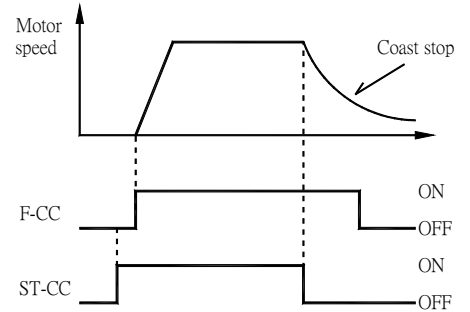

### 3.1.2 How to set the frequency

[Example of a **U-02** Setting procedure]

Key operated	LED display	Operation
	<b>00</b>	Displays the operation frequency. (operation stopped). (When standard monitor display selection <b>H- 10 = 0</b> [Operation frequency])
	<b>CU-H</b>	Displays the first basic parameter [History ( <b>CU-H</b> )].
	<b>U-02</b>	Press either the  key or  key to select “ <b>U-02</b> ”.
	<b>0</b>	Press the  key to display the parameter setting. (Default setting: <b>0</b> ).
	<b>3</b>	Change the parameter to <b>3</b> (Operation panel) by pressing the  key .
	<b>3 ⇄ U-02</b>	Press the  key to save the changed parameter. <b>U-02</b> and the parameter set value are displayed alternately.

\* Pressing the key twice returns the display to standard monitor mode (displaying operation frequency).

#### (1) Setting the frequency using the potentiometer on the inverter main unit (**U-02 = 0**)

Set the frequency with the notches on the potentiometer.

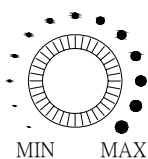

Move clockwise for the higher frequencies.

The potentiometer has hysteresis. So the set value may slightly change when the inverter is turned off, and then turned back on.

### (2) Setting the frequency using the operation panel ( U-02=3 )

Set the frequency with the operation panel.



: Moves the frequency up



: Moves the frequency down

#### ■ Example of operating a run from the panel

Key operated	LED display	Operation
	00	Displays the operation frequency. (When standard monitor display selection H-10=0 [Operation frequency])
	500	Set the operation frequency.
	500 = FC	Press the  key to save the operation frequency. FC and the frequency are displayed alternately.
	600	Pressing the  key or the  key will change the operation frequency even during operation.

### (3) Setting the frequency using the operation panel ( U-02=1 or 2 )

#### ■ Frequency setting

##### 1) Setting the frequency using external potentiometer

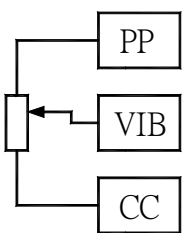

:Setting frequency using potentiometer

\* The input terminal VIA can be used in the same way.

U-02=1: VIA effective, U-02=2: VIB effective

For more details, see 7.5 (Page 7-17).

#### ★ Potentiometer

Setting frequency using the potentiometer ( 1-10kΩ, 1/4W )

For more detailed information on adjustments, see 7.5 (Page 7-17).

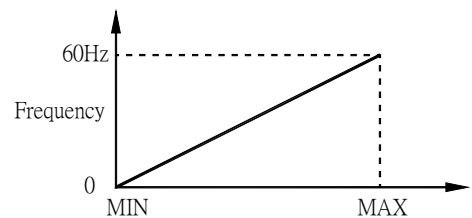

## 2) Setting the frequency using input voltage (0~10V)

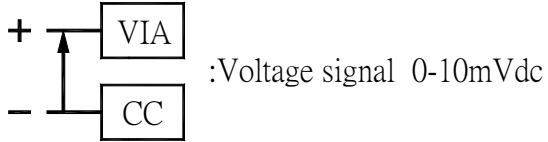

- ★ Voltage signal  
Setting frequency using voltage signals (0~10V).  
For more detailed information on adjustments, see 7.5 (Page 7-17).

\* The input terminal VIA can be used in the same way.  
~~U-02=1~~: VIA effective, ~~U-02=2~~: VIB effective  
 For more details, see 7.5 (Page 7-17).

Note: Be sure to turn the VIA slide switch SW2 to the V (Voltage) position.

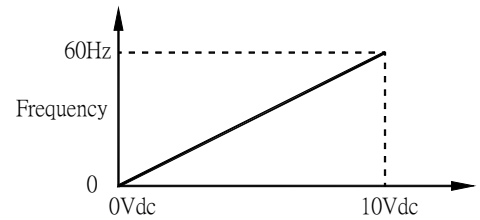

## 3) Setting the frequency using current input (4~20mA)

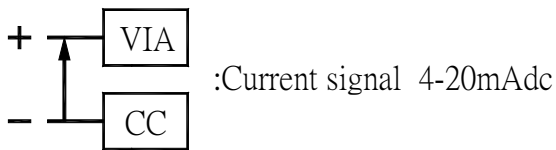

- ★ Current signal  
Current signal Setting frequency using current signals (4~20mA).  
For more detailed information on adjustments, see 7.5 (Page 7-17).

\* Setting of parameters also allow 0-20mAdc.  
 Note: Be sure to turn the VIA slide switch SW2 to the I (current) position.

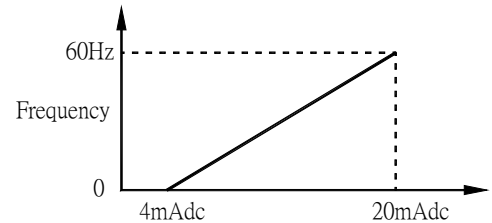

## 3.2 How to operate the EI-650

Overview of how to operate the inverter with simple examples.

Ex.1 Setting the operation frequency using built-in potentiometer and running and stopping using the operation panel.

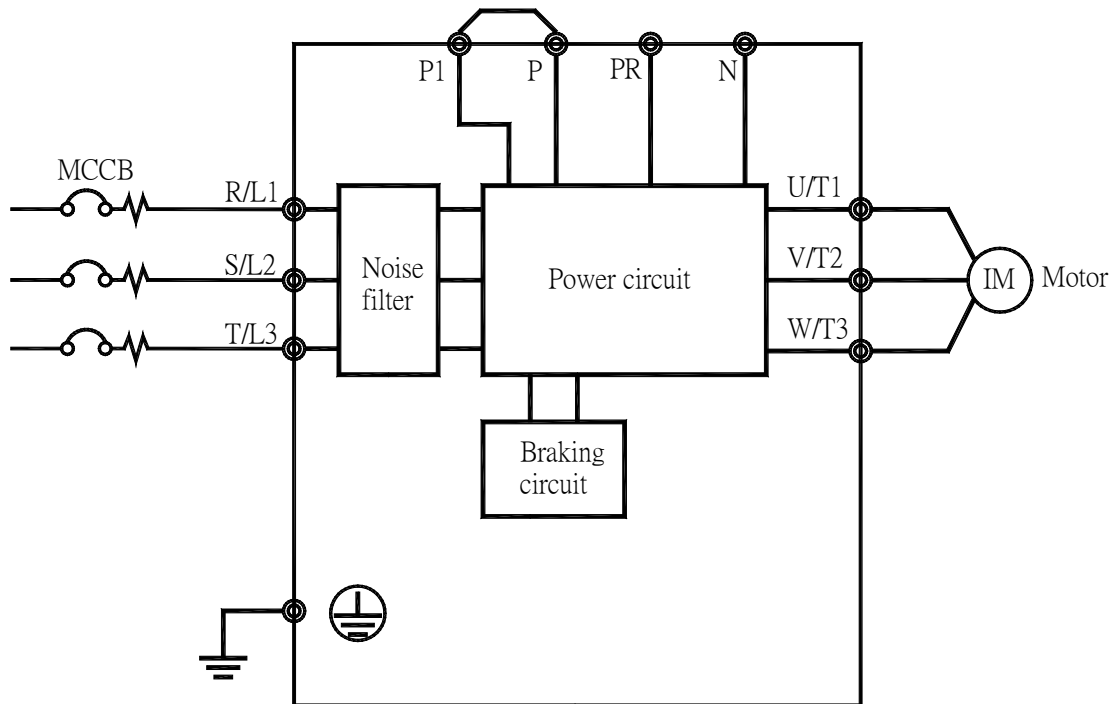

### (1) Wiring



### (2) Parameter setting (default setting)

Title	Function	Programmed value
<b>U-01</b>	Command mode selection	1
<b>U-02</b>	Frequency setting mode selection	0

### (3) Operation

Run / Stop: Press the  and  keys on the panel.

Frequency setting: Set adjusting position of notches on the potentiometer.

Ex.2 Setting the operation frequency using the operation panel and running and stopping using the operation panel.

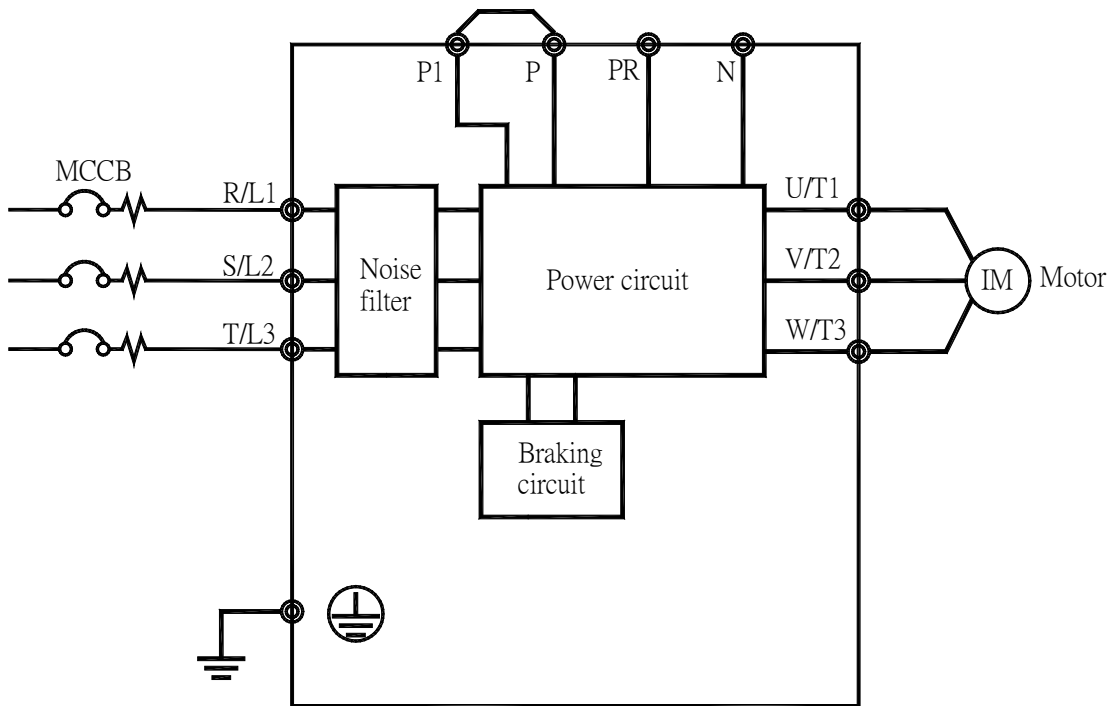

(1) Wiring



(2) Parameter setting

Title	Function	Programmed value
<b>U-01</b>	Command mode selection	1
<b>U-02</b>	Frequency setting mode selection	3

(3) Operation

Run / Stop: Press the  and  keys on the panel.

Frequency setting: Set with the   keys on the operation panel.

To store the set frequencies in memory, press the  key.

**F** and the set frequency will flash on and off alternately.

Ex.3 Setting the operation frequency using built-in potentiometer and running and stopping using external signals.

(1) Wiring

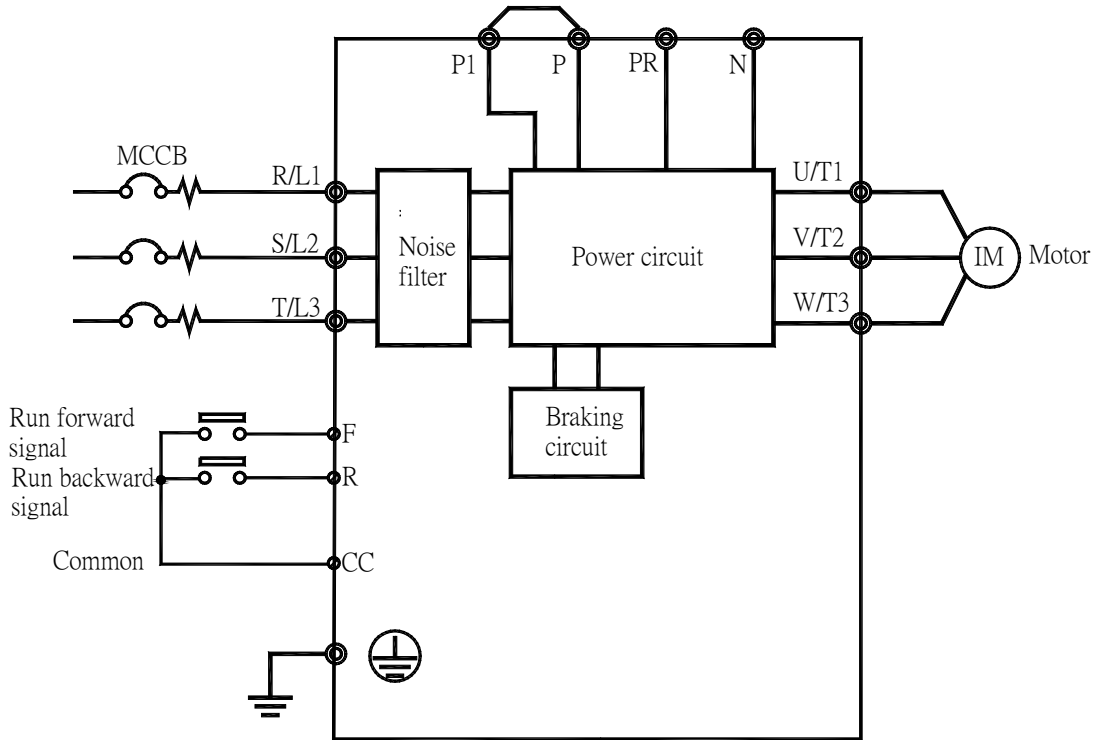

(2) Parameter setting

Title	Function	Programmed value
<b>U-01</b>	Command mode selection	0
<b>U-02</b>	Frequency setting mode selection	0

(3) Operation

Run / Stop: ON/OFF input to F-CC, R-CC. (Set SW1 to Sink logic NPN position)

Frequency setting: Set adjusting position of notches on the potentiometer.

## Ex.4 Operation frequency setting, running and stopping using external signals.

### (1) Wiring

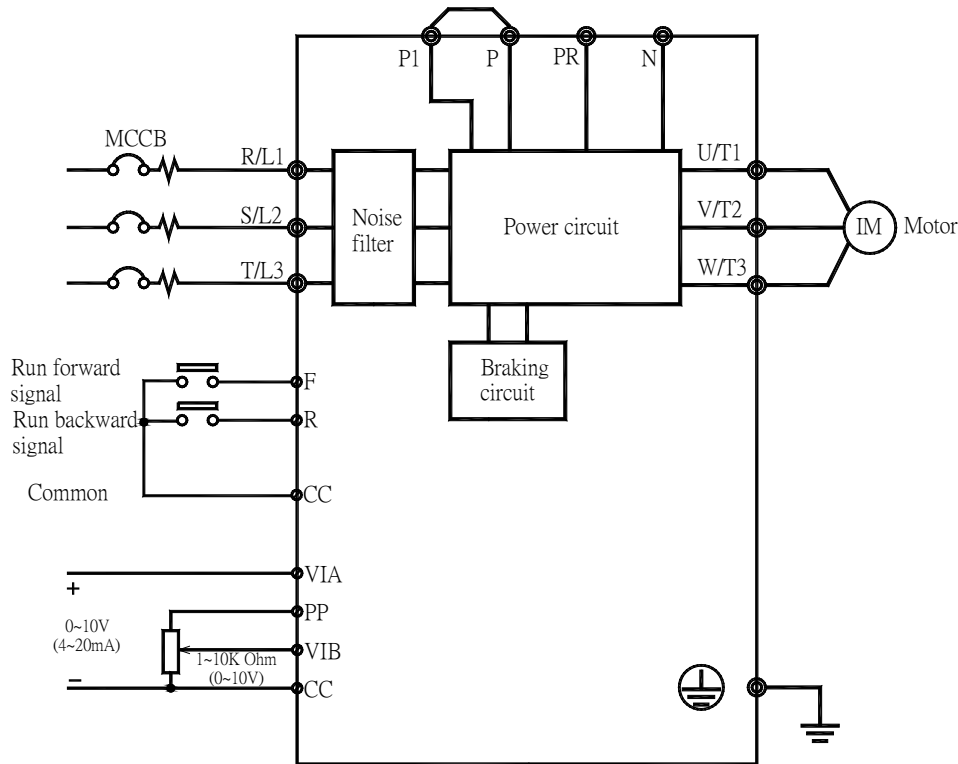

### (2) Parameter setting

Title	Function	Programmed value
<b>U-01</b>	Command mode selection	0
<b>U-02</b>	Frequency setting mode selection	1 or 2

### (3) Operation

Run / Stop: ON/OFF input to F-CC, R-CC. (Set SW1 to Sink logic NPN position)

Frequency setting: VIA and VIB: 0-10Vdc (External potentiometer)

VIA: Input 4-20mA dc.

Use the VIA slide switch SW2 to switch between voltage and current to the VIA terminal.

Voltage input: V side

Current input: I side

## 4. Basic EI-650 operations

The EI-650 has the following four monitor modes.

Standard monitor mode

:The standard inverter mode. This mode is enabled when inverter power goes on.

This mode is for monitoring the output frequency and setting the frequency designated value. In it is also displayed information about status alarms during running and trips.

- Setting frequency designated values → see 3.1.2 (Page 3-3)
- Status alarm

If there is an error in the inverter, the alarm signal and the frequency will flash alternately in the LED display.

**Ⓛ** : When a current flows at or higher than the overcurrents stall level.

**Ⓟ** : When a voltage is generated at or higher than the over voltage stall level.

**Ⓛ** : When a load reaches 50% or higher of the overload trip value.

**Ⓜ** : When the temperature reaches the overheating

Setting monitor mode

: The mode for setting inverter parameters.

How to set parameters → see 4.2 (Page 4-3)

Status monitor mode

: The mode for monitoring all inverter status. Allows monitoring of set frequencies, output current/voltage and terminal information.

For more on how to use the monitor → see 8.1 (Page 8-1)

Pressing the key  will move the inverter through each of the modes.

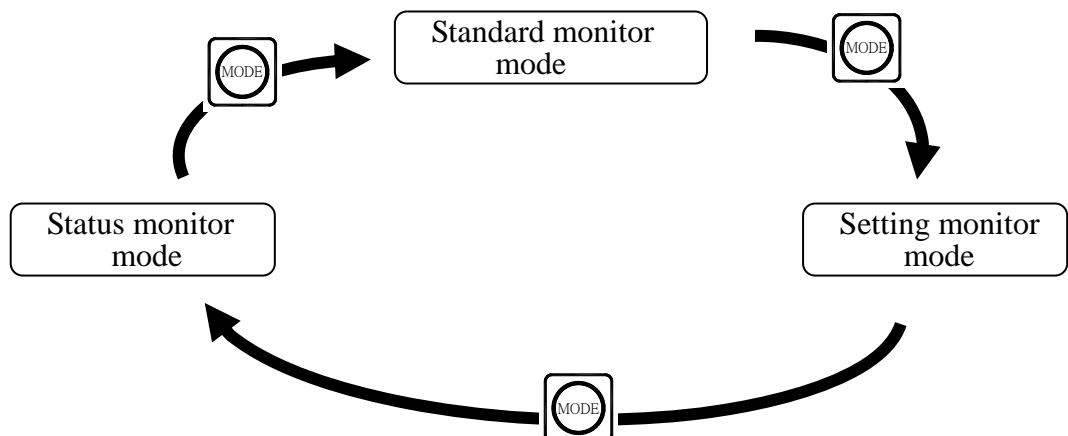

Panel jog mode

: This mode allows you to jog the motor by controlling the operation from the operation panel.  
This mode is hidden by default.

To use the panel jog mode, set the parameter **b-62** to **1**.

Jog run mode → see 7.9 (Page 7-28)

## 4.1 Flow of status monitor mode

Flow of monitor as following

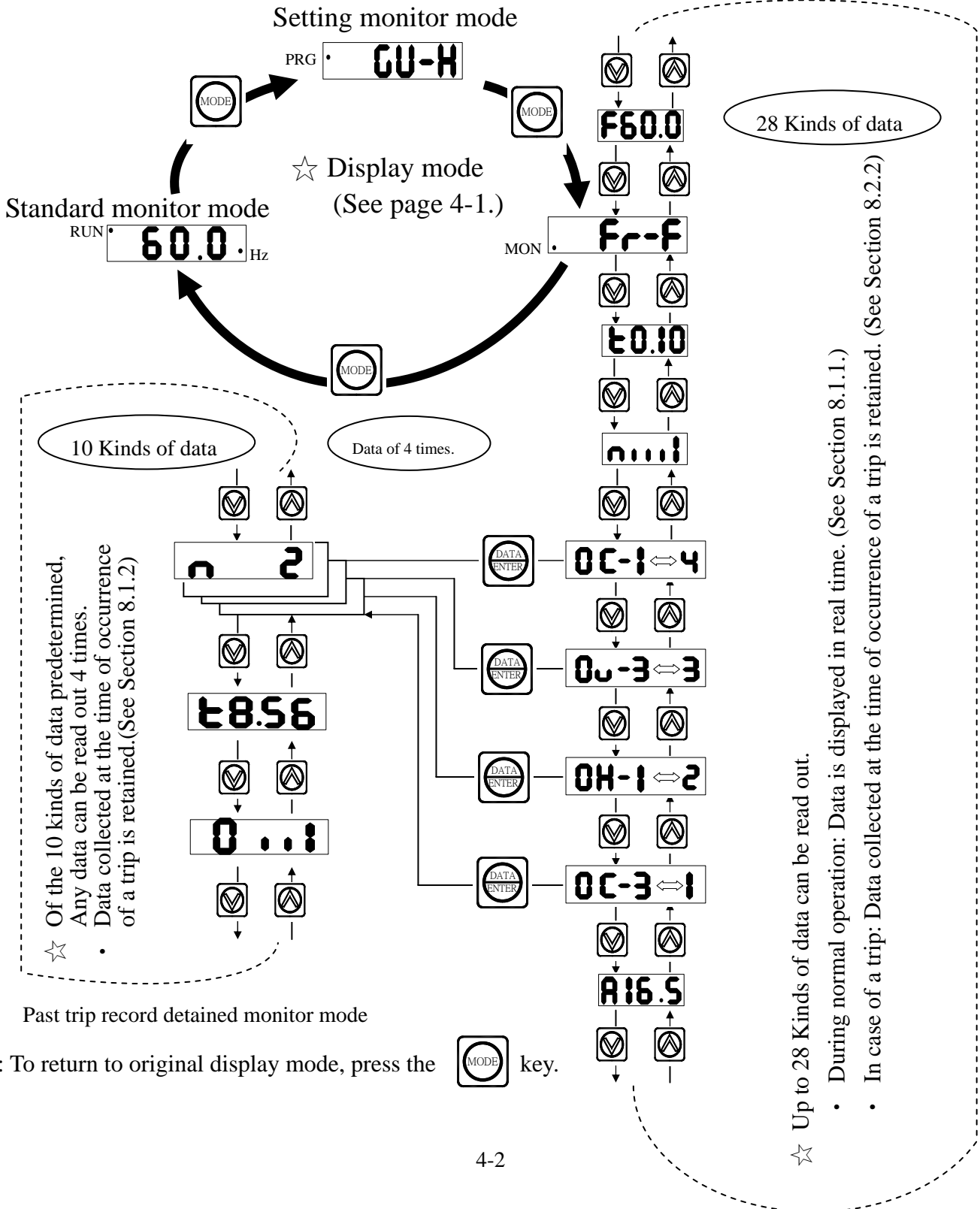

## 4.2 How to set parameters

The standard default parameters are programmed before the unit is shipped from the factory. Parameters can be divided into 4 major categories. Select the parameter to be changed or to be searched and retrieved.

### Basic parameters

: The basic parameters that must be programmed before the first use. (See 4.2.1 Page 4-4)

### Extended parameters

: The parameters for detailed and special setting. (See 4.2.2 Page 4-5)

### User parameters

(automatic edit function)

: Indicates parameters that are different from the standard default setting parameters. Use them to check after setting and to change setting. (Parameter title: **U-26**). (See 4.2.3 Page 4-6)

### History parameter

: This parameter has the function of displaying, in reverse chronological order, the five parameters that were changed last. This function comes in very handy when you adjust the inverter repeatedly using the same parameter. (Parameter name: **CU-H**). (See 4.2.4 Page 7-8)

#### \* Adjustment range of parameters

**H I** : An attempt has been made to assign a value that is higher than the programmable range. Or, as a result of changing other parameters, the programmed value of the parameter that is now selected exceeds the upper limit.

**LO** : An attempt has been made to assign a value that is lower than the programmable range. Or, as a result of changing other parameters, the programmed value of the parameter that is now selected exceeds the lower limit.

If the above alarm is flashing on and off, no setting can be done of values that are equal to or greater than **H I** or equal to or lower than **LO**.

## 4.2.1 How to set the basic parameters

All of the basic parameters can be set by the same step procedures.

[ Steps in key entry for basic parameters]

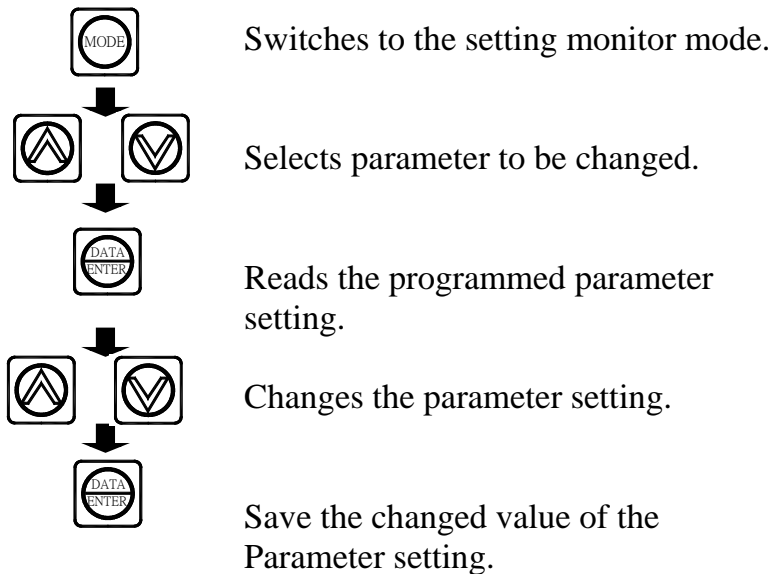

- \* Parameters were factory-set by default before shipment.
- \* Select the parameter to be change from “ Table of parameters”.
- \* If there is something that you do not understand during the operation, press the key to return to the **00** indication.
- \* See 5.2 Page 5-1 for basic parameters.

Steps in setting are as follows (example of changing the maximum frequency from 80Hz to 60Hz).

Key operated	LED display	Operation
	<b>00</b>	Displays the operation frequency (operation stopped). (When standard monitor display selection <b>H- 10 = 0</b> [Operation frequency])
	<b>0U-H</b>	The first basic parameter “ <b>0U-H</b> ” (history function) is displayed.
	<b>U-09</b>	Press either the  or  key to select “ <b>U-09</b> ”.
	<b>800</b>	Pressing the  key reads the maximum frequency.
	<b>600</b>	Press the  key to change the maximum frequency to 60Hz.
	<b>600 ⇄ U-09</b>	Press the  key to save the maximum frequency. <b>U-09</b> And the frequency are displayed alternately.
After this,	→ Displays the same Programmed Parameter.	→ Switches to the display in the Status monitor Mode.
		→ Displays names of parameters.

## 4.2.2 How to set extended parameters

The EI-650 has extended parameters to allow you to make full use of its functions. All extended parameters are expressed with **A~P** and two digits.

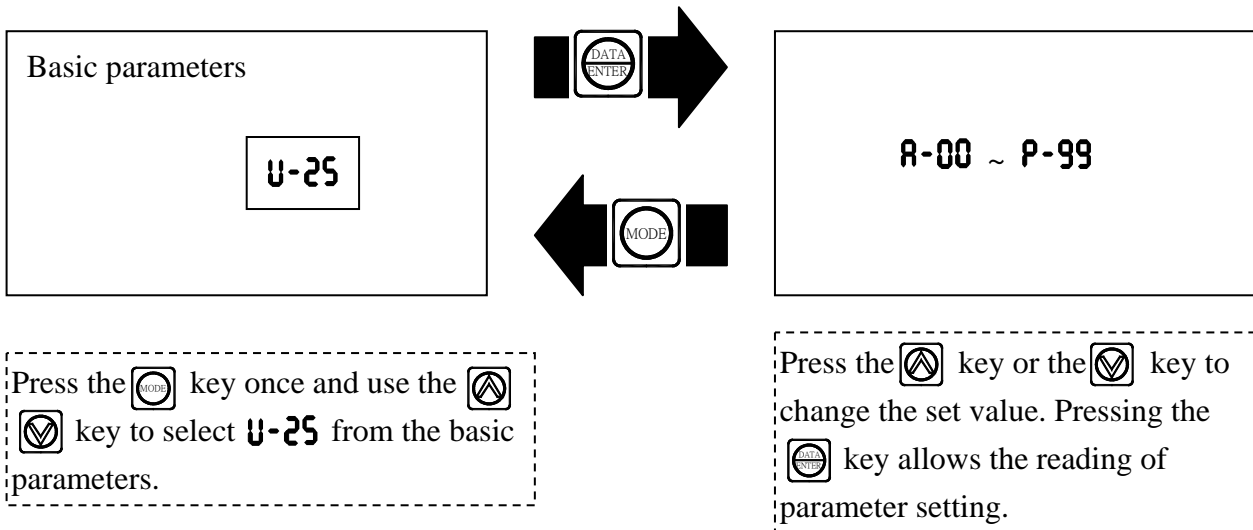



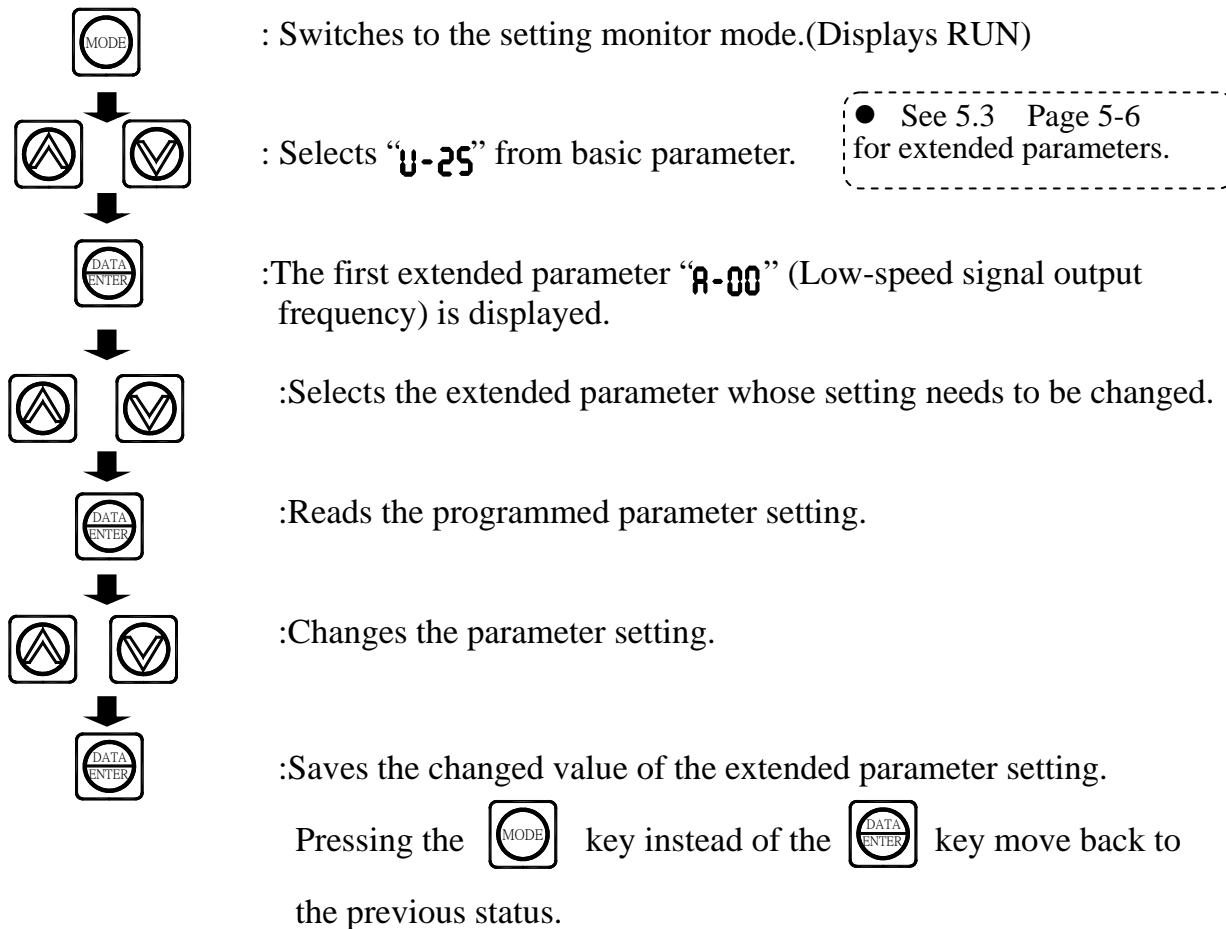













[ Steps in key entry for extended parameters]



■ Example of parameter setting

Steps in setting are as follows

(Example of changing the dynamic braking selection **C-04** from 0 to 1.)

Key operated	LED display	Operation
	<b>00</b>	Displays the operation frequency (operation stopped). (When standard monitor display selection <b>H-10</b> = <b>0</b> [Operation frequency])
	<b>CU-H</b>	The first basic parameter “ <b>CU-H</b> ” (history function) is displayed.
 	<b>U-25</b>	Press either the  or the  to change to the parameter group <b>U-25</b> .
	<b>R-00</b>	Pressing the  key to display the first extended parameter <b>R-00</b> .
 	<b>C-04</b>	Press the  key to change to the dynamic braking selection <b>C-04</b> .
	<b>0</b>	Pressing the  key allows the reading of parameter setting.
 	<b>1</b>	Press the  key to change the dynamic braking selection from <b>0</b> to <b>1</b> .
	<b>1 ⇄ C-04</b>	Pressing the  key alternately flashes on and off the parameter and changed value and allows the save of those values.

If there is anything you do not understand during this operation, press the  key several times to start over from the step of **CU-H** display.

### 4.2.3 Search and resetting of changed parameters (**U-26**)

































Automatically searches for only those parameters that are programmed with values different from the standard default setting and displays them in the user parameter group **U-26**. Parameter setting can also be changed within this group.

#### Notes on operation

- If you reset a parameter to its factory default, the parameter will no longer appear in **U-26**.
- **U-04, d-70 - d-73** are not appeared, if the value of these parameters are changed.

■ How to search and reprogram parameters

The operations of search and resetting of parameters are as follows.

Key operated	LED display	Operation
	00	Displays the operation frequency (operation stopped). (When standard monitor display selection <b>H-10=0</b> [Operation frequency])
	CU-H	The first basic parameter “ <b>CU-H</b> ” (history function) is displayed.
 	U-26	Press  or  key to select <b>U-26</b> .
	U---	Press the  key to enable the user parameter automatic edit function.
 or  	U--F (U--r) ↓ U-07	Searches for parameters that are different in value from the standard default setting and displays those parameters. Press the  key or the  key to change the parameter Displayed. (Pressing the  key moves the search in the reverse direction).
	80	Press the  key to display the value.
 	50	Press the  key and  key to change set value.
	50 = U-07	Press the  key to save the changed value. The parameter name and the programmed value will flash on and off alternately. After the change has been saved, “ <b>U---</b> ” is displayed.
 	U--F (U--r)	Use the same steps as those given above to display parameters that you want to search for or change setting with the  key and  key.
 	U-26	When <b>U-26</b> appears again, the search is ended.
  	U-26 ↓ Fr-F ↓ 00	A search can be canceled by pressing the  key. Press the  key once while the search is underway to return to the display of parameter setting mode. After that you can press the  key to return to the status monitor mode or the standard monitor mode (display of operation frequency).

If there is anything you do not understand during this operation, press the  key several times to start over from the step of **CU-H** display.

#### 4.2.4 Searching for a history of changes, using the history function (CU-H)

















History function (CU-H):





Automatically searches for 5 latest parameters that are programmed with values different from the standard default setting and displays them in the CU-H. Parameter setting can also be changed within this group CU-H.

Notes on operation

- If no history information is stored, this parameter is skipped and the next parameter “CU-1” is displayed.
- **HEAD** and **End** are added respectively to the first and last parameters in a history of changes.

#### ■ How to use the history function

Key operated	LED display	Operation
	00	Displays the operation frequency (operation stopped). (When standard monitor display selection H-10=0[Operation frequency])
	CU-H	The first basic parameter “CU-H” (history function) is displayed.
	U-07	The parameter that was set or changed last is displayed.
	80	Press the  key to display the set value.
 	50	Press the  key and  key to change set value.
	50 ⇄ U-07	Press the  key to save the changed value. The parameter name and the programmed value will flash on and off alternately.
 	****	Use the same steps as those given above to display parameters that you want to search for or change setting with the  key and  key.
 	<b>HEAD</b> ( <b>End</b> )	<b>HEAD</b> : First historic record <b>End</b> : Last historic record

Key operated	LED display	Operation
  	Parameter display ↓ <b>CU-H</b> ↓ <b>Fr-F</b> ↓ <b>00</b>	Press the  key to return to the parameter setting mode “ <b>CU-H</b> .” After that you can press the  key to return to the status Monitor mode or the standard monitor mode (display of operation frequency).

Note) Parameter **H-00** (Prohibition of change of parameter settings ) is not displayed in this “**CU-H**”.

#### 4.2.5 Parameters that cannot be changed while running

For safety reasons, the following parameters have been set up so that they cannot be reprogrammed while the inverter is running. Stop operation (“**00**” or “**OFF**” is displayed) before changing parameter settings.

[Basic parameters ]

**CU-1** ( Automatic acceleration / deceleration)

**CU-2** ( Parameter setting macro torque boost )

**CU-4** ( Parameter setting macro function )

**U-01** ( Command mode selection )

**U-02** ( Frequency setting mode selection 1 )

**U-05** ( Default setting )

**U-09** ( Maximum frequency )

**U-10** ( Base frequency 1 )

**U-13** ( Base frequency voltage1 )

**U-14** ( V/F control mode selection 1 )

} Set **H-36** , and they can be changed while the inverter is running.

[Extended parameters]

**A-05** : Priority selection

**A-09 ~ A-18** : Input terminal selection parameters

**A-30 ~ A-39** : Output terminal selection parameters

**A-70** : Base frequency 2

**A-71** : Base frequency voltage 2

**b-61** : Jog stopping pattern

**C-01 ~ C-11** : Protection parameters

**C-16** : Carrier frequency control mode selection

**C-42 ~ C-45** : Braking mode parameters

**d-00** : Auto-tuning

**d-15 ~ d-19** : Motor constant parameters

- d-80 ~ d-94** : Motor control parameters
- F-03** : Emergency stop selection
- F-05** : Output phase failure detection mode selection
- F-08** : Input phase failure detection mode selection
- F-13** : Detection of output short-circuit during start-up selection
- F-26** : Over-voltage stall protection level
- F-27** : Under voltage trip / alarm selection
- F-69** : Logic output / pulse train output selection ( OUT-NO)
- P-10 ~ P-11** : PM motor parameters

The setting of any parameter other than the above can be changed even during operation. Keep in mind, however, that when the parameter **H-00** (prohibition of change of change of parameter settings ) is set to **1** ( prohibited ), no parameters can be set or changed.

#### 4.2.6 Returning all parameters to standard default setting





Setting the standard default setting parameter **U-05 = 3** , all parameters can be returned to the those factory default settings.









Note: For more details on the standard default setting parameter **U-05** , see 6.6 (Page 6-14).

##### Notes on operation

- We recommend that before this operation you write down on paper the values of those parameters, because when setting **U-05 = 3**, all parameters with changed values will be returned to standard factory default setting.
- Note that **U-04, U-05, R-09, d-70 - d-73, F-69** and **L-80** will not be reset to their factory default settings.

##### ■ Steps for returning all parameters to standard default setting

Key operated	LED display	Operation
	<b>00</b>	Displays the operation frequency (perform during operation stopped).
	<b>CU-H</b>	The first basic parameter “ <b>CU-H</b> ” (history function) is displayed.
 	<b>U-05</b>	Press the  key or the  key to change to <b>U-05</b> .

Key operated	LED display	Operation
	3 0	Pressing the  key displays the programmed parameters. ( <b>U-05</b> will always display “0 (zero)” on the right, the previous setting on the left. )
 	3 3	Press the  key or the  key to change the set value. To return to standard factory default setting, change to “3”.
	In It	Pressing the  key displays “In It” while returning all parameters to factory default setting.
	00	The monitor returns to the display of setup parameters.

If there is anything you do not understand during this operation, press the  key several times to start over from the step of **CU-H** display.

#### 4.2.7 How to save / load the user setting parameters

The current setting of all parameters can be stored (saved) in memory at a time by setting the standard setting mode selection parameter **U-05** to **7**. Also, all parameter settings stored in memory can be restored ( loaded ) by setting parameter **U-05** to **8**. This means that you can use this parameter ( **U-05** = **7** and **8** ) as the parameter for your own initial settings ( default settings ).

## 5. Table of parameters and data

### 5.1 User parameters

Title	Function	Unit	Minimum setting unit Panel/Communication	Adjustment range	Default setting	User setting	Reference
<b>Ff</b>	Operation frequency of operation panel	Hz	0.1/0.01	<b>U-11 - U-10</b>	0.0		3.2

### 5.2 Basic parameters

#### ● Four navigation functions

Title	Communication NO.	Function	Unit	Minimum setting unit Panel/Communication	Adjustment range	Default setting	User setting	Reference
<b>CU-H</b>	-	History function	-	-	Displays parameters in groups of five in the reverse order to that in which their settings were changed. * (Possible to edit)	-		4.1.4
<b>CU-1</b>	0010	Automatic acceleration/ deceleration	-	-	0: Disabled (manual) 1: Automatic 2: Automatic (only at acceleration)	0		6.1.1
<b>CU-2</b>	0011	Torque boost setting macro function	-	-	0: Disabled 1: Automatic torque boost + auto-tuning 2: Vector control + auto-tuning 3: Energy saving + auto-tuning	0		6.2
<b>CU-4</b>	0050	Parameter setting macro function	-	-	0: Disabled 1: Coast stop 2: 3-wire operation 3: External input UP/DOWN setting 4: 4-20 mA current input operation	0		6.3

● Basic parameters

Title	Communication NO.	Function	Unit	Minimum setting unit Panel/Communication	Adjustment range	Default setting	User setting	Reference
<b>U-01</b>	0013	Command mode selection	-	-	0: Terminal board 1: Operation panel	1		6.4
<b>U-02</b>	0014	Frequency setting mode selection 1	-	-	0: Built-in potentiometer 1: VIA 2: VIB 3: Operation panel 4: Serial communication 5: UP/DOWN from external contact 6: VIA + VIB (Override)	0		6.4 7.5.1
<b>U-03</b>	0015	Meter selection	-	-	0: Output frequency 1: Output current 2: Set frequency 3: DC voltage 4: Output voltage command value 5: Input power 6: Output power 7: Torque 8: Torque current 9: Motor cumulative load factor 10: Inverter cumulative load factor 11: PBR(braking reactor) cumulative load factor 12: Frequency setting value (after PID) 13: VIA Input value 14: VIB Input value 15: Fixed output 1 (Output current:100%) 16: Fixed output 2 (Output current: 50%) 17: Fixed output 3 (Other than the output current : 100%) 18: Serial communication data 19: For adjustments ( <b>U-04</b> set value is displayed.)	0		6.5

Title	Communication NO.	Function	Unit	Minimum setting unit Panel/Communication	Adjustment range	Default setting	User setting	Reference
<b>U-04</b>	0016	Meter adjustment	-	-	-	-		6.5
<b>U-05</b>	0017	Default setting	-	-	0: - 1: 50Hz default setting 2: 60Hz default setting 3: Default setting (Initialization) 4: Trip record clear 5: Cumulative operation time clear 6: Initialization of type information 7: Save user setting parameters 8. Load user setting parameters 9. Cumulative fan operation time record clears	0		4.2.6 4.2.7 6.6
<b>U-06</b>	0018	Forward/reverse run selection (Operation panel)	-	-	0: Forward run 1: Reverse run 2: Forward run (F/R switching possible ) 3: Reverse run (F/R switching possible)	0		6.7
<b>U-07</b>	0019	Acceleration time 1	S	0.1/0.1	0.0 - 3200	10.0		6.1.2
<b>U-08</b>	0020	Deceleration time 1	S	0.1/0.1	0.0 - 3200	10.0		6.1.2
<b>U-09</b>	0021	Maximum frequency	Hz	0.1/0.01	30.0 - 500.0	80.0		6.8
<b>U-10</b>	0022	Upper limit frequency	Hz	0.1/0.01	0.5 - <b>U-09</b>	50.0		6.9
<b>U-11</b>	0023	Lower limit frequency	Hz	0.1/0.01	0.0 - <b>U-10</b>	0.0		6.9
<b>U-12</b>	0024	Base frequency 1	Hz	0.1/0.01	25 - 500.0	50.0		6.10
<b>U-13</b>	0403	Base Frequency voltage 1	V	1/0.1	50-330 (240V class) 50-660 (480V class)	*3		6.10 7.13.6

\*3 : 230 (240V class), 460 (480V class)

Title	Communication NO.	Function	Unit	Minimum setting unit Panel/Communication	Adjustment range	Default setting	User setting	Reference																															
<b>U-14</b>	0025	V/F control mode selection	-	-	0: V/F constant 1: Variable torque 2: Automatic torque boost control 3: Vector control 4: Energy-saving 5: Dynamic energy-saving (for fans and pumps) 6: PM motor control	2		6.11																															
<b>U-15</b>	0026	Torque boost value 1	%	0.1/0.1	0.0 - 30.0	* 1		6.12																															
<b>U-16</b>	0600	Motor Electronic-thermal protection level 1	% (A)	1/1	10 - 100	100		6.13 7.19.1																															
<b>U-17</b>	0027	Electronic-thermal protection characteristic selection *2		-	<table border="1"> <thead> <tr> <th>Setting</th> <th></th> <th>Overload protection</th> <th>OL stall</th> </tr> </thead> <tbody> <tr> <td>0</td> <td rowspan="3">Standard motor</td> <td>○</td> <td>×</td> </tr> <tr> <td>1</td> <td>○</td> <td>○</td> </tr> <tr> <td>2</td> <td>×</td> <td>×</td> </tr> <tr> <td>3</td> <td rowspan="4">VF motor</td> <td>×</td> <td>○</td> </tr> <tr> <td>4</td> <td>○</td> <td>×</td> </tr> <tr> <td>5</td> <td>○</td> <td>○</td> </tr> <tr> <td>6</td> <td>×</td> <td>×</td> </tr> <tr> <td>7</td> <td></td> <td>×</td> <td>○</td> </tr> </tbody> </table>	Setting		Overload protection	OL stall	0	Standard motor	○	×	1	○	○	2	×	×	3	VF motor	×	○	4	○	×	5	○	○	6	×	×	7		×	○	0		6.13
Setting		Overload protection	OL stall																																				
0	Standard motor	○	×																																				
1		○	○																																				
2		×	×																																				
3	VF motor	×	○																																				
4		○	×																																				
5		○	○																																				
6		×	×																																				
7		×	○																																				
<b>U-18</b>	0028	Preset-speed operation frequency 1	Hz	0.1/0.01	<b>U-11 - U-10</b>	0.0		6.14																															
<b>U-19</b>	0029	Preset-speed operation frequency 2	Hz	0.1/0.01	<b>U-11 - U-10</b>	0.0																																	
<b>U-20</b>	0030	Preset-speed operation frequency 3	Hz	0.1/0.01	<b>U-11 - U-10</b>	0.0																																	
<b>U-21</b>	0031	Preset-speed operation frequency 4	Hz	0.1/0.01	<b>U-11 - U-10</b>	0.0																																	
<b>U-22</b>	0032	Preset-speed operation frequency 5	Hz	0.1/0.01	<b>U-11 - U-10</b>	0.0																																	
<b>U-23</b>	0033	Preset-speed operation frequency 6	Hz	0.1/0.01	<b>U-11 - U-10</b>	0.0																																	
<b>U-24</b>	0034	Preset-speed operation frequency 7	Hz	0.1/0.01	<b>U-11 - U-10</b>	0.0																																	

Title	Communication NO.	Function	Unit	Minimum setting unit Panel/Communication	Adjustment range	Default setting	User setting	Reference
<b>U-25</b>	-	Extended parameters	-	-	-	-	-	
<b>U-26</b>	-	Automatic edit function	-	-	-	-	-	

\*1 : Default values vary depending on the capacity. See the table of the page 5-21.

\*2 : ○: valid, × : invalid

## 5.3 Extended parameters

### ● Input / output parameters 1

Title	Communication NO.	Function	Unit	Minimum setting unit Panel/Communication	Adjustment range	Default setting	User setting	Reference
<b>A-00</b>	0100	Low-speed signal output frequency	Hz	0.1/0.01	0.0 - <b>U-09</b>	0.0		7.1.1
<b>A-01</b>	0101	Speed reach setting frequency	Hz	0.1/0.01	0.0 - <b>U-09</b>	0.0		7.1.3
<b>A-02</b>	0102	Speed reach detection band	Hz	0.1/0.01	0.0 - <b>U-09</b>	2.5		7.1.2
<b>A-05</b>	0103	Priority selection (Both F-CC and R-CC are ON)	-	-	0: Reverse 1: Slowdown Stop	1		7.2.1
<b>A-09</b>	0104	Analog/contact input function selection (VIA/VIB terminal)	-	-	0: Analog input for communications VIB-analog input ----- 1: VIA-analog input VIB-contact input (Sink) ----- 2: VIA-analog input VIB-contact input (Source) ----- 3: VIA-contact input (Sink) VIB-contact input (Sink) ----- 4: VIA-contact input (Source) VIB-contact input (Source)	0		7.2.2
<b>A-10</b>	0105	Always-active function selection 2	-	-	0-65 (ST)	1		7.3.1
<b>A-11</b>	0106	Input terminal selection1 (F)	-	-	0-65 (F)	2		7.3.2
<b>A-12</b>	0107	Input terminal selection2 (R)	-	-	0-65 (R)	3		
<b>A-13</b>	0108	Input terminal selection3 (RES)	-	-	0-65 (RES)	10		
<b>A-14</b>	0109	Input terminal selection4 (S1)	-	-	0-65 (SS1)	6		
<b>A-15</b>	0110	Input terminal selection5 (S2)	-	-	0-65 (SS2)	7		
<b>A-16</b>	0111	Input terminal selection6 (S3)	-	-	0-65 (SS3)	8		
<b>A-17</b>	0112	Input terminal selection7 (VIB)	-	-	5-17 (SS4)	9		

Title	Communication NO.	Function	Unit	Minimum setting unit Panel/Communication	Adjustment range	Default setting	User setting	Reference
<b>A-18</b>	0113	Input terminal selection8 (VIA)	-	-	5-17 (AD2)	5		7.3.2
<b>A-30</b>	0114	Output terminal selection 1A (RY-RC)	-	-	0-255 (LOW)	4		7.3.3
<b>A-31</b>	0115	Output terminal selection 2A (OUT-NO)	-	-	0-255 (RCH)	6		
<b>A-32</b>	0116	Output terminal selection 3 (FL)	-	-	0-255 (FL)	10		
<b>A-37</b>	0117	Output terminal selection 1B (RY-RC)	-	-	0-255 (always ON)	255		7.3.4
<b>A-38</b>	0118	Output terminal selection 2B (OUT-NO)	-	-	0-255 (always ON)	255		
<b>A-39</b>	0119	Output terminal logic selection (RY-RC, OUTNO)	-	-	0: <b>A-30</b> and <b>A-37</b> <b>A-31</b> and <b>A-38</b> ----- 1: <b>A-30</b> or <b>A-37</b> <b>A-31</b> and <b>A-38</b> ----- 2: <b>A-30</b> and <b>A-37</b> <b>A-31</b> or <b>A-38</b> ----- 3: <b>A-30</b> or <b>A-37</b> <b>A-31</b> or <b>A-38</b>	0		7.3.4
<b>A-67</b>	0120	Frequency command agreement detection range	Hz	0.1/0.01	0.0 - <b>U-09</b>	2.5		7.3.5
<b>A-70</b>	0121	Base frequency 2	Hz	0.1/0.01	25.0 - 500.0	50.0		7.4.1
<b>A-71</b>	0122	Base frequency voltage 2	V	1/0.1	50-330 (240V class) 50-660 (480V class)	*3		
<b>A-72</b>	0123	Torque boost value 2	%	0.1/0.1	0.0 - 30.0	*1		
<b>A-73</b>	0124	Motor electronic-thermal protection level 2	% (A)	1/1	10 - 100	100		6.13 7.4.1
<b>A-85</b>	0125	Stall prevention level 2	% (A)	1/1	10-199, 200 (disabled)	150		7.4.1 7.19.2

\*1 : Default values vary depending on the capacity. See the table of page 5-21.

\*3 : 230 (240V class), 460 (480V class)

● Frequency parameters

Title	Communication NO.	Function	Unit	Minimum setting unit Panel/Communication	Adjustment range	Default setting	User setting	Reference
<b>b-00</b>	0200	Frequency priority selection	-	-	0: <b>U-02</b> (Switchable to <b>b-07</b> by terminal input)	0		7.5.1
					1: <b>U-02</b> (Switchable to <b>b-07</b> at less than 1.0Hz of designated frequency)			
<b>b-01</b>	0201	VIA input point 1 setting	%	1/1	0 - 100	0		7.5.2
<b>b-02</b>	0202	VIA input point 1 frequency	Hz	0.1/0.01	0.0 - 500.0	0.0		
<b>b-03</b>	0203	VIA input point 2 setting	%	1/1	0 - 100	100		
<b>b-04</b>	0204	VIA input point 2 frequency	Hz	0.1/0.01	0.0 - 500.0	50.0		
<b>b-07</b>	0207	Frequency setting mode selection 2	-	-	0: Built-in potentiometer 1: VIA 2: VIB 3: Operation panel 4: Serial communication 5: UP/DOWN from external contact 6: VIA+VIB (Override)	1		7.3.5 7.5.1
<b>b-10</b>	0210	VIB input point 1 setting	%	1/1	0 - 100	0		7.5.2
<b>b-11</b>	0211	VIB input point 1 frequency	Hz	0.1/0.01	0.0 - 500.0	0.0		
<b>b-12</b>	0212	VIB input point 2 setting	%	1/1	0 - 100	100		
<b>b-13</b>	0213	VIB input point 2 frequency	Hz	0.1/0.01	0.0 - 500.0	50.0		
<b>b-40</b>	0240	Starting frequency setting	Hz	0.1/0.01	0.5 - 10.0	0.5		7.6.1
<b>b-41</b>	0241	Operation starting frequency	Hz	0.1/0.01	0.0 - <b>U-09</b>	0.0		7.6.2
<b>b-42</b>	0242	Operation starting frequency hysteresis	Hz	0.1/0.01	0.0 - <b>U-09</b>	0.0		7.6.2

Title	Communication NO.	Function	Unit	Minimum setting unit Panel/Communication	Adjustment range	Default setting	User setting	Reference
<b>b-50</b>	0213	DC braking starting frequency	Hz	0.1/0.01	0.0 - <b>U-09</b>	0.0		7.7.1
<b>b-51</b>	0214	DC braking current	%(A)	1/1	0 - 100	50		
<b>b-52</b>	0215	DC braking time	s	0.1/0.1	0.0 - 20.0	1.0		
<b>b-54</b>	0216	Motor shaft fixing control	-	-	0: Disabled 1: Enabled (after DC braking)	0		7.7.2
<b>b-56</b>	0217	Time limit for lower – limit frequency operation	s	0.1/0.1	0: Disabled 0.1-600.0	0.0		7.8
<b>b-60</b>	0218	Jog run frequency	Hz	0.1/0.01	<b>b-40</b> - 20.0	5.0		7.9
<b>b-61</b>	0219	Jog run stopping pattern	-	-	0: Slowdown stop 1: Coast stop 2: DC braking	0		
<b>b-62</b>	0220	Panel jog run operation mode	-	-	0: Invalid 1: Valid	0		
<b>b-64</b>	0221	Input from external contacts - UP response time	s	0.1/0.1	0.0 - 10.0	0.1		7.5.2
<b>b-65</b>	0222	Input from external contacts - UP frequency step width	Hz	0.1/0.01	0.0 - <b>U-09</b>	0.1		
<b>b-66</b>	0223	Input from external contacts - DOWN response time	s	0.1/0.1	0.0 - 10.0	0.1		
<b>b-67</b>	0224	Input from external contacts - DOWN frequency step width	Hz	0.1/0.01	0.0 - <b>U-09</b>	0.1		
<b>b-68</b>	0225	Initial value of UP/DOWN frequency	Hz	0.1/0.01	<b>U-11</b> - <b>U-10</b>	0.0		
<b>b-69</b>	0226	Saving of changed value of UP/DOWN frequency	-	-	0: Not changed 1: Setting of <b>b-68</b> changed when power is turned off	1		
<b>b-70</b>	0227	Jump frequency 1	Hz	0.1/0.01	0.0 - <b>U-09</b>	0.0		
<b>b-71</b>	0228	Jumping width 1	Hz	0.1/0.01	0.0 - 30.0	0.0		7.10
<b>b-72</b>	0229	Jump frequency 2	Hz	0.1/0.01	0.0 - <b>U-09</b>	0.0		

Title	Communication NO.	Function	Unit	Minimum setting unit Panel/Communication	Adjustment range	Default setting	User setting	Reference
<b>b-73</b>	0230	Jumping width 2	Hz	0.1/0.01	0.0 - 30.0	0.0		7.10
<b>b-74</b>	0231	Jump frequency 3	Hz	0.1/0.01	0.0 - <b>U-09</b>	0.0		
<b>b-75</b>	0232	Jumping width 3	Hz	0.1/0.01	0.0 - 30.0	0.0		
<b>b-87</b>	0233	Preset-speed operation frequency 8	Hz	0.1/0.01	<b>U-11 - U-10</b>	0.0		6.14
<b>b-88</b>	0234	Preset-speed operation frequency 9	Hz	0.1/0.01	<b>U-11 - U-10</b>	0.0		
<b>b-89</b>	0235	Preset-speed operation frequency 10	Hz	0.1/0.01	<b>U-11 - U-10</b>	0.0		
<b>b-90</b>	0236	Preset-speed operation frequency 11	Hz	0.1/0.01	<b>U-11 - U-10</b>	0.0		
<b>b-91</b>	0237	Preset-speed operation frequency 12	Hz	0.1/0.01	<b>U-11 - U-10</b>	0.0		
<b>b-92</b>	0238	Preset-speed operation frequency 13	Hz	0.1/0.01	<b>U-11 - U-10</b>	0.0		
<b>b-93</b>	0239	Preset-speed operation frequency 14	Hz	0.1/0.01	<b>U-11 - U-10</b>	0.0		
<b>b-94</b>	0240	Preset-speed operation frequency 15 (Fire-speed)	Hz	0.1/0.01	<b>U-11 - U-10</b>	0.0		

● Operation mode parameters

Title	Communication NO.	Function	Unit	Minimum setting unit Panel/Communication	Adjustment range	Default setting	User setting	Reference
<b>C-00</b>	0300	PWM carrier frequency	kHz	0.1/0.1	2.0 - 16.0	12.0		7.12
<b>C-01</b>	0301	Auto-restart control selection	-	-	0: Disabled 1: At auto-restart after momentary stop 2: ST terminal on or off 3: At auto-restart or when turning ST-CC on or off 4: At start-up	0		7.13.1
<b>C-02</b>	0302	Regenerative power ride-through control (Deceleration stop)	-	-	0: Disabled 1: Automatic setting 2: Slowdown stop	0		7.13.2

Title	Communication NO.	Function	Unit	Minimum setting unit Panel/Communication	Adjustment range	Default setting	User setting	Reference
<b>C-03</b>	0303	Retry selection (number of times)	Times	1/1	0: Disabled 1-10	0		7.13.3
<b>C-04</b>	0304	Dynamic braking selection	-	-	0: Disabled 1: Enabled (Resistor overload protection enabled)	0		7.13.4
<b>C-05</b>	0305	Overvoltage limit operation (Slowdown stop mode selection)	-	-	0: Enabled 1: Disabled 2: Enabled (Quick deceleration) 3: Enabled (Dynamic quick deceleration)	2		7.13.5
<b>C-07</b>	0306	Supply voltage correction (limitation of output voltage)	-	-	0: Supply voltage uncorrected, output voltage limited ----- 1: Supply voltage corrected, output voltage limited ----- 2: Supply voltage uncorrected, output voltage unlimited ----- 3: Supply voltage corrected, output voltage unlimited	2		7.13.6
<b>C-08</b>	0307	Dynamic braking resistance	Ω	0.1/0.1	1.0 - 1000	*1		7.13.4
<b>C-09</b>	0308	Dynamic braking resistor capacity	kW	0.01/0.01	0.01 - 30.00	*1		7.13.4
<b>C-11</b>	0309	Reverse-run prohibition	-	-	0: Forward/reverse run permitted 1: Reverse run prohibited 2: Forward run prohibited	0		7.13.7
<b>C-12</b>	0310	Random mode	-	-	0: Disabled 1: Automatic setting	0		7.12
<b>C-16</b>	0311	Carrier frequency control mode selection	-	-	0: Carrier frequency not reduced automatically ----- 1: Carrier frequency reduced automatically ----- 2: Carrier frequency not reduced automatically Support for 500V/600Vmodels ----- 3: Carrier frequency reduced automatically Support for 500V/600Vmodels	1		7.12

Title	Communication NO.	Function	Unit	Minimum setting unit Panel/Communication	Adjustment range	Default setting	User setting	Reference
<b>C-20</b>	0312	Droop gain	%	1/1	0 - 100	0		7.14
<b>C-23</b>	0313	Droop insensitive torque band	%	1/1	0 - 100	10		7.14
<b>C-42</b>	0314	Braking mode selection	-	-	0: Disabled 1: Enabled (forward run) 2: Enabled (reverse run) 3: Enabled (operation direction)	0		7.15
<b>C-43</b>	0315	Release frequency	Hz	0.1/0.01	<b>b-40</b> - 20.0	3.0		
<b>C-44</b>	0316	Release time	s	0.01/0.01	0.00-2.50	0.05		
<b>C-45</b>	0317	Creeping frequency	Hz	0.1/0.1	<b>b-40</b> - 20.0	3.0		
<b>C-46</b>	0318	Creeping time	s	0.01/0.01	0.00 - 2.50	0.10		
<b>C-59</b>	0319	PID control waiting time	s	1/1	0 - 2400	0		7.16
<b>C-60</b>	0320	PID control	-	-	0: Disabled, 1: Enabled	0		
<b>C-62</b>	0321	Proportional gain	-	0.01/0.01	0.01 - 100.0	0.30		
<b>C-63</b>	0322	Integral gain	-	0.01/0.01	0.01 - 100.0	0.20		
<b>C-66</b>	0323	Differential gain	-	0.01/0.01	0.00 - 2.5	0.00		

\*1: Default values vary depending on the capacity. See the table of 5-21.

### ● Torque boost parameters 1

Title	Communication NO.	Function	Unit	Minimum setting unit Panel/Communication	Adjustment range	Default setting	User setting	Reference
<b>d-00</b>	0400	Auto-tuning	-	-	0: Auto-tuning disabled 1: Initialization of <b>d-02</b> (reset to 0) 2: Auto-tuning enabled (after execution: 0)	0		6.11 7.17.1
<b>d-01</b>	0401	Slip frequency gain	%	1/1	0 - 150	50		
<b>d-02</b>	0402	Automatic torque boost value	%	0.1/0.1	0.0 - 30.0	*1		
<b>d-15</b>	0404	Motor rated current	A	0.1/0.1	0.1 - 100.0	*1		
<b>d-16</b>	0405	Motor no-load current	%	1/1	10 - 90	*1		

Title	Communication NO.	Function	Unit	Minimum setting unit Panel/Communication	Adjustment range	Default setting	User setting	Reference
<b>d-17</b>	0406	Motor rated speed	min-1	1/1	100 - 32000	1410		6.11 7.17.1
<b>d-18</b>	0407	Speed control response coefficient	-	1/1	1 - 150	40		
<b>d-19</b>	0408	Speed control stability coefficient	-	1/1	1 - 100	20		

\*1: Default values vary depending on the capacity. See the table of 5-21.

### ● Input/output parameters 2

Title	Communication NO.	Function	Unit	Minimum setting unit Panel/Communication	Adjustment range	Default setting	User setting	Reference
<b>d-70</b>	0470	VIA input bias	-	-	-	-		7.5.4
<b>d-71</b>	0471	VIA input gain	-	-	-	-		
<b>d-72</b>	0472	VIB input bias	-	-	-	-		
<b>d-73</b>	0473	VIB input gain	-	-	-	-		

### ● Torque boost parameters 2

Title	Communication NO.	Function	Unit	Minimum setting unit Panel/Communication	Adjustment range	Default setting	User setting	Reference
<b>d-80</b>	0480	Exciting current coefficient	%	1/1	100 - 130	100		6.11 7.17.2
<b>d-85</b>	0481	Stall prevention control coefficient 1	-	1/1	10 - 250	100		
<b>d-92</b>	0482	Stall prevention control coefficient 2	-	1/1	50 - 150	100		
<b>d-94</b>	0483	Motor adjustment coefficient	-	1/1	0 - 200	*1		

\*1: Default values vary depending on the capacity. See the table of 5-21.

● Acceleration/deceleration time parameters

Title	Communication NO.	Function	Unit	Minimum setting unit Panel/Communication	Adjustment range	Default setting	User setting	Reference
<b>E-00</b>	0500	Acceleration time 2	s	0.1/0.1	0.0 - 3200	10.0		7.18
<b>E-01</b>	0501	Deceleration time 2	s	0.1/0.1	0.0 - 3200	10.0		
<b>E-02</b>	0502	Acceleration/deceleration 1 pattern	-	-	0: Linear 1: S-pattern 1 2: S-pattern 2	0		
<b>E-03</b>	0503	Acceleration/deceleration 2 pattern	-	-		0		
<b>E-04</b>	0504	Acceleration/deceleration selection (1, 2, 3)	-	-	1: Acceleration/deceleration 1 2: Acceleration/deceleration 2 3: Acceleration/deceleration 3	1		
<b>E-05</b>	0505	Acceleration/deceleration 1 and 2 switching frequency	Hz	0.1/0.1	0.0 - <b>U-10</b>	0.0		
<b>E-06</b>	0506	S-pattern lower-limit adjustment amount	%	1/1	0 - 50	10		
<b>E-07</b>	0507	S-pattern upper-limit adjustment amount	%	1/1	0 - 50	10		7.18
<b>E-10</b>	0508	Acceleration time 3	s	0.1/0.1	0.0 - 3200	10.0		
<b>E-11</b>	0509	Deceleration time 3	s	0.1/0.1	0.0 - 3200	10.0		
<b>E-12</b>	0510	Acceleration/deceleration 3 pattern	-	-	0: Linear 1: S-pattern 1 2: S-pattern 2	0		
<b>E-13</b>	0511	Acceleration/deceleration 2 and 3 switching frequency	Hz	0.1/0.1	0.0 - <b>U-10</b>	0.0		

● Protection parameters

Title	Communication NO.	Function	Unit	Minimum setting unit Panel/Communication	Adjustment range	Default setting	User setting	Reference
<b>F-01</b>	0601	Stall prevention level 1	% (A)	1/1	10-199 , 200 (disabled)	150		7.19.2
<b>F-02</b>	0602	Inverter trip retention selection	-	-	0: Canceled with the power off 1: Still retained with the power off	0		7.19.3
<b>F-03</b>	0603	Emergency stop selection	-	-	0: Coast stop 1: Slowdown stop 2: Emergency DC braking	0		7.19.4
<b>F-04</b>	0604	Emergency DC braking time	s	0.1/0.1	0.0 - 20.0	1.0		7.19.4
<b>F-05</b>	0605	Output phase failure detection mode selection	-	-	0: Disabled 1: At start-up (only one time after power is turned on) 2: At start-up (each time) 3: During operation 4: At start-up + during operation 5: Detection of cutoff on output side	0		7.19.5
<b>F-07</b>	0606	Motor 150% -overload time limit	s	1/1	10 - 2400	300		7.19.1
<b>F-08</b>	0607	Input phase failure detection mode selection	-	-	0: Disabled, 1: Enabled	1		7.19.6
<b>F-10</b>	0608	Small current trip/alarm selection	-	-	0: Alarm only 1: Tripping	0		7.19.7
<b>F-11</b>	0609	Small current detection current	% (A)	1/1	0 - 100	0		
<b>F-12</b>	0610	Small current detection time	s	1/1	0 - 255	0		
<b>F-13</b>	0611	Detection of output short-circuit during start-up	-	-	0: Each time (standard pulse) 1: At start-up (only one time after power is turned on) (standard pulse) 2: Each time (short-time pulse) 3: At start-up (only one time after power is turned on) (short-time pulse)	0		7.19.8

Title	Communication NO.	Function	Unit	Minimum setting unit Panel/Communication	Adjustment range	Default setting	User setting	Reference
<b>F-15</b>	0612	Over-torque trip/alarm selection	-	-	0: Alarm only 1: Tripping	0		7.19.9
<b>F-16</b>	0613	Over-torque detection level	%	1/1	0 - 250	150		
<b>F-18</b>	0614	Over-torque detection time	s	0.1/0.1	0.0 - 10.0	0.5		
<b>F-19</b>	0615	Over-torque detection level hysteresis	%	1/1	0 - 100	10		7.19.9
<b>F-21</b>	0616	Cumulative operation time alarm setting	100 Time	0.1/0.1 (=10 hours)	0.0 - 999.9	610		7.19.10
<b>F-26</b>	0617	Over-voltage stall protection level	%	1/1	100 - 150	*1		7.13.5
<b>F-27</b>	0618	Undervoltage trip/alarm selection	-	-	0: Alarm only (detection level below 60%) 1: Tripping (detection level below 60%) 2: Alarm only (detection level below 50%, DC reactor necessary)	0		7.19.12
<b>F-33</b>	0619	Trip at VIA low level input mode	%	1/1	0: Disabled, 1-100	0		7.19.13
<b>F-34</b>	0620	Annual average ambient temperature (parts replacement alarms)	-	-	1: -10 to +10 °C 2: 11-20 °C 3: 21-30 °C 4: 31-40 °C 5: 41-50 °C 6: 51-60 °C	3		7.19.14

\*1: Default values vary depending on the capacity. See the table of 5-21.

### ● Output parameters

Title	Communication NO.	Function	Unit	Minimum setting unit Panel/Communication	Adjustment range	Default setting	User setting	Reference
<b>F-69</b>	0669	Logic output/pulse train output selection (OUT- NO)	-	-	0: Logic output 1: Pulse train output	0		7.20.1

Title	Communication NO.	Function	Unit	Minimum setting unit Panel/Communication	Adjustment range	Default setting	User setting	Reference
<b>F-76</b>	0670	Pulse train output function selection (OUT-NO)	-	-	0: Output frequency 1: Output current 2: Set frequency 3: DC voltage 4: Output voltage command value 5: Input power 6: Output power 7: Torque 8: Torque current 9: Motor cumulative load factor 10: Inverter cumulative load factor 11: PBR (braking reactor) cumulative load factor 12: Frequency setting value (after PID) 13: VIA/II Input value 14: VIB Input value 15: Fixed output 1 (Output current: 100%) 16: Fixed output 2 (Output current: 50%) 17: Fixed output 3 (Other than the output current: 100%)	0		7.20.1
<b>F-77</b>	0671	Maximum numbers of pulse train	pps	1/1	500 - 1600	800		7.20.1
<b>F-91</b>	0672	Inclination characteristic of analog output	-	-	0: Negative inclination (downward slope) 1: Positive inclination (upward slope)	1		7.20.2
<b>F-92</b>	0673	Meter bias	%	1/1	0 - 100	0		7.20.2

● Operation panel parameters

Title	Communication NO.	Function	Unit	Minimum setting unit Panel/Communication	Adjustment range	Default setting	User setting	Reference
<b>H-00</b>	0700	Prohibition of change of parameter settings	-	-	0: Permitted 1: Prohibited	0		7.21.1

Title	Communication NO.	Function	Unit	Minimum setting unit Panel/Communication	Adjustment range	Default setting	User setting	Reference
<b>H-01</b>	0701	Unit selection	-	-	0: % 1: A (ampere)/V (volt)	0		7.21.2
<b>H-02</b>	0702	Free unit selection	Time s	0.01/0.01	0.00: Free unit display disabled (display of frequency) 0.01-200.0	0.00		7.21.3
<b>H-05</b>	0703	Inclination characteristic of free unit display	-	-	0: Negative inclination (downward slope) 1: Positive inclination (upward slope)	1		
<b>H-06</b>	0704	Free unit display bias	Hz	0.01/0.01	0.00 - <b>U-09</b>	0.00		
<b>H-07</b>	0705	Free step 1 (pressing a panel key once)	Hz	0.01/0.01	0.00: Disabled 0.00 - <b>U-09</b>	0.00		7.21.4
<b>H-08</b>	0706	Free step 2 (panel display)	-	1/1	0: Disabled 1-255	0		
<b>H-10</b>	0707	Standard monitor display selection	-	-	0: Operation frequency (Hz/free unit) 1: Frequency command (Hz/free unit) 2: Output current (%/A) 3: Inverter rated current (A) 4: Inverter load factor (%) 5: Output power (%) 6: Frequency command after PID control (Hz/free unit) 7: Optional item specified from an external control unit	0		7.21.5
<b>H-19</b>	0708	Canceling of operation command when standby terminal (ST) is turned off	-	-	0: Operation command canceled(cleared) 1: Operation command retained	1		7.21.6
<b>H-21</b>	0709	Panel stop pattern	-	-	0: Slowdown stop 1: Coast stop	0		7.21.7
<b>H-30</b>	0710	Prohibition of frequency setting on the operation panel	-	-	0: Permitted 1: Prohibited	0		7.21.1
<b>H-33</b>	0711	Panel operation prohibition (RUN/STOP keys)	-	-	0: Permitted 1: Prohibited	0		

Title	Communication NO.	Function	Unit	Minimum setting unit Panel/Communication	Adjustment range	Default setting	User setting	Reference
<b>H-34</b>	0712	Prohibition of panel emergency stop operation	-	-	0: Permitted 1: Prohibited	0		7.21.1
<b>H-35</b>	0713	Prohibition of panel reset operation	-	-	0: Permitted 1: Prohibited	0		
<b>H-36</b>	0714	Prohibition of change of <b>U-01</b> / <b>U-02</b> during operation	-	-	0: Permitted 1: Prohibited	1		

● Communication parameters

Title	Communication NO.	Function	Unit	Minimum setting unit Panel/Communication	Adjustment range	Default setting	User setting	Reference
<b>L-00</b>	0800	Communication rate	-	-	0: 1200bps 1: 2400bps 2: 4800bps 3: 9600bps 4: 19200bps	3		7.22
<b>L-01</b>	0801	Parity	-	-	0: NON (No parity) 1: EVEN (Even parity) 2: ODD (Odd parity)	1		
<b>L-02</b>	0802	Inverter number	-	1/1	0 - 255	0		
<b>L-03</b>	0803	Communication error trip time	s	1/1	0: (disabled) 1-100	0		
<b>L-05</b>	0804	Communication waiting time	s	0.01/0.01	0.00 - 2.00	0.00		
<b>L-06</b>	0805	Setting of master and slave for communication between inverters	-	-	0: Slave (0 Hz command issued in case the master inverter fails) 1: Slave (Operation continued in case the master inverter fails) 2: Slave (Emergency stop tripping in case the master inverter fails) 3: Master (transmission of frequency commands) 4: Master (transmission of output frequency signals)	0		

Title	Communication NO.	Function	Unit	Minimum setting unit Panel/Communication	Adjustment range	Default setting	User setting	Reference
L-11	0806	Communication command point 1 setting	%	1/1	0 - 100	0		7.5.2 7.22.1
L-12	0807	Communication command point 1 frequency	Hz	0.1/0.01	0.0 - 500.0	0.0		
L-13	0808	Communication command point 2 setting	%	1/1	0 - 100	100		
L-14	0809	Communication command point 2 frequency	Hz	0.1/0.01	0.0 - 500.0	50.0		
L-29	0810	Selection of communication protocol	-	-	0: Reverse 1: Modbus RTU protocol	1		7.22
L-70	0811	Block write data 1	-	-	0: No selection 1: Command information 1 2: Command information 2	0		
L-71	0812	Block write data 2	-	-	3: Frequency command 4: Output data on the terminal board 5: Analog output for communications	0		
L-75	0813	Block read data 1	-	-	0: No selection 1: Status information 2: Output frequency	0		
L-76	0814	Block read data 2	-	-	3: Output current 4: Output voltage 5: Alarm information	0		
L-77	0815	Block read data 3	-	-	6: PID feedback value 7: Input terminal board monitor	0		
L-78	0816	Block read data 4	-	-	8: Output terminal board monitor 9: VIA terminal board monitor	0		
L-79	0817	Block read data 5	-	-	10: VIB terminal board monitor	0		
L-80	0818	Free notes	-	1/1	0 - 65535	0		
L-90	0819	Parameter for option 1	-	1/1	0 - 65535	0		
L-91	0820	Parameter for option 2	-	1/1	0 - 65535	0		

Title	Communication NO.	Function	Unit	Minimum setting unit Panel/Communication	Adjustment range	Default setting	User setting	Reference
<b>L-92</b>	0821	Parameter for option 3	-	1/1	0 - 65535	0		7.23
<b>L-93</b>	0822	Parameter for option 4	-	1/1	0 - 65535	0		
<b>L-94</b>	0823	Parameter for option 5	-	1/1	0 - 65535	0		

● PM motor parameters

Title	Communication NO.	Function	Unit	Minimum setting unit Panel/Communication	Adjustment range	Default setting	User setting	Reference
<b>P-10</b>	0910	Step-out detection current level	% (A)	1/1	10 - 150	100		7.24
<b>P-11</b>	0911	Step-out detection time	s	1/1	0.0: No detection 0.1-25.0	0.0		

■ Default settings by inverter rating

Inverter type	Torque boost value 1/2	Dynamic braking resistance	Dynamic braking resistor capacity	Automatic torque boost value	Motor rated current	Motor no-load current	Motor adjustment coefficient	Over-voltage stall protection level
	<b>U-15/R-72</b> (%)	<b>ε-08</b> (Ω)(Note)	<b>ε-09</b> (kW)	<b>d-02</b> (%)	<b>d-15</b> (A)	<b>d-16</b> (%)	<b>d-94</b>	<b>F-26</b> (%)
1L	6.0	200.0	0.12	5.8	3.4	60	80	134
2L	6.0	75.0	0.12	4.3	6.2	55	70	134
3L	5.0	75.0	0.12	4.1	8.9	52	70	134
5L	5.0	40.0	0.12	3.4	14.8	48	70	134
7L	4.0	20.0	0.24	3.0	21.0	46	70	134
10L	3.0	15.0	0.44	2.5	28.2	43	70	134
15L	2.0	10.0	0.66	2.3	40.6	41	60	134
20L	2.0	7.5	0.88	2.0	54.6	38	50	134
25L								
30L								
40L								
1H	6.0	200.0	0.12	5.8	1.7	60	80	140
2H	6.0	200.0	0.12	4.3	3.1	55	70	140
3H	5.0	200.0	0.12	4.1	4.5	52	70	140
5H	5.0	160.0	0.12	3.4	7.4	48	70	140
7H	4.0	80.0	0.24	2.6	10.5	46	70	140
10H	3.0	60.0	0.44	2.3	14.1	43	70	140
15H	2.0	40.0	0.66	2.2	20.3	41	60	140
20H	2.0	30.0	0.88	1.9	27.3	38	50	140
25H								
30H								
40H								

Note: Be sure to set **ε-08** (Dynamic braking resistance) at the resistance of the dynamic braking resistor connected.

## ■ Table of input terminal functions 1

Function No.	Code	Function	Action
0	-	No function is assigned	Disabled
1	ST	Standby terminal	ON: Ready for operation OFF: Coast stop (gate off)
2	F	Forward run command	ON: Forward run    OFF: Slowdown stop
3	R	Reverse run command	ON: Reverse run    OFF: Slowdown stop
4	JOG	Jog run mode	ON: Jog run, OFF: Jog run canceled
5	AD2	Acceleration/deceleration 2 pattern selection	ON: Acceleration/deceleration 2 OFF: Acceleration/deceleration 1 or 3
6	SS1	Preset-speed command 1	Selection of 15-speed with SS1 to SS4 (4 bits)
7	SS2	Preset-speed command 2	
8	SS3	Preset-speed command 3	
9	SS4	Preset-speed command 4	
10	RES	Reset command	ON: Acceptance of reset command ON → OFF: Trip reset
11	EXT	Trip stop command from external input device	ON: <b>ES&amp;P</b> Trip stop
12	CFMOD	Switching of command mode and frequency setting mode	ON: Forced switching from command mode to terminal input mode, forced switching from frequency setting mode to the mode commanded between <b>U-02</b> and <b>U-07</b> . (If <b>b-00 = 0</b> )
13	DB	DC braking command	ON: DC braking
14	PID	PID control prohibited	ON: PID control prohibited OFF: PID control permitted
15	PWENE	Permission of parameter editing	ON: Parameter editing permitted OFF: Parameter editing prohibited (If <b>H-00 = 1</b> )
16	ST+RES	Combination of standby and reset commands	ON: Simultaneous input from ST and RES
17	ST+CFMOD	Combination of standby and command/frequency setting mode switching	ON: Simultaneous input from ST and CFMOD
18	F+JOG	Combination of forward run and jog run	ON: Simultaneous input from F and JOG
19	R+JOG	Combination of reverse run and jog run	ON: Simultaneous input from R and JOG
20	F+AD2	Combination of forward run and acceleration/deceleration 2	ON: Simultaneous input from F and AD2
21	R+AD2	Combination of reverse run and acceleration/deceleration 2	ON: Simultaneous input from R and AD2
22	F+SS1	Combination of forward run and preset-speed command 1	ON: Simultaneous input from F and SS1
23	R+SS1	Combination of reverse run and preset-speed command 1	ON: Simultaneous input from R and SS1
24	F+SS2	Combination of forward run and preset-speed command 2	ON: Simultaneous input from F and SS2
25	R+SS2	Combination of reverse run and preset-speed command 2	ON: Simultaneous input from R and SS2

Function No.	Code	Function	Action
26	F+SS3	Combination of forward run and preset-speed command 3	ON: Simultaneous input from F and SS3
27	R+SS3	Combination of reverse run and preset-speed command 3	ON: Simultaneous input from R and SS3
28	F+SS4	Combination of forward run and preset-speed command 4	ON: Simultaneous input from F and SS4
29	R+SS4	Combination of reverse run and preset-speed command 4	ON: Simultaneous input from R and SS4
30	F+SS1+AD2	Combination of forward run, preset-speed command 1 and acceleration/deceleration 2	ON: Simultaneous input from F, SS1 and AD2
31	R+SS1+AD2	Combination of reverse run, preset-speed command 1 and acceleration/deceleration 2	ON: Simultaneous input from R, SS1 and AD2
32	F+SS2+AD2	Combination of forward run, preset-speed command 2 and acceleration/deceleration 2	ON: Simultaneous input from F, SS2 and AD2
33	R+SS2+AD2	Combination of reverse run, preset-speed command 2 and acceleration/deceleration 2	ON: Simultaneous input from R, SS2 and AD2

## ■ Table of input terminal functions 2

Function No.	Code	Function	Action
34	F+SS3+AD2	Combination of forward run, preset-speed command 3 and acceleration/deceleration 2	ON: Simultaneous input from F, SS3 and AD2
35	R+SS3+AD2	Combination of reverse run, preset-speed command 3 and acceleration/deceleration 2	ON: Simultaneous input from R, SS3 and AD2
36	F+SS4+AD2	Combination of forward run, preset-speed command 4 and acceleration/deceleration 2	ON: Simultaneous input from F, SS4 and AD2
37	R+SS4+AD2	Combination of reverse run, preset-speed command 4 and acceleration/deceleration 2	ON: Simultaneous input from R, SS4 and AD2
38	FCHG	Frequency command forced switching	ON: <b>b-07</b> (If <b>b-00=0</b> ) OFF: <b>U-02</b>
39	VF2	No.2 Switching of V/F setting	ON: No.2 V/F setting ( <b>U-14=0, A-70, A-71, A-72, A-73</b> ) OFF: No.1 V/F setting (Set value of <b>U-14, U-12, U-13, U-15, U-16</b> )
40	MOT2	No.2 motor switching ( VF2 + AD2 + OCS2 )	ON: No.2 motor ( <b>U-14=0, A-70, A-71, A-72, A-73, A-85, E-00, E-01, E-03</b> ) OFF: No.1 motor (Set value of <b>U-14, U-12, U-13, U-15, U-16, U-07, U-08, E-02, F-01</b> )
41	UP	Frequency UP signal input from external contacts	ON: Increase in frequency
42	DOWN	Frequency DOWN signal input from external contacts	ON: Reduction in frequency

Function No.	Code	Function	Action
43	CLR	Frequency UP/DOWN cancellation signal input from external contacts	OFF→ON: Resetting of UP/DOWN frequency by means of external contacts
44	CLR+RES	Combination of frequency UP/DOWN cancellation and reset by means of external contacts	ON: Simultaneous input from CLR and RES
45	EXTN	Inversion of trip stop command from external device	OFF: <del>ESTP</del> Trip stop
46	OH	Thermal trip stop signal input from external device	ON: <del>OH-2</del> Trip stop
47	OHN	Inversion of thermal trip stop command from external device	OFF: <del>OH-2</del> Trip stop
48	SC/LC	Forced switching from remote to local control	Enabled when remote control is exercised ON: Local control (setting of <del>U-01</del> , <del>U-02</del> and <del>b-01</del> ) OFF: Remote control
49	HD	Operation holding (stop of 3-wire operation)	ON: F (forward run)/R: (reverse run) held, 3-wire operation OFF: Slowdown stop
50	CMTP	Forced switching of command mode and terminal board command	ON: Terminal board operation OFF: Setting of <del>U-01</del>
51	CKWH	Display cancellation of the cumulative power amount (kWh)	ON: Monitor display cancellation of the cumulative power amount (kWh)
52	FORCE	Forced operation (factory configuration required)	ON: Forced operation mode in which operation is not stopped in the event of the occurrence of a soft fault (preset speed operation frequency 15) To use this function, the inverter needs to be so configured at the factory. OFF: Normal operation
53	FIRE	Fire-speed control	ON: Fire-speed operation (preset speed operation frequency 15) OFF: Normal operation

Note. When function 1, 10-12, 15-17, 38, 41-45 or 48 is assigned to an input terminal board, the input terminal board is enabled even if the parameter command mode selection ~~U-01~~ is set at 1 (panel).

### ■ Table of input terminal functions 3

Function No.	Code	Function	Action
54	STN	Coast stop (gate off)	ON: Coast stop (gate off)
55	RESN	Inversion of RES	ON: Acceptance of reset command OFF→ ON: Trip reset
56	F+ST	Combination of forward run and standby	ON: Simultaneous input from F and ST
57	R+ST	Combination of reverse run and standby	ON: Simultaneous input from R and ST
58	AD3	Acceleration/deceleration 3 selection	ON: Acceleration/deceleration 3 OFF: Acceleration/deceleration 1 or 2
59	F+AD3	Combination of forward run and acceleration/deceleration 3	ON: Simultaneous input from F and AD3
60	R+AD3	Combination of reverse run and acceleration/deceleration 3	ON: Simultaneous input from R and AD3

Function No.	Code	Function	Action
61	OCS2	Forced switching of stall prevention level 2	ON: Enabled at the value of <b>A-85</b> OFF: Enabled at the value of <b>F-01</b>
62	HDRY	Holding of RY-RC terminal output	ON: Once turned on, RY-RC are held on. OFF: The status of RY-RC changes in real time according to conditions.
63	HDOUT	Holding of OUT-NO terminal output	ON: Once turned on, OUT-NO are held on. OFF: The status of OUT-NO changes in real time according to conditions.
64	PRUN	Cancellation (clearing) of operation command from panel	0: Operation command canceled (cleared) 1: Operation command retained
65	ICLR	PID control integral value clear	ON: PID control integral value always zero OFF: PID control permitted

### ■ Table of output terminal functions 1

Function No.	Code	Function	Action
	LL	Frequency lower limit	ON: The output frequency is above the <b>U-11</b> set value. OFF: The output frequency is equal to or less than the <b>U-11</b> set value.
1	LLN	Inversion of frequency lower limit	Inversion of LL setting
2	UL	Frequency upper limit	ON: Output frequency is equal to or higher than <b>U-10</b> value. OFF: Output frequency is lower than <b>U-10</b> value.
3	ULN	Inversion of frequency upper limit	Inversion of UL setting
4	LOW	Low-speed detection signal	ON: Output frequency is equal to or higher than <b>A-00</b> value. OFF: Output frequency is lower than <b>A-00</b> value.
5	LOWN	Inversion of low-speed detection signal	Inversion of LOW setting
6	RCH	Designated frequency attainment signal (completion of acceleration/deceleration)	ON: The output frequency is equal to or less than the specified frequency $\pm$ frequency set with <b>A-02</b> . OFF: The output frequency is above the specified frequency $\pm$ frequency set with <b>A-02</b> .
7	RCHN	Inversion of designated frequency attainment signal (inversion of completion of acceleration/deceleration)	Inversion of RCH setting
8	RCHF	Set frequency attainment signal	ON: The output frequency is equal to or less than the frequency set with <b>A-01</b> $\pm$ <b>A-02</b> . OFF: The output frequency is above the frequency set with <b>A-01</b> $\pm$ <b>A-02</b> .
9	RCHFN	Inversion of set frequency attainment signal	Inversion of RCHF setting
10	FL	Failure signal (trip output)	ON: When inverter is tripped OFF: When inverter is not tripped
11	FLN	Inversion of failure signal (inversion of trip output)	Inversion of FL setting

## ■ Table of output terminal functions 2

Function No.	Code	Function	Action
12	OT	Over-torque detection	ON: Torque current is equal to or larger than set value and longer than <b>F-18</b> set time. OFF: The torque current is equal to or less than ( <b>F-16</b> set value - <b>F-19</b> set value).
13	OTN	Inversion of over-torque detection	Inversion of OT
14	RUN	Start/Stop	ON: When operation frequency is output or during ( <b>db</b> ) OFF: Operation stopped
15	RUNN	Inversion of RUN/STOP	Inversion of RUN setting
16	POL	OL pre-alarm	ON: 50% or more of calculated value of overload protection level OFF: Less than 50% of calculated value of overload protection level
17	POLN	Inversion of OL pre-alarm	Inversion of POL setting
18	POHR	Braking resistor overload pre-alarm	ON: 50% or more of calculated value of <b>C-08</b> set overload protection level OFF: Less than 50% of calculated value of <b>C-08</b> set overload protection level
19	POHRN	Inversion of braking resistor overload pre-alarm	Inversion of RCHR setting
20	POT	Over-torque detection pre-alarm	ON: Torque current is equal to or larger than 70% of <b>F-16</b> set value. OFF: The torque current is below ( <b>F-16</b> set value x 70% - <b>F-19</b> set value).
21	POTN	Inversion of over-torque detection pre-alarm	Inversion of POT setting
22	PAL	Pre-alarm	One of the following is turned on: ON POL, POHR, POT, MOFF, UC, OT, LL stop, COT, and momentary power failure slowdown stop. or <b>C,P,Or,H</b> issues an alarm All the following are turned off: OFF POL, POHR, POT, MOFF, UC, OT, LL stop, COT, and momentary power failure slowdown stop. or <b>C,P,Or,H</b> issues no alarm
23	PALN	Inversion of pre-alarm	Inversion of PAL setting
24	UC	Small-current detection	ON: The output current is equal to or less than <b>F-11</b> set value for <b>F-12</b> set time. OFF: The output current is equal to or larger than <b>F-11</b> set value + 10%.
25	UCN	Inversion of small-current detection	Inversion of UC setting
26	HFL	Significant failure	ON: ( <b>OC-R,OC-L,OL-1,ESLP,CPFS,ALnE,PF-0,CPF3,CPF4,CPF0,CE-1,OH-2,Uu-1,GF-1,CPF9,OPE2,Or,PF-1</b> ) OFF: Failure other than the above
27	HFLN	Inversion of significant failure	Inversion of HFL setting
28	LFL	Insignificant failure	ON: ( <b>OC-1-3,OU-1-3,OH-1,OL-1-2,OL-r</b> ) OFF: Failure other than the above
29	LFLN	Inversion of insignificant failure	Inversion of LFL setting

Function No.	Code	Function	Action
30	RDY1	Ready for operation (including ST/RUN)	ON: Ready for operation (ST and RUN are also ON) OFF: Others
31	RDY1N	Inversion of ready for operation (including ST/RUN)	Inversion of RDY1 setting
32	RDY2	Ready for operation (excluding ST/RUN)	ON: Ready for operation (ST and RUN are not ON) OFF: Others
33	RDY2N	Inversion of ready for operation (excluding ST/RUN)	Inversion of RDY2
34	FCVIB	Frequency VIB selection	ON: VIB selected as frequency command OFF: Terminal other than VIB selected as frequency command

### ■ Table of output terminal functions 3

Function No.	Code	Function	Action
35	FCVIBN	Inversion of frequency VIB selection	Inversion of FCVIB
36	FLR	Fault signal (put out also at the time of a retry)	ON: When inverter trips or retries OFF: When inverter does not trip or retry
37	FLRN	Inversion of failure signal (put out also at the time of a retry)	Inversion of FLR
38	OUT0	Specified data output 1	ON: Specified data from remote control FA50: BIT0= 1 OFF: Specified data from remote control FA50: BIT0= 0
39	OUT0N	Inversion of specified data output 1	Inversion of OUT0 setting
40	OUT1	Specified data output 2	ON: Specified data from remote control FA50: BIT1= 1 OFF: Specified data from remote control FA50: BIT1= 0
41	OUT1N	Inversion of specified data output 2	Inversion of OUT1 setting
42	COT	Cumulative operation time alarm	ON: Cumulative operation time is equal to or longer than <b>F-21</b> OFF: Cumulative operation time is shorter than <b>F-21</b>
43	COTN	Inversion of cumulative operation time alarm	Inversion of COT
44	LTA	Parts replacement alarm	ON: Calculation for parts replacement time is equal to or longer than the preset time ON: Calculation for parts replacement time is shorter than the preset time
45	LTAN	Inversion of replacement alarm	Inversion of LTA
46	BR	Braking sequence output	ON: Braking retention signal OFF: Braking release signal
47	BRN	Inversion of braking sequence output	Inversion of BR
48	LI1	F terminal input signal	ON: The signal input to F terminal is ON OFF: The signal input to F terminal is OFF
49	LI1N	Inversion of F terminal input signal	Inversion of LI1
50	LI2	R terminal input signal	ON: The signal input to R terminal is ON OFF: The signal input to R terminal is OFF

Function No.	Code	Function	Action
51	LI2N	Inversion of R terminal input signal	Inversion of LI2
52	PIDF	Signal in accordance of frequency command	ON: Frequency commanded by <b>U-02</b> or <b>b-07</b> and that by VIA show the same value. OFF: Frequency commanded by <b>U-02</b> or <b>b-07</b> and that by VIA show different values.
53	PIDFN	Inversion of signal in accordance of frequency command	Inversion of PIDF setting
54	MOFF	Undervoltage detection	ON: Undervoltage detected OFF: Other than undervoltage
55	MOFFN	Inversion of undervoltage detection	Inversion of MOFF
56-253	Disabled	Invalid settings, always OFF (ignored)	Invalid settings, always OFF (ignored)
254	AOFF	Always OFF	Always OFF
255	AON	Always ON	Always ON

## 6. Basic parameters

Before you operate the inverter, the parameters that you must first program are the basic parameters.

### 6.1 Setting acceleration / deceleration time

#### CU-1: Automatic acceleration / deceleration

U-07: Acceleration time 1

U-08: Deceleration time 1

#### ■ Function

- 1) For acceleration time 1 **U-07** programs the time that it takes for the inverter output frequency to go from 0Hz to maximum frequency **U-09**.
- 2) For deceleration time 1 **U-08** programs the time that it takes for the inverter output frequency to get from maximum frequency **U-09** to 0Hz.

#### 6.1.1 Automatic acceleration/deceleration

This automatically adjusts acceleration and deceleration time in line with load size.

**CU-1** = 1

- \* Adjusts the acceleration/deceleration time automatically within the range of 1/8 to 8 times as long as the time set with the **U-07** or **U-08**, depending on the current rating of the inverter.

**CU-1** = 2

- \* Automatically adjusts speed during acceleration only. During deceleration, speed is not adjusted automatically but reduced at the rate set with **U-08**.

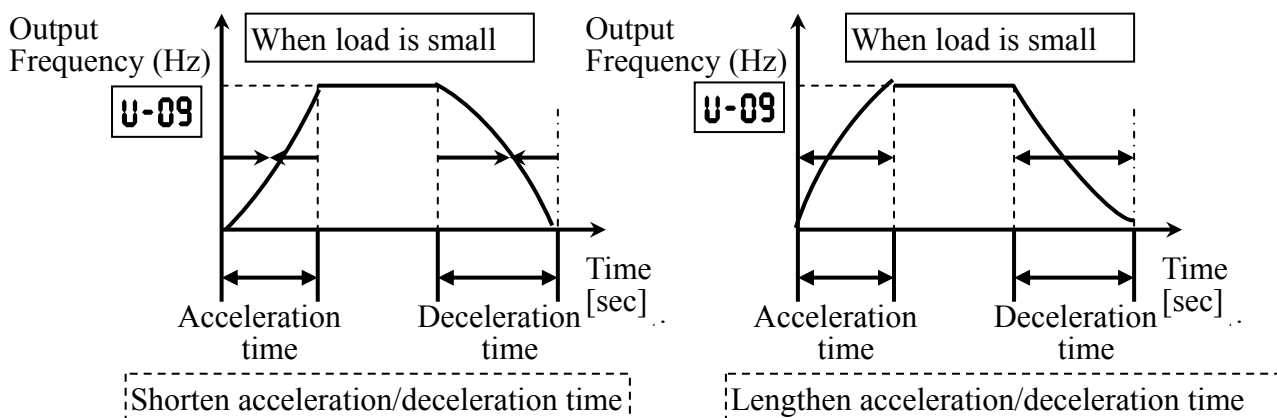









Set **CU-H** (automatic acceleration / deceleration ) to 1 or 2

[Parameter setting]

Title	Function	Adjustment range	Default setting
<b>CU-1</b>	Automatic acceleration/deceleration	0: Disabled (manual) 1: Automatic 2: Automatic (only at acceleration)	0

- ☆ When automatically setting acceleration/deceleration time, always change the acceleration / deceleration time so that it conforms to the load. The acceleration / deceleration time changes constantly with load fluctuations. For inverters that requires a fixed acceleration/deceleration time, use the manual settings ( **U-07, U-08** ).
- ☆ Setting acceleration/deceleration time ( **U-07, U-08** ) in conformance with mean load allows optimum setting that conforms to further changes in load.
- ☆ Use this parameter after actually connecting the motor.
- ☆ When the inverter is used with a load that fluctuates considerably, it may fail to adjust the acceleration or deceleration time in time, and therefore may be tripped.

[Methods of setting automatic acceleration/deceleration]

Key operated	LED display	Operation
	<b>00</b>	Displays the operation frequency. (When standard monitor display selection <b>H-10</b> is set to <b>0</b> [Operation frequency])
	<b>CU-H</b>	The first basic parameter “ <b>CU-H</b> ” (history function) is displayed.
	<b>CU-1</b>	Press the  key to change the parameter to <b>CU-1</b> .
	<b>0</b>	Pressing the  key allows the reading of parameter setting
	<b>1</b>	Press the  key to change the parameter to <b>1</b> or <b>2</b> .
	<b>1 ⇔ CU-1</b>	Press the  key to save the changed parameter. <b>CU-1</b> and the parameter are displayed alternately.

### 6.1.2 Manually setting acceleration/deceleration time

Set acceleration time from 0 (Hz) operation frequency to maximum frequency **U-09** and deceleration time as the time when operation frequency goes from maximum frequency **U-09** to 0 (Hz).

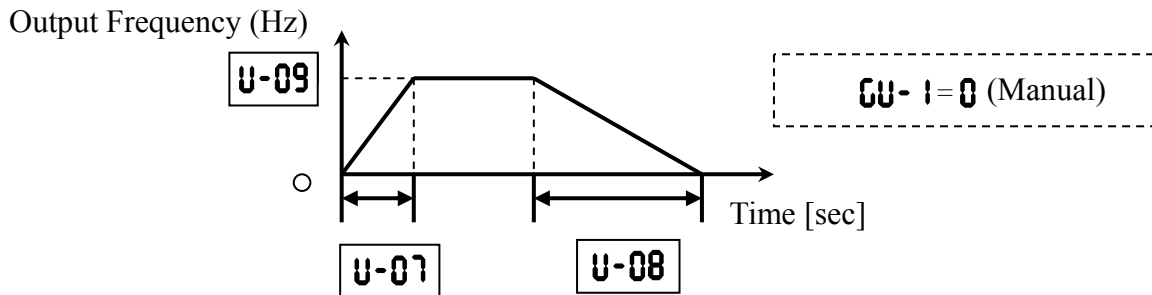

[Parameter setting]

Title	Function	Adjustment range	Default setting
<b>U-07</b>	Acceleration time 1	0.0-3200 sec.	10.0
<b>U-08</b>	Deceleration time 1	0.0-3200 sec.	10.0

Note: When the acceleration/deceleration time is set at 0.0 seconds, the inverter speed increases or reduces speed within 0.05 seconds.

- ☆ If the programmed value is shorter than the optimum acceleration/deceleration time determined by load conditions, overcurrent stall or overvoltage stall function may make the acceleration/deceleration time longer than the programmed time. If an even shorter acceleration/deceleration time is programmed, there may be an overcurrent trip or overvoltage trip for inverter protection. (For further details, see 9.1 Page 9-1)

## 6.2 Increasing starting torque

### **CU-2 : Torque boost setting macro function**

#### ■ Function

Simultaneously switches inverter output (V/F) control and programs motor constants automatically (On-line automatic-tuning function) to improve torque generated by the motor. This parameter integrates the setting of special V/F control selection such as vector control.

Title	Function	Adjustment range	Default setting
<b>CU-2</b>	Torque boost setting macro function	0: Disabled 1: Automatic 2: Automatic torque boost + auto-tuning 3: Energy saving + auto-tuning	0

Note: Parameter displays on the right always return to 0 after setting. The previous setting is displayed on the left.

Ex.

#### 1) Increasing torque automatically according to the load

Set **CU-2** is set to **1** (automatic torque boost + auto-tuning)

When **CU-2** is set to **1** (automatic torque boost + auto-tuning), the inverter keeps track of the load current in any speed range and automatically adjusts the output voltage to ensure

enough torque and stable operation.

Note 1: The same characteristic can be obtained by setting the V/F control mode selection parameter **U-14** to **2** (automatic torque boost control) and the auto-tuning parameter **d-00** to **2** (auto-tuning). ⇒ See 6.12 (Page 6-25)

Note 2 : Setting **CU-2** to **1** automatically programs **U-14** to **2** .

Note 3 : The accuracy of auto-tuning can be increased by specifying the rated current of the driven motor, using the motor rated current setting parameter **d-15** .

## 2) When using vector control (increasing starting torque and high-precision operations)

Set **CU-2** to **2** (vector control + auto-tuning)

Setting **CU-2** to **2** (vector control + auto-tuning) provides high starting torque bringing out the maximum in motor characteristics from the low-speed range. This suppresses changes in motor speed caused by fluctuations in load to provide high precision operation. This is an optimum feature for elevators and other load transporting machinery.

Note 1: The same characteristic can be obtained by setting the V/F control mode selection parameter **U-14** to **3** (vector control) and the auto-tuning parameter **d-00** to **2** ( auto-tuning). ⇒ See 6.12 (Page 6-25)

Note 2 : Setting **CU-2** to **2** automatically programs **U-14** to **3** .

## 3) Energy-saving operation



**CU-2** is set to **3** (energy saving + auto-tuning)







When **CU-2** is set to **3** (energy saving + auto-tuning), the inverter always passes a current appropriate to the load for energy saving.

Note 1: The same characteristic can be obtained by setting the V/F control mode selection parameter **U-14** to **4** (automatic energy saving) and the auto-tuning parameter **d-00** to **2** ( auto-tuning).

Note 2 : When **CU-2** is set to **3**, **U-14** is automatically set to **4** .

[Example of parameter setting]

Key operated	LED display	Operation
	<b>00</b>	Displays the operation frequency.(Perform during operation stopped.) (When standard monitor display selection <b>H-10</b> is set to <b>0</b> [Operation frequency])
	<b>CU-H</b>	The first basic parameter “ <b>CU-H</b> ” (history function) is displayed.
	<b>CU-2</b>	Press the  key to change the parameter to <b>CU-2</b> .

Key operated	LED display	Operation
	0 0	Pressing the  key allows the reading of parameter setting.
	0 3	Change the parameter setting to <b>3</b> (energy saving + auto-tuning), using the  key .
	0 3 = CU-2	Press the  key to save the changed parameter. <b>CU-2</b> and the parameter are displayed alternately.

If vector control cannot be programmed---

First read the precautions about vector control in 6.11, 8.

- 1) If the desired torque cannot be obtained ⇒ see 7.17.1 (Page 7-52)
- 2) If auto-tuning error “**Rt n E**” appears ⇒ see 7.17.1 (Page 7-52)

- **CU-2** ( Torque boost setting macro function ) and **U- 14** (V/F control mode selection)  
Automatic torque boost is the parameter for setting V/F control mode selection ( **U- 14** ) and auto-tuning ( **d-00** ) together. That is why all parameters related to change automatically when **CU-2** is changed.

<b>CU-2</b>		Automatically programmed parameters	
		<b>U- 14</b>	<b>d-00</b>
<b>0</b>	Displays <b>0</b> after resetting	-	Check the programmed value of <b>U- 14</b> . -
<b>1</b>	Automatic torque boost + auto-tuning	<b>2</b>	Automatic torque boost Executed ( <b>0</b> after execution)
<b>2</b>	Vector control + auto-tuning	<b>3</b>	Sensorless vector control Executed ( <b>0</b> after execution)
<b>3</b>	Energy saving + auto-tuning	<b>4</b>	Energy saving Executed ( <b>0</b> after execution)

#### 4) Increasing torque manually ( V/F constant control )

This is the setting of constant torque characteristics that are suited for such things as conveyors. It can also be used to manually increase starting torque.

If V/F constant control is programmed after changing **CU-2** ,

Set V/F control mode selection **U- 14 = 0** ( V/F constant).

⇒ see 6.11 (Page 6-18)

Note 1 : To further increase torque, increase the torque boost amount **1U- 15** .

How to set the torque boost amount **1U- 15** ⇒ see 6.12 (Page 6-25)

Note 2 : V/F control selection **U- 14 = 1** ( variable torque) is an effective setting for load such as fans and pumps. ⇒ see 6.11 (Page 6-18)

## 6.3 Specifying an operation mode, using parameters

### **CU-4 : Parameter setting macro function**

#### ■ Function

Automatically programs all parameters ( parameters described below) related to the functions by selecting the inverter's operating method.

The major functions can be programmed simply.

[Parameter setting]

Title	Function	Adjustment range	Default setting
<b>CU-4</b>	Parameter setting macro function	0: Disabled 1: Coast stop 2: 3-wire operation 3: External input UP/DOWN setting 4: 4-20mA current input operation	0

Note : When this parameter is invoked after it has been set, **0** is always displayed (on the right side ).

The number on the left side refers to the number specified previously.

Example 1 0

Automatically programmed functions and parameter set values

Relational parameter	Default setting value	1: Coast stop	2: -wire operation	3: External input UP/DOWN setting	4: 4-20mA current input operation
<b>U-01</b>	1: Operation panel	0: Terminal board	0: Terminal board	0: Terminal board	0: Terminal board
<b>U-02</b>	0: Potentiometer	0: Potentiometer	0: Potentiometer	5: UP/DOWN from external contact	1: VIA
<b>R-10</b> (Always)	1: ST	0: Disabled	1: ST	1: ST	1: ST
<b>R-11</b> (F)	2:F	2:F	2:F	2:F	2:F
<b>R-12</b> (R)	3:R	3:	3:R	3:R	3:R
<b>R-13</b> (RES)	10: RES	10: RES	10: RES	10: RES	10: RES
<b>R-14</b> (S1)	6: SS1	6: SS1	6: SS1	41:UP	6: SS1
<b>R-15</b> (S2)	7: SS2	7: SS2	7: SS2	42: DOWN	7: SS2
<b>R-16</b> (S3)	8: SS3	1: ST	49: HD	43: CLR	38: FCHG
<b>b-01</b>	0 (%)	-	-	-	20 (%)

Note) See Page 5-23 for input terminal functions.

Disabled (**CU-4=0**)

The parameter does nothing. Even if set to **0**, **CU-4** will not return the setting you made to its factory default.

Coast stop (**CU-4 = 1**)

Setting for coast stopping. In sink logic mode, closing the circuit between the S3 and CC terminals places the inverter in standby mode and opening the circuit places it in coast stop mode, because ST (standby signal) is assigned to the S3 terminal.

Refer to 3.1.1 (3) (Page 3-5) and 7.3.1 (Page 7-7) for details

3-wire operation (**CU-4 = 2**)

Can be operated by a momentary push-button. HD (operation holding) is assigned to the terminal S3. A self-holding of operations is made in the inverter by connecting the stop switch (b-contact) to the S3 terminal and connecting the running switch (a-contact) to the F terminal or the R terminal.

☆ Three-wire operation (one-touch operation)

You can carry out operation by simply pressing the ON/OFF button.

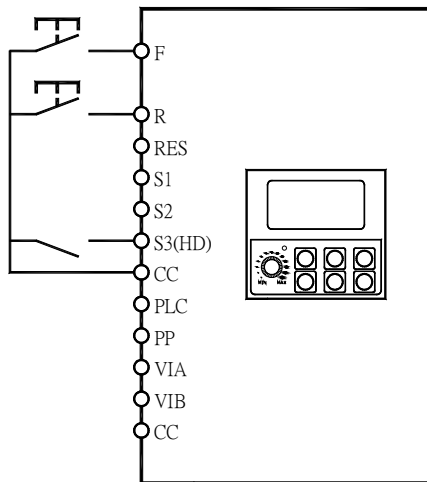

Selecting HD (operation holding) with the input terminal selection parameter  
 Selecting HD (operation holding) using the input terminal selection parameter,  
 and turn HD on to get the inverter ready for operation or turn HD off to stop operation.

Note 1 : To carry out three-wire operation, set **A-10** to **1** (ST) and **U-01** to **0** (terminal board).

To assign HP (operation holding) to input terminal S3, set parameter **A-16** to **49** (operation holding).

Note 2 : Even if each terminal is ON, any command entered through a terminal is ignored when power is turned on (to prevent the load from starting to move unexpectedly). Enable to turn the input terminal on at power on.

Note 3 : When HD is OFF, any attempt to turn on F or R is ignored. When R is ON, you cannot start operation by turning on HD. Even when both R and HD are ON, you cannot start operation by turning on F. To start operation, turn off F and R temporarily, then turn them back on.

Note 4 : If select Jog run command during three-wire operation, inverter stops.

Note 5 : Sending out a RUN signal during DC braking has no effect in stopping DC braking.

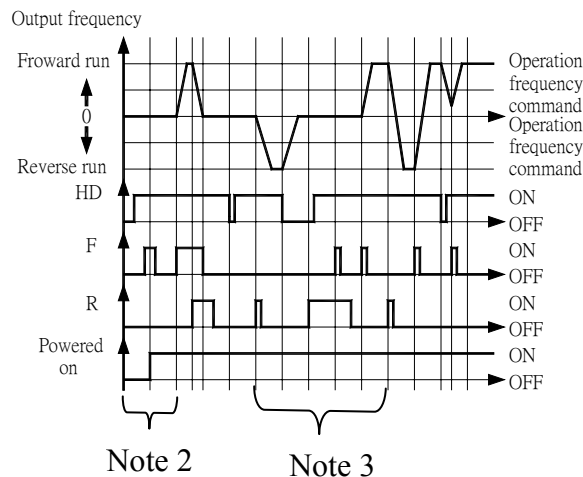

**External input UP / DOWN setting (CU-4 = 3)**

Allows setting of frequency with the input from an external contact. Can be applied to changes of frequencies from several locations.

UP (frequency up signal input from external contact) is assigned to the S1 terminal, and DOWN (frequency down signal input from external contact) are assigned to the S2 and CLR (frequency up/down clear signal input from external contact) are assigned to the S3 terminals respectively. Frequencies can be changed by input to the S1 and S2 terminals.

Refer to 7.5.3 for details.

**4-20 mA current input (CU-4 = 4)**

Used for setting frequencies with 4-20mA current input. Switching between remote control and manual control (different frequency commands) can be made by turning on or off the S3 terminal, because FCHG (forced change of frequency commands) is assigned to the S3 terminal with priority current input.

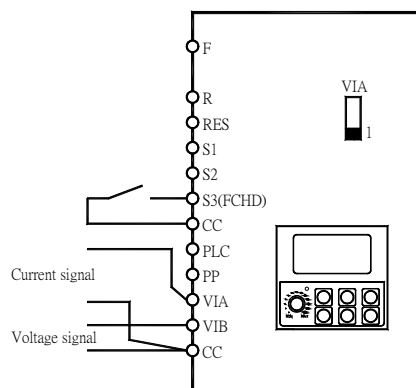

## 6.4 Selection of operation mode

### U-01 : Command mode selection

### U-02 : Frequency setting mode selection 1

#### ■ Function

These parameters are used to specify which input device (operation panel or terminal board) takes priority in entering an operation stop command or a frequency setting command (internal potentiometer, VIA, VIB, operation panel, serial communication device, external contact up/down, VIA+VIB).

#### [Command mode selection]

Title	Function	Adjustment range	Default setting
<b>U-01</b>	Command mode selection	0: Terminal board 1: Operation panel	1

#### Programmed value

**0** : Terminal board operation ON and OFF an external signal Runs and stops operation.

**1** : Operation panel operation Press the  and  keys on the operation panel to start and stop.



\* There are two types of function: the function that conforms to commands selected by **U-01**, and the function that conforms only to commands from the terminal board. See the table of input terminal function selection in Chapter 5.

\* When priority is given to commands from a linked computer or terminal board, they have priority over the setting of **U-01**.

#### [Frequency setting mode selection]

Title	Function	Adjustment range	Default setting
<b>U-02</b>	Frequency setting mode selection 1	0: Built-in potentiometer 1: VIA 2: VIB 3: Operation panel 4: Serial communication 5: UP/DOWN from external contact 6: VIA+VIB (Override)	0

[Programmed value]

- 0**: Potentiometer The internal potentiometer to the inverter is used for setting frequencies. Turning the notches clockwise raises the frequency.
- 1**: VIA input A frequency command is set by means of a signal from an external input device (VIA terminal: 0-10Vdc or 4-20mAdc).
- 2**: VIB input An external signal (VIB terminal: 0-10Vdc) is used to specify a frequency command.
- 3**: Operation panel Press the  key or the  key on either the operation panel or the expansion panel (optional) to set frequency.
- 4**: Communication Frequencies are set by commands from an external control unit.
- 5**: UP / DOWN frequency Terminals are used to specify an up/down frequency command.
- 6**: VIA+VIB (Override) The sum of the values entered through the VIA and VIB terminals is used as a frequency command value.

☆ No matter what value the command mode selection **U-01** and the frequency setting mode selection **U-02** are set to the control input terminal functions described below are always in operative state.

- Reset terminal (default setting: RES, valid only for tripping)
- Standby terminal (when programmed by programmable input terminal functions).
- External input tripping stop terminal command (when so set using the programmable input terminal function)

☆ To make changes in the command mode selection **U-01** and the frequency setting mode selection **U-02**, first stop the inverter temporarily.

(Can be changed while in operation when **H-36** is set to **0**.)

#### ■ Preset-speed operation

**U-01** : Set to **0** (Terminal board).

**U-02** : Valid in all setting values.

## 6.5 Meter setting and adjustment

**U-03 : Meter selection**  
**U-04 : Meter adjustment**

### ■ Function

The signal output from the FM terminal is an analog voltage signal.

For the meter, use either a full-scale 0-1mAdc ammeter or full-scale 0-7.5Vdc (or 10Vdc-1mA) voltmeter. Switching to 0-20mAdc (4-20mAdc) output current can be made by turning the FM slide switch to the I position. When switching to 4-20mAdc current input, make adjustments using **F-91** (analog output gradient) and **F-92** (analog output bias).

[Connected meter selection parameter]

Title	Function	Adjustment range	Supposition output at <b>U-03 = 17</b>	Default setting
<b>U-03</b>	Meter selection	0: Output frequency 1: Output current 2: Set frequency 3: DC voltage 4: Output voltage command value 5: Input power 6: Output power 7: Torque 8: Torque current 9: Motor cumulative load factor 10: Inverter cumulative load factor 11:PBR (braking resistor) cumulative load factor 12: Frequency setting value (after PID) 13: VIA/II Input value 14: VIB Input value 15: Fixed output 1 (Output current: 100%) 16: Fixed output 2 (Output current: 50%) 17: Fixed output 3 (Other than the output current: 100%) 18: Serial communication data 19: For adjustments ( <b>U-04</b> set value is displayed.)	Maximum frequency ( <b>U-09</b> ) - Maximum frequency ( <b>U-09</b> ) 1.5 times of rated voltage 1.5 times of rated voltage 1.85 times of rated power 1.85 times of rated power 2.5 times of rated torque 2.5 times of rated torque Rated load factor Rated load factor Rated load factor Maximum frequency ( <b>U-09</b> ) Maximum input value Maximum input value - - - - -	0
<b>U-04</b>	Meter adjustment	-	-	-

■ Resolution

All FM terminals have a maximum of 1/1000.

■ Example of 4-20mA output adjustment (for details, see 7.20.2 Page 7-75)

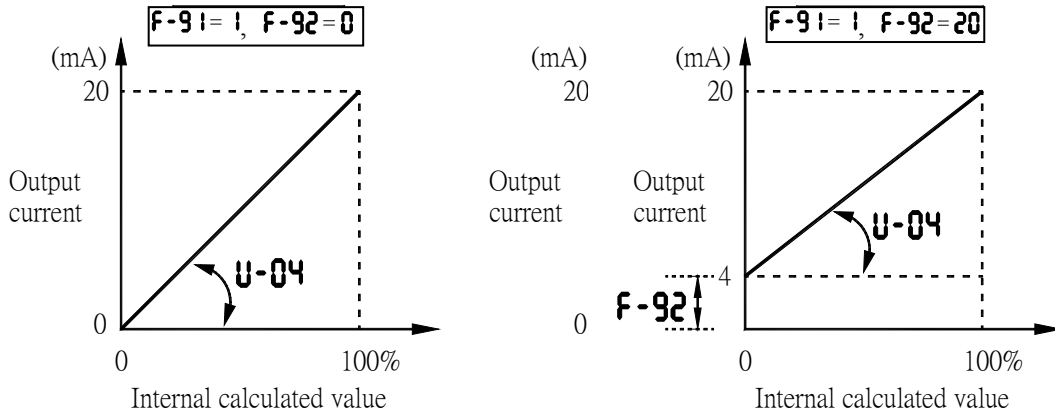

Note 1) When using the FM terminal for current output, be sure that the external load resistance is less than 750Ω.

Note 2) Note that, if **U-03** is set to **1** (torque), data will be updated at intervals of more than 40 ms.

■ Adjustment scale with parameter **U-04** (Meter adjustment)

Connect meters as shown below.

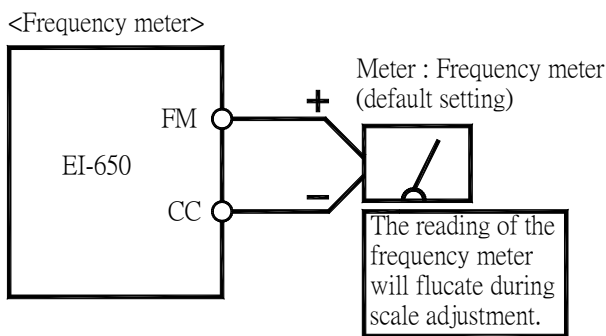



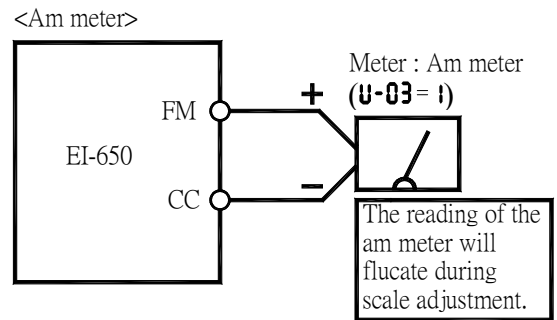











\* Optional frequency meter.

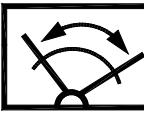

\* Make the maximum ammeter scale at least 150 percent of the inverter's rated output current.

[Example of how to adjustment the FM terminal frequency meter]

\* Use the meter's adjustment screw to pre-adjust zero-point.

Key operated	LED display	Operation
	600	Displays the operation frequency. (When standard monitor display selection <b>H- 10</b> is set to <b>0</b> [Operation frequency])
	U-H	The first basic parameter “ <b>U-H</b> ” (history function) is displayed.
 	U-04	Press either the  or the  key to select “ <b>U-04</b> ”.
	600	Press the  key to display the operation frequency.
 	600	Press either the  or the  key to adjust the meter. The meter reading will change at this time but be careful because there will be no change in the inverter's digital LED (monitor) indication.  [Hint] It's easier to make the adjustment if you push and hold for several seconds.
	600 ⇄ U-04	The adjustment is complete. <b>U-04</b> and the frequency are displayed alternately.
 + 	600	The display returns to its original indications. (When standard monitor display selection <b>H- 10</b> is set to <b>0</b> (Operation frequency))

### ■ Adjusting the meter in inverter stop state

\* Adjustment of output current (**U-03 = 1**)

If, when adjusting the meter for output current, there are large fluctuations in data during adjustment, making adjustment difficult, the meter can be adjusted in inverter stop state.

When setting **U-03** to **15** for fixed output 1 (100% output current), a signal of absolute values will be output (inverter's rated current = 100%). In this state, adjust the meter with the **U-04** (Meter adjustment) parameter.

Similarly, if you set **U-03** to **16** for fixed output 2 (output current at 50%), a signal that is sent out when half the inverter's rated current is flowing will be output through the FM terminal.

After meter adjustment is ended, set **U-03** to **1** (output current).

\* Adjustment of other items (U-03 = 0,2 to 14 )

If parameter U-03 is set to 17 : Fixed output 3 (Other than the output current: 100%), a signal that is sent out when U-03 is set to 0,2 to 14 (100%) will be output through the FM terminal. 100% standard value for each item is the following:

U-03 = 0,2, 12 : Maximum frequency (U-09 )

U-03 = 3,4 : 1.5 times of rated voltage

U-03 = 5,6 : 1.85 times of rated power

U-03 = 7,8 : 2.5 times of rated torque

U-03 = 9,10, 11 : Rated load factor

U-03 = 13, 14 : Maximum input value

## 6.6 Standard default setting and adjustment

### U-05 : Default setting

#### ■ Function

Allows setting of all parameters to the standard default setting, etc. at one time.

Note that U-14, U-03, A-09, d-70 - d-73, F-69 and L-80 will not be reset to their factory default settings.

Title	Function	Adjustment range	Default setting
U-05	Default setting	0: - 1: 50Hz default setting 2: 60Hz default setting 3: Standard default setting (Initialization) 4: Trip record clear 5: Cumulative operation time clear 6: Initialization of type information 7: Save user-defined parameters 8: Call user-defined parameters 9: Cumulative fan operation time record clear	0

★ This function will be displayed as 0 during reading on the right. This previous setting is displayed.

Example:

★ U-05 cannot be set during the inverter operating. Always stop the inverter first and then program.

## Programmed value

Default setting (**U-05 = 3**)

Setting **U-05** to **3** will return all parameters to the standard values that were programmed at the factory.

(Refer to 4.2.6)

- ☆ When 3 is programmed, < **In It** will be displayed for a short time after setting and will then be erased and displayed the original indication 0.0. Trip history data will be cleared at this time.

Trip clear (**U-05 = 4**)

Setting **U-05** to **4** initializes the past four sets of recorded error history data.

- ☆ The parameter does not change.

Cumulative operation time clear (**U-05 = 5**)

Setting **U-05** to **5** resets the cumulative operation time to the initial value (zero).

Cumulative operation time clear (**U-05 = 6**)

Setting **U-05** to **6** clears the trips when an **OPE2** format error occurs. But if the **OPE2** displayed, call us.

Save user setting parameters (**U-05 = 7**)

Setting **U-05** to **7** saves the current settings of all parameters. (Refer to 4.2.7)( Page 4-11).

Load user setting parameters (**U-05 = 8**)

Setting **U-05** to **8** loads parameter setting to (calls up) those saved by setting **U-05** to **7**. (Refer to 4.2.7)(Page 4-11)

By setting **U-05** to **7** or **8**, you can use parameters as your own default parameters.

Cumulative fan operation time record clear (**U-05 = 9**)

Setting **U-05** to **9** resets the cumulative operation time to the initial value (zero). Set this parameter when replacing the cooling fan, and so on.

## 6.7 Forward / reverse run selection (Operation panel operation)

### **U-06 : Forward / reverse run selection (operation panel operation)**





#### ■ Function

Program the direction of rotation of the motor when the running and stopping are mad using the RUN key and STOP key on the operation panel.

Valid when **U-01** (command mode) is set to **1** (operation panel).

## ■ Parameter setting

Title	Function	Adjustment range	Default setting
<b>U-06</b>	Forward / reverse run selection (Operation panel operation)	0: Forward run 1: Reverse run 2: Forward run (F/R switching possible) 3: Reverse run (F/R switching possible)	0

- ★ When **U-06** is set to **2** or **3** and an operating status is displayed, pressing the  key with the  key held down changes the direction of rotation from reverse to forward after displaying the message “**F<sub>r</sub>-F**”. Pressing the  key again with the  key held down changes the direction of rotation from forward to reverse after displaying the message “**F<sub>r</sub>-r**”.
- ★ Check the direction of rotation on the status monitor. For monitoring, see 8.1 (Page 8-1).  
**F<sub>r</sub>-F** : Forward run  
**F<sub>r</sub>-r** : Reverse run
- ★ When the F and R terminals are used for switching between forward and reverse rotation from the terminal board, the **U-06** forward / reverse run selection parameter is rendered invalid.  
Short across the F-CC terminals: forward rotation  
Short across the R-CC terminals: reverse rotation.
- ★ The inverter was factory-configured by default so that shorting terminals F-CC and terminals R-CC simultaneously would cause the motor to slow down to a stop. Using parameter **A-05**, however, you can choose between stop and reverse run.  
Using the parameter **A-05**, however, you can select between forward run and reverse run.
- ★ This function is valid only when **U-01** is set to **1** (operation panel).

## 6.8 Maximum frequency

### **U-09 : Maximum frequency**

#### ■ Function

- 1) Programs the range of frequencies output by the inverter (maximum output values).
- 2) This frequency is used as the reference for acceleration / deceleration time.

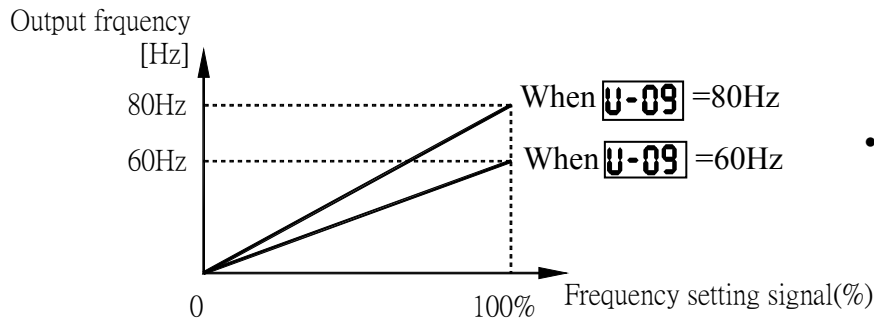

- This function determines the value in line with the ratings of the motor and load.
- Maximum frequency cannot be adjusted during operation. To adjust, first stop the inverter.

★ If **U-09** is increased, adjust the upper limit frequency **U-10** as necessary.

■ Parameter setting

Title	Function	Adjustment range	Default setting
<b>U-09</b>	Maximum frequency	30.0-500.0 (Hz)	80.0

## 6.9 Upper limit and lower limit frequencies

**U-10** : Upper limit frequency

**U-11** : Lower limit frequency

■ Function

Programs the lower limit frequency that determines the lower limit of the output frequency and the upper limit frequency that determines the upper limit of that frequency.

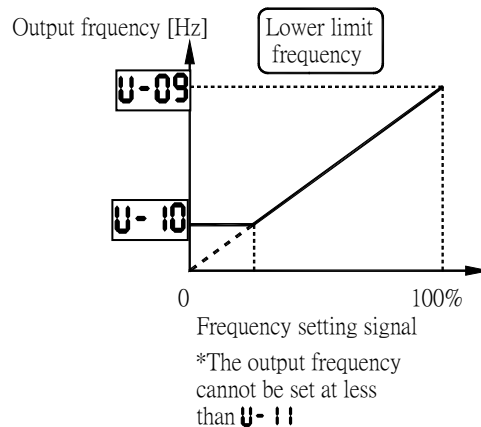
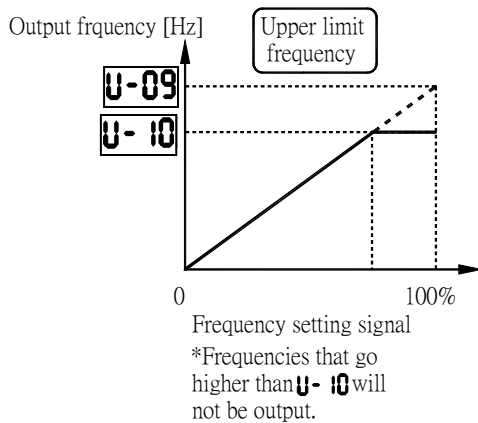

■ Parameter setting

Title	Function	Adjustment range	Default setting
<b>U-10</b>	Upper limit frequency	0.5 - <b>U-09</b> (Hz)	50.0
<b>U-11</b>	Lower limit frequency	0.0 - <b>U-10</b> (Hz)	0.0

## 6.10 Base frequency

**U- 12: Base frequency 1**

**U- 13: Base frequency voltage 1**

### ■ Function

Sets the base frequency and the base frequency voltage in conformance with load specifications or the Base frequency.

Note: This is an important parameter that determines the constant torque control area.

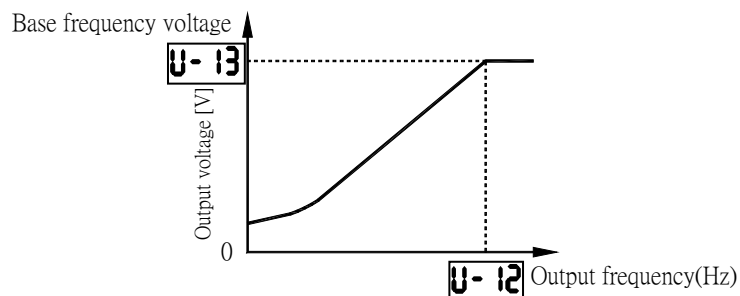

Title	Function	Adjustment range	Default setting
<b>U- 12</b>	Base frequency 1	25.0-500.0 (Hz)	50.0
<b>U- 13</b>	Base frequency voltage1	50-330 (V) : 240V class 50-660 (V) : 480V class	230 (240V class) 460 (480V class)

## 6.11 Selecting control mode

**U- 14 : V/F control mode selection**

### ■ Function

With EI-650, the V/F controls shown below can be selected.

- V/F constant
- Variable torque
- Automatic torque boost control \*1
- Vector control \*1
- Energy saving \*1
- Dynamic energy-saving (for fans and pumps)
- PM motor control

(\*1) Parameter setting macro torque boost: **CU-2** parameter can automatically set this parameter and auto-tuning at a time.









## ■ Parameter setting

Title	Function	Adjustment range	Default setting
<b>U- 14</b>	V/F control mode selection	0: V/F constant 1: Variable torque 2: Automatic torque boost control 3: Vector control 4: Energy-saving 5: Dynamic energy-saving (for fans and pumps) 6: PM motor control	2

Steps in setting are as follows

(In this example, the V/F control mode selection parameter **U- 14** is set to **3** (Vector control).

[Setting V/F control mode selection to **3** (sensorless vector control)]

Key operated	LED display	Operation
	<b>0. 0</b>	Displays the operation frequency.(Perform during operation stopped.) (When standard monitor display selection <b>H- 10</b> is set to <b>0</b> [Operation frequency])
	<b>CU-H</b>	The first basic parameter “ <b>CU-H</b> ” (history function) is displayed.
	<b>U- 14</b>	Press the  to change the parameter to <b>U- 14</b> (V/F control mode selection).
	<b>2</b>	Press the  key to display the parameter setting. (Standard default setting: <b>2</b> (automatic torque boost control).
	<b>3</b>	Press the  to change the parameter to <b>3</b> (vector control ).
	<b>3 ⇄ U- 14</b>	Press the  key to save the changed parameter. <b>U- 14</b> and parameter set value “ <b>3</b> ” are display alternately.

Warning:

When setting the V/F control mode selection parameter (**U- 14**) to any number between **2** and **6**, be sure to set at least the following parameters.

**d- 15**(Motor rated current): See the motor's nameplate.

**d- 16**(No-load current of motor): Refer to the motor test report.

**d- 17**(Rated rotational speed of motor): See the motor's nameplate.

Set also other torque boost parameters (**d-01** to **d-94**), as required.

### 1) Constant torque characteristics

Setting of V/F control mode selection **U- 14** to **0** (V/F constant)

This is applied to loads with equipment like conveyors and cranes that require the same torque at low speeds as at rated speeds.

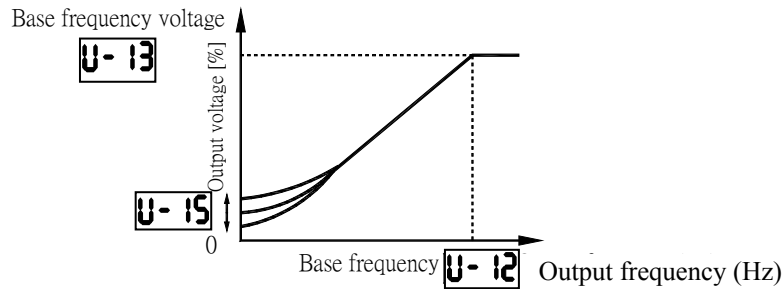

\* To increase the torque further, increase the setting value of the manual torque boost **U- 12**.  
⇒ For more details, see 6.12 (Page 6-25).

### 2) Setting for fans and pumps

Setting of V/F control mode selection **U- 14** to **1** (variable torque)

This is appropriate for load characteristics of such things as fans, pumps and blowers in which the torque in relation to load rotation speed is proportional to its square.

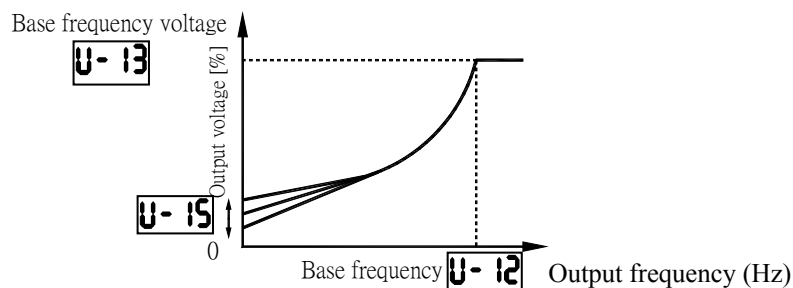

### 3) Increasing starting torque

Setting of V/F control mode selection **U- 14** to **2** (automatic torque boost control)

Detects load current in all speed ranges and automatically adjusts voltage output (torque boost) from inverter. This gives steady torque for stable runs.

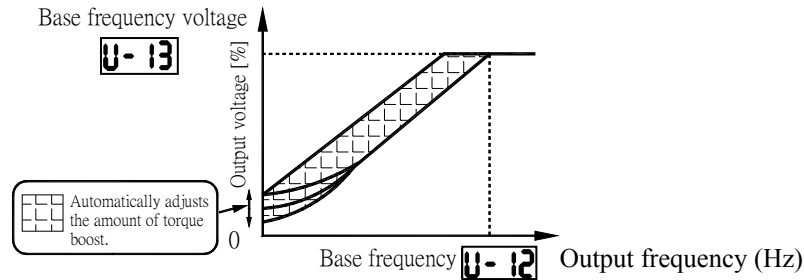

Note: This control system can oscillate and destabilize runs depending on the load. If that should happen, set V/F control mode selection **U- 14** to **0** (V/F constant) and increase torque manually.

★ Motor constant must be set

If the motor you are using is a standard motor and if it has the same capacity as the inverter, there is basically no need to set the motor constant. In any other case, be sure to set the parameters **d- 15** to **d- 17** properly.

Be sure to set **d- 15** (rated current of motor) and **d- 17** (rated speed of motor) correctly, as specified on the motor's nameplate. For the setting of **d- 16** (no-load current of motor), refer to the motor test report. There are three procedures for setting the other motor constants.

- 1) Auto torque boost and a motor constant (auto-tuning) can be set at once. To do so, set the basic parameter **CU-2** to **1** . ⇒ For details, see 1 in 6.2 (Page 6-3).
- 2) The motor constant can be automatically set (auto-tuning). Set the extended parameter **d-00** to **2** . ⇒ For details, see selection 2 in 7.17 (Page 7-52).
- 3) Each motor constant can be set individually. ⇒ For details, see selection 3 in 7.17 (Page 7-52).

4) Vector control - increasing starting torque and achieving high-precision operation.

Setting of V/F control mode selection **U- 14** to **3** (vector control)

Using sensor-less vector control with a standard motor will provide the highest torque at the low speed ranges.

- (1) Provides large starting torque.
- (2) Effective when stable operation is required to move smoothly up from the low speeds.
- (3) Effective in elimination of load fluctuations caused by motor slippage.

★ Motor constant must be set

If the motor you are using is a standard motor and if it has the same capacity as the inverter, there is basically no need to set the motor constant. In any other case, be sure to set the parameters **d- 15** to **d- 17** properly.

Be sure to set **d- 15** (rated current of motor) and **d- 17**(rated speed of motor) correctly, as specified on the motor's nameplate. For the setting of **d- 16** (no-load current of motor), refer to the motor test report. There are three procedures for setting the other motor constants.

- 1) The sensorless vector control and motor constants (auto-tuning) can be set at a time.  
Set the basic parameter **CU-2** to **2** . ⇒ For details, See 1 in 6.2 (Page 6-3).
- 2) The motor constant can be automatically set (auto-tuning).Set the extended parameter **d-00** to **2**. ⇒ For details, see selection 2 in 7.17 (Page 7-52).
- 3) Each motor constant can be set individually.  
⇒ For details, see selection 3 in 7.17 (Page 7-52).

## 5) Energy-saving

Setting of V/F control mode selection <b>U- 14</b> to <b>4</b> (Energy-saving)
--

Energy can be saved in all speed areas by detecting load current and flowing the optimum current that fits the load.

### ★ Motor constant must be set

If the motor you are using is a standard motor and if it has the same capacity as the inverter, there is no need to set the motor constant. In any other case, be sure to set the parameters **d- 15** to **d- 17** properly.

Be sure to set **d- 15**(rated current of motor) and **d- 17**(rated speed of motor) correctly, as specified on the motor's nameplate. For the setting of **d- 16** (no-load current of motor), refer to the motor test report. There are three procedures for setting the other motor constants.

- 1) Automatic energy-saving operation and a motor constant can be set at once. Set the basic parameter **CU-2** to **3** . ⇒ For details, see 1 in 6.2 (Page 6-3).
- 2) The motor constant can be automatically set (auto-tuning). Set the extended parameter **d-00** to **2**. ⇒ For details, see selection 2 in 7.17 (Page 7-52).
- 3) Each motor constant can be set individually.  
⇒ For details, see selection 3 in 7.17 (Page 7-52).

## 6) Achieving further energy savings

Setting of V/F control mode selection <b>U- 14</b> to <b>5</b> (Dynamic energy-saving)
--

More substantial energy savings than those provided by setting **U- 14** to **4** can be achieved in any speed range by keeping track of the load current and passing a current appropriate to the load. The inverter cannot respond to rapid load fluctuations, so that this feature should be used only for loads, such as fans and pumps, that are free of violent load fluctuations.

★ Motor constant must be set

If the motor you are using is a standard motor and if it has the same capacity as the inverter, there is no need to set the motor constant. In any other case, be sure to set the parameters **d- 15** to **d- 17** properly.

Be sure to set **d- 15** (rated current of motor) and **d- 17** (rated speed of motor) correctly, as specified on the motor's nameplate. For the setting of **d- 16** (no-load current of motor), refer to the motor test report.

For other types of motors, there are two ways to set a motor constant.

- 1) The motor constant can be set automatically (auto-tuning). Set the extended parameter **d-00** to **2** ⇒ For details, see selection 2 in 7.17 (Page 7-52).
- 2) Each motor constant can be set individually ⇒ For details, see selection 3 in 7.17 (Page 7-52).

7) Operating a permanent magnet motor

Setting of V/F control mode selection <b>U- 14</b> to <b>6</b> (PM motor control)
---

Permanent magnet motors (PM motors) that are light, small in size and highly efficient, as compared to induction motors, can be operated in sensor-less operation mode.

Note that this feature can be used only for specific motors. For more information, contact your Rich dealer.

8) Precautions on vector control

- 1) When exercising vector control, be sure to set the extended parameters **d- 15** to **d- 17** properly. Be sure to set **d- 15** (rated current of motor) and **d- 17** (rated speed of motor) correctly, as specified on the motor's nameplate. For the setting of **d- 16** (no-load current of motor), refer to the motor test report.
- 2) The sensorless vector control exerts its characteristics effectively in frequency areas below the base frequency (**U- 12**). The same characteristics will not be obtained in areas above the base frequency.
- 3) Set the base frequency to anywhere from 40 to 120Hz during vector control (**U- 14 = 3**).
- 4) Use a general purpose squirrel-cage motor with a capacity that is the same as the inverter's rated capacity or one rank below.  
The minimum applicable motor capacity is 0.1kW.
- 5) Use a motor that has 2-8 P.
- 6) Always operate the motor in single operation (one inverter to one motor).  
Sensorless vector control cannot be used when one inverter is operated with more than one motor.

- 7) The maximum length of wires between the inverter and motor is 30 meters. If the wires are longer than 30 meters, set standard auto-tuning with the wires connected to improve low-speed torque during sensorless vector control.  
However the effects of voltage drop cause motor-generated torque in the vicinity of rated frequency to be somewhat lower.
- 8) Connecting a reactor or surge voltage suppression filter between the inverter and the motor may reduce motor-generated torque. Setting auto-tuning may also cause a trip (RtE1) rendering sensorless vector control unusable.
- 9) The following table shows the relationship between the V/F control mode selection (U-14) and the motor constant parameter.  
Under normal conditions, be sure to set or adjust the parameters marked with ⊙.  
When making detailed settings, adjust the parameters marked with ○ as well, if necessary. Do not adjust the parameters marked with ×, because they are invalid.  
(For instructions about how to adjust the parameter d-00 and later, see section 7.17 Page 7-52.)

■ Relationship between V/F control mode selection (U-14) and Motor constant Parameter

⊙& ○ : Valid, × : Invalid

Title	Function	Parameter U-14 (V/F control mode selection)					
		0 V/F constant	1 Variable torque	2 Automatic torque boost control	3 Vector control	4 Energy- saving	5 Dynamic energy- saving
CU-2	Torque boost setting macro function	×	×	○	○	○	×
U-12	Base frequency 1	⊙	⊙	⊙	⊙	⊙	⊙
U-13	Base frequency voltage 1	⊙	⊙	⊙	⊙	⊙	⊙
U-15	Torque boost value 1	⊙	⊙	×	×	×	×
R-70	Base frequency 2	○	×	×	×	×	×
R-71	Base frequency voltage 2	○	×	×	×	×	×
R-72	Torque boost value 2	○	×	×	×	×	×
d-00	Auto-tuning	×	×	○	○	○	○
d-01	Slip frequency gain	×	×	×	○	×	×
d-02	Automatic torque boost Value	×	×	⊙	⊙	⊙	⊙
d-15	Motor rated current	○	○	⊙	⊙	⊙	⊙
d-16	Motor no-load current	×	×	○	○	○	○
d-17	Motor rated speed	○	○	⊙	⊙	⊙	⊙
d-18	Speed control response Coefficient	×	×	○	○	○	○
d-19	Speed control stability coefficient	×	×	○	○	○	○
d-80	Exciting current Coefficient	×	×	○	○	×	×
d-85	Stall prevention control coefficient 1	○	○	○	○	○	○
d-92	Stall prevention control coefficient 2	○	○	○	○	○	○
d-94	Motor adjustment coefficient	○	○	○	○	○	○

⊙: Be sure to set and adjust the parameters

○: Adjust the parameters if necessary.

## 6.12 Manual torque boost - increasing torque boost at low speeds

### U- 15 : Torque boost 1

#### ■ Function

If torque is inadequate at low speeds, increase torque by raising the torque boost rate with this parameter.

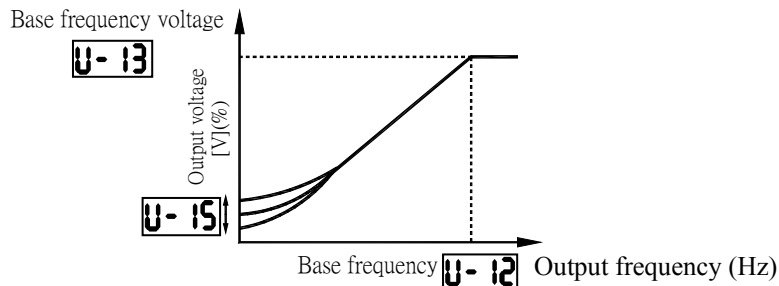

#### [Parameters]

Title	Function	Adjustment range	Default setting
U- 15	Torque boost 1	0.0 - 30.0 (%)	According to model (See Chapter 5, Page 5-21 )

★ Valid when U- 14 is set to 0 (V/F constant) or 1 (square reduction)

Note 1: The optimum value is programmed for each inverter capacity. Be careful not to increase the torque boost rate too much because it could cause an overcurrent trip at startup.

## 6.13 Setting the electronic thermal

### U- 16 : Motor electronic-thermal protection level 1

### U- 17 : Electronic thermal protection characteristic selection

### R- 73 : Motor electronic-thermal protection level 2

### F- 07 : Motor 150%-overload time limit

#### ■ Function

This parameter allows selection of the appropriate electronic thermal protection characteristics according to the particular rating and characteristics of the motor.

## ■ Parameter setting

Title	Function	Adjustment range				Default setting
<b>U-16</b>	Motor electronic thermal protection level 1	10 – 100 (%) / (A)				100
<b>U-17</b>	Electronic-thermal protection characteristic selection	Setting value		Overload protection	Overload stall	0
		0	Standard motor	○	×	
		1		○	○	
		2		×	×	
		3		×	○	
		4	VF motor (special motor)	○	×	
		5		○	○	
		6		×	×	
7	×	○				
<b>A-73</b>	Motor electronic-thermal protection level 2	10 – 100 (%) / (A)				100
<b>F-07</b>	Motor 150%-overload time limit	10 – 2400 (s)				300

- 1) Setting the electronic thermal protection characteristics selection **U-17** and motor electronic thermal protection level 1 **U-05** , 2 **A-73**

The electronic thermal protection characteristics selection **U-17** is used to enable or disable the motor overload trip function (**OL-2**) and the overload stall function. While the inverter overload trip (**OL-1**) will be in constant detect operation, the motor overload trip (**OL-2**) can be selected using the parameter **U-17**.

### Explanation of terms

**Overload stall:** This is an optimum function for equipment such as fans, pumps and blowers with variable torque characteristics that the load current decreases as the operating speed decreases.

When the inverter detects an overload, this function automatically lowers the output frequency before the motor overload trip **OL-2** is activated. This function operates a motor at frequencies that allow the load current to keep its balance so that the inverter can continue operation without being tripped.

Note: Do not use the overload stall function with loads having constant torque characteristics (such as conveyor belts in which load current is fixed with no relation to speed).

[Using standard motors (other than motors intended for use with inverters)]

When a motor is used in the lower frequency range than the rated frequency, that will decrease the cooling effects for the motor. This speeds up the start of overload detection operations when a standard motor is used in order to prevent overheating.

■ Setting of electronic thermal protection characteristics selection **U- 17**

Setting value	Overload protection	Overload stall
0	○	×
1	○	○
2	×	×
3	×	○

○ : valid, ×: invalid





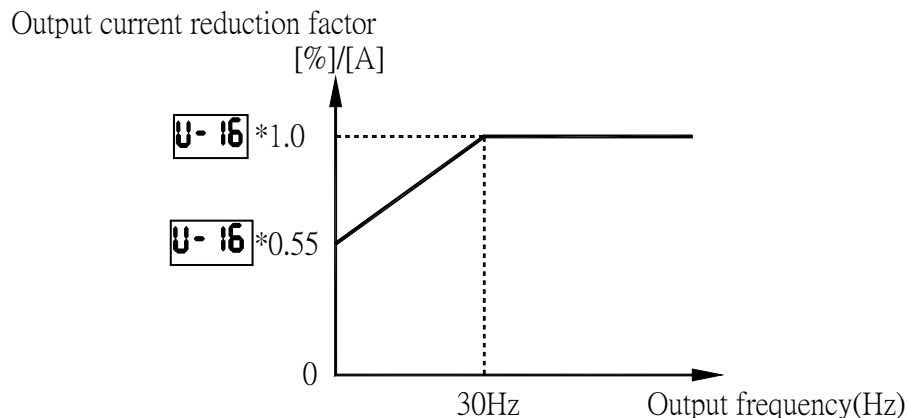





■ Setting of motor electronic thermal protection level 1 **U- 16** (Same as **R- 73**)

If the capacity of the motor is smaller than the capacity of the inverter, or the rated current of the motor is smaller than the rated current of the inverter, adjust the electronic thermal protection level 1 **U- 16** so that it fits the motor's rated current.



Note: The motor overload protection start level is fixed at 30Hz.

[Example of setting: When the EI-650-01L (1HP Inverter) is running with motor having 2A rated current]

Key operated	LED display	Operation
	00	Displays the operation frequency. (Perform during operation stopped.) (When standard monitor display selection <b>H- 10</b> is set to <b>0</b> [Operation frequency])
	CU-H	The first basic parameter “ <b>CU-H</b> ” (history function) is displayed.
 	U- 16	Press either the  key or the  key to change the parameter to <b>U- 16</b> .
	100	Press the  key to display the parameter setting. (Standard default setting: 100%)
 	42	Press the  key to change the parameter to 42% (=motor rated current/inverter output rated current x100=2.0//4.8×100).
	42 ⇄ U- 16	Press the ENTER key to save the changed the parameter. <b>U- 16</b> and the parameter are displayed alternately.

Note: The rated output current of the inverter should be calculated from the rated current for frequencies below 4kHz, regardless of the setting of the PWM carrier frequency parameter (**C-00**).

[Using a VF motor (motor for use with inverter)]

■ Setting of electronic thermal protection characteristics selection **U- 17**

Setting value	Overload protection	Overload stall
4	○	×
5	○	○
6	×	×
7	×	○

○ : valid, × : invalid

VF motors (motors designed for use with inverters) can be used in frequency ranges lower than those for standard motors, but their cooling efficiency decreases at frequencies below 6Hz.

■ Setting of motor electronic thermal protection level 1 **U-16** (Same as **A-73**)

If the capacity of the motor is smaller than the capacity of the inverter, or the rated current of the motor is smaller than the rated current of the inverter, adjust the electronic thermal protection level 1 **U-16** so that it fits the motor's rated current.

\* If the indications are in percentages (%), then 100% equals the inverter's rated output current (A).

Output current reduction factor [%]/[A]

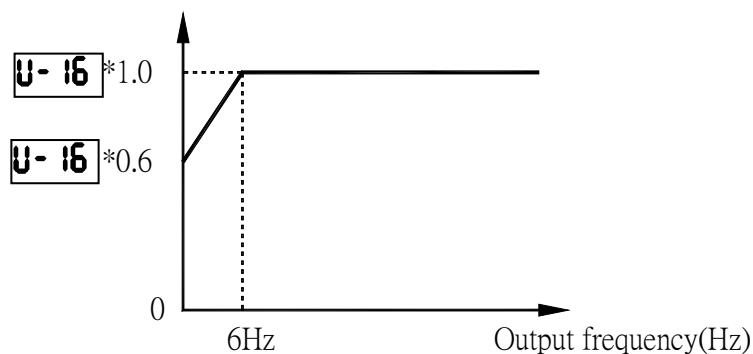

Setting the motor overload starting level

2) Motor 150%-overload time limit **F-07**

Parameter **F-07** is used to set the time elapsed before the motor trips under a load of 150% (overload trip **OL-2**) within a range of 10 to 2400 seconds.

3) Inverter over load characteristics

Set to protect the inverter unit. Cannot be changed or turned off by parameter setting.

To prevent the inverter overload trip function (**OL-1**) from being activated too easily, lower the stall prevention level (**F-01**) or increase the acceleration time (**U-07**) or deceleration time (**U-08**).

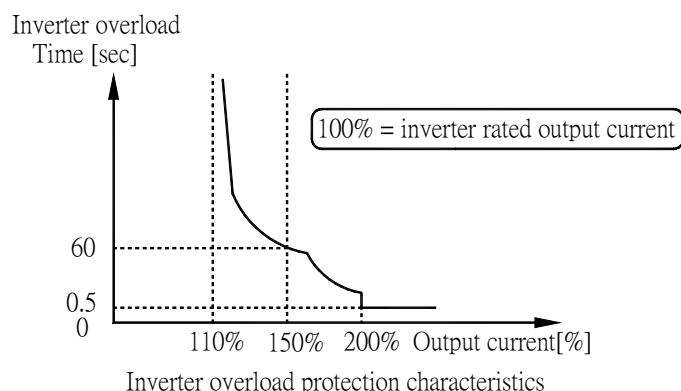

\* To protect the inverter, overload trip or overcurrent trip activate in a short period of time when output current reaches 150% or higher.

## 6.14 Preset-speed operation (speeds in 15 steps)

**U-01: Command mode selection**  
**U-18-U-24: Preset-speed operation frequencies 1-7**  
**b-87-b-94: Preset-speed operation frequencies 8-15**

### ■ Function

A maximum of 15 speed steps can be selected just by switching an external contact signal. Multi-speed frequencies can be programmed anywhere from the lower limit frequency **U-11** to the upper limit frequency **U-10**.

When fire-speed control is assigned to the terminal board, the function of setting fire-speed operation frequencies is assigned to **b-94**. See 7.11.2 (Page 7-32), Fire-speed control.

[Setting method]

### 1) Run/stop

The starting and stopping control is done from the terminal board.

Title	Function	Adjustment range	Default setting
<b>U-01</b>	Command mode selection	0: Terminal board 1: Operation panel	0

Note: If speed commands (analog signal or digital input) are switched in line with preset-speed operations, select the terminal board using the frequency setting mode selection **U-02**.

⇒ See 3) (Page 3-1) or 6.4 (Page 6-9)

### 2) Preset-speed frequency setting

Set the speed (frequency) of the number of steps necessary.

Setting from speed 1 to speed 7

Title	Function	Adjustment range	Default setting
<b>U-18-U-24</b>	Preset-speed operation frequencies 1-7	<b>U-11 - U-10</b> (Hz)	0.0

Setting from speed 8 to speed 15

Title	Function	Adjustment range	Default setting
<b>b-87-b-94</b>	Preset-speed operation frequencies 8-15	<b>U-11 - U-10</b> (Hz)	0.0

Examples of preset-speed contact input signals: Slide switch SW1 set to sink logic

O: ON -: OFF (Speed commands other than preset-speed commands are valid when all are OFF)

Terminal	Preset-speed															
	1	2	3	4	5	6	7	8	9	10	11	12	13	14	15	
S1-CC	○	-	○	-	-	-	○	-	○	-	○	-	○	-	○	
S2-CC	-	○	○	-	-	○	○	-	-	○	○	-	-	○	○	
S3-CC	-	-	-	○	○	○	○	-	-	-	-	○	○	○	○	
RES-CC	-	-	-	-	-	-	-	○	○	○	○	○	○	○	○	

☆ Terminal functions are as follows.

Terminal S1..... Input terminal function selection 4 (S1)

**R-14 = 6** (Preset-speed command 1: SS1)

Terminal S2..... Input terminal function selection 5 (S2)

**R-15 = 7** (Preset-speed command 2: SS2)

Terminal S3..... Input terminal function selection 6 (S3)

**R-16 = 8** (Preset-speed command 3: SS3)

Terminal RES..... Input terminal function selection 3 (RES)

**R-13 = 9** (Preset-speed command 4: SS4)

☆ SS4 is not allocated to standard default setting. Use the input terminal function selection to allocate SS4 an idle terminal. In the above example the RES terminal is used for SS4.

[Example of a connection diagram]  
(SW1 set to sink logic NPN position)

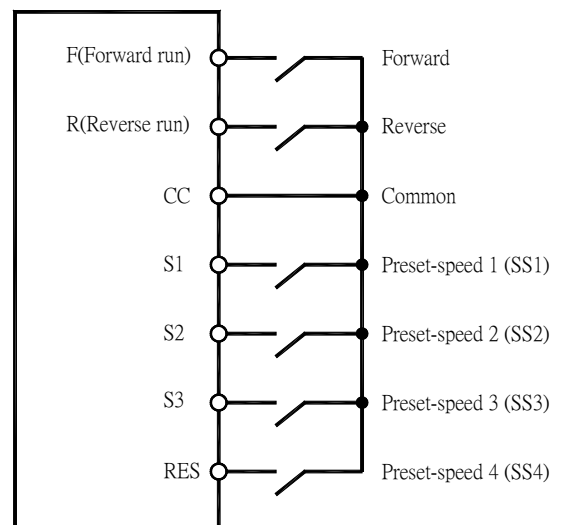

### 3) Using other speed commands with preset-speed command

Command mode selection <b>U-01</b>		0: Terminal board				1: Operation panel			
Frequency setting mode selection <b>U-02</b>		0: Built-in potentiometer	1: VIA 2: VIB 5: UP / DOWN or 6: VIA+VIB	3: Operation panel	4: Communication	0: Built-in potentiometer	1: VIA 2: VIB 5: UP / DOWN or 6: VIA+VIB	3: Operation panel	4: Communication
Preset-speed command	Entered	Preset-speed command valid Note)				Potentiometer command valid	Terminal command valid	Operation panel command valid	Communication command valid
	Not entered	Potentiometer command valid	Terminal command valid	Operation panel command valid	Communication command valid	(The inverter doesn't accept Preset-speed command.)			

Note) The preset-speed command is always given priority when other speed commands are input at the same time.

Below is an example of 7-step speed operation with standard default setting.

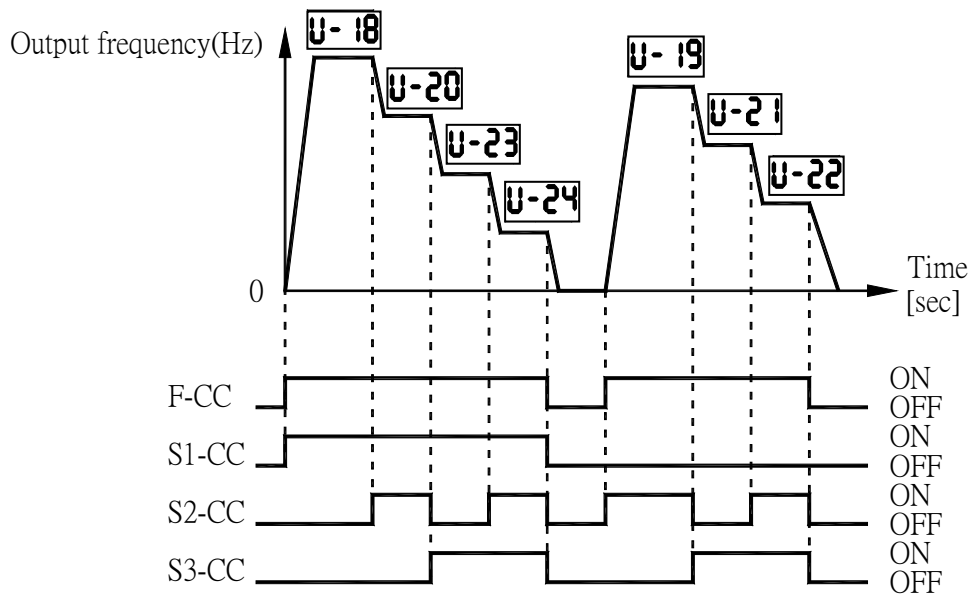

Example of 7-step speed operation

## 7. Extended parameters

Extended parameters are provided for sophisticated operation, fine adjustment and other special purposes. Modify parameter settings as required. See Ch 5, Page 5-6 Table of extended parameters.

### 7.1 Input/output parameters

#### 7.1.1 Low-speed signal

**A-00 : Low-speed signal output frequency**  
**A-30 : Output terminal selection 1A (RY-RC)**

#### ■ Function

When the output frequency exceeds the setting of **A-00** an ON signal will be generated. This signal can be used as an electromagnetic brake excitation / release signal. This signal can also be used as an operation signal when **A-00** is set to 0.0Hz, because an ON signal is put out if the output frequency exceeds 0.0Hz.

- ★ Relay output (250Vac-1A (cosφ=1), 30Vdc-0.5A, 250Vac-0.5A(cosφ=0.4) at RY-RC, FLA-FLC-FLB terminals (Default setting : RY-RC).
- ★ If the inverter is so set, the signal will be put out through the open collector OUT and NO output terminals (24 Vdc-Max. 50mA).

[Parameter setting]

Title	Function	Adjustment range	Default setting
<b>A-00</b>	Low-speed signal output frequency	0.0 - <b>U-09</b> (Hz)	0.0

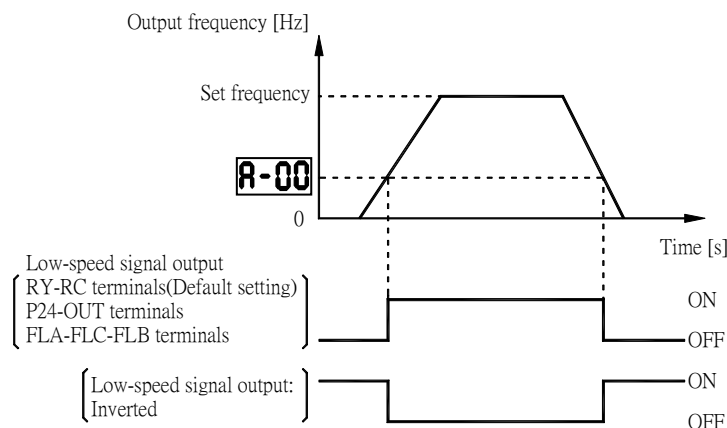

An example of the connection of the open collector OUT terminal

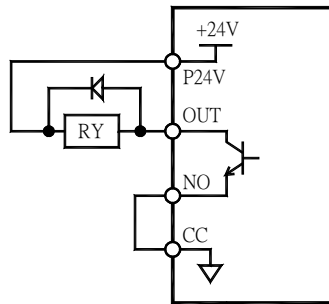

An example of the connection of the relay output terminals

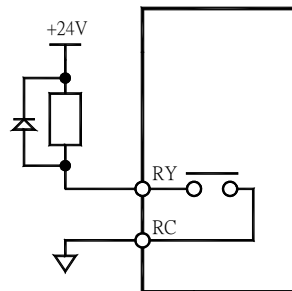

#### ■ Output terminal setting

Output of the low-speed signal (ON signal) between the RY and RC terminals is the factory default setting of the output terminal selection parameter. This setting must be changed to invert the polarity of the signal.

[ Parameter setting]

Title	Function	Adjustment range	Default setting
<b>A-30</b>	Output terminal selection 1A (RY-RC)	0 - 255 (See Ch 5, Page 5-25)	4 (ON Signal) or 5 (OFF signal)

Set **A-30** to output to OUT-NO terminals.

### 7.1.2 Output of designated frequency reach signal

**A-02** : Speed reach detection band  
**A-31** : Output terminal selection 2A (OUT-NO)

#### ■ Function

When the output frequency becomes equal to the setting by designated frequency  $\pm$  **A-02**, an ON or OFF signal is generated.

#### ■ Parameter setting of designated frequency and detection band

Title	Function	Adjustment range	Default setting
<b>A-02</b>	Speed reach detection band	0.0 - <b>U-09</b> (Hz)	2.5

■ Parameter setting of output terminal selection

Title	Function	Adjustment range	Default setting
<b>A-31</b>	Output terminal selection 2A (OUT-NO)	0-255 (See Ch 5, Page 5-25)	6: RCH (designated frequency – ON signal) or 7: RCHN (designated frequency-OFF signal)

Note: Select the **A-30** parameter to specify RY-RC terminal output, or the **A-32** parameter to specify FLA-FLC-FLB terminal output.

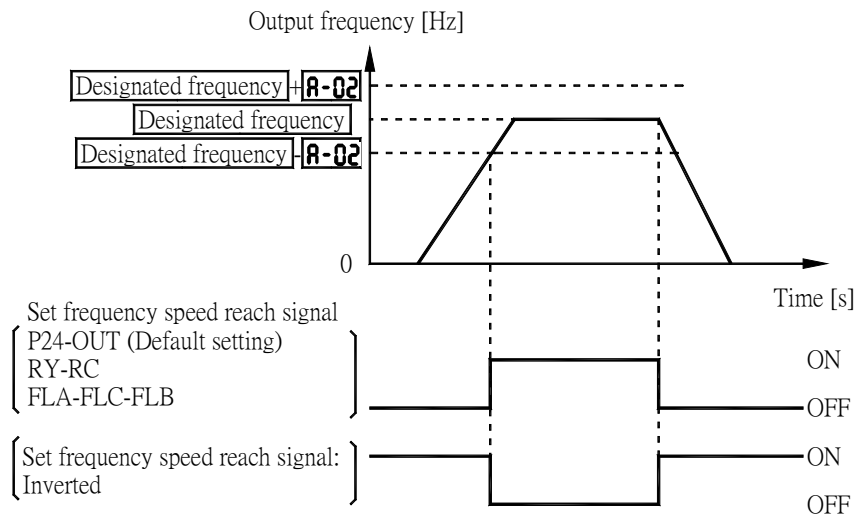

7.1.3 Output of set frequency speed reach signal

- A-01** : Speed reach setting frequency
- A-02** : Speed reach detection band
- A-31** : Output terminal selection 2A (OUT-NO)

■ Function

When the output frequency becomes equal to the frequency set by **A-01** ± **A-02**, an ON or OFF signal is generated

■ Parameter setting of frequency and detection band

Title	Function	Adjustment range	Default setting
<b>A-01</b>	Speed reach setting frequency	0.0 - <b>U-09</b> (Hz)	0.0
<b>A-02</b>	Speed reach detection band	0.0 - <b>U-09</b> (Hz)	2.5

■ Parameter setting of output terminal selection

Title	Function	Adjustment range	Default setting
<b>A-31</b>	Output terminal selection 2A (OUT-NO)	0 - 255 (See Ch 5, Page 5-25)	8: RCHF (designated frequency-ON signal), or 9: RCHFN (designated frequency-OFF signal)

Note: Select the **A-30** parameter to specify RY-RC terminal output, or set the **A-32** parameter function No. to 8 or 9 to specify FLA-FLC-FLB terminal output.

If the detection band value + the set frequency is less than the designated frequency

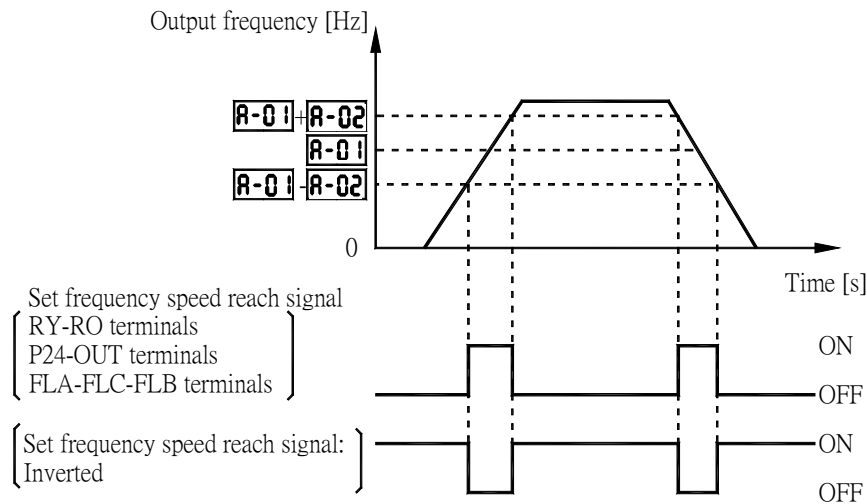

## 7.2 Input signal selection

### 7.2.1 Priority selection (both F-CC, R-CC are ON)

**A-05 : Priority selection (both F-CC, R-CC are ON)**

■ Function

This parameter allows you to select the direction in which the motor runs when a forward run (F) command and a reverse run (R) command are entered simultaneously.

- 1) Reverse
- 2) Slowdown stop

■ Parameter setting

Title	Function	Adjustment range	Default setting
<b>A-05</b>	Priority selection (both F-CC, R-CC are ON)	0: Reverse 1: Slowdown Stop	1

[ **R-05 = 1** (Stop)]: If an F command and an R command are entered Simultaneously **the motor will slow down to a stop.**

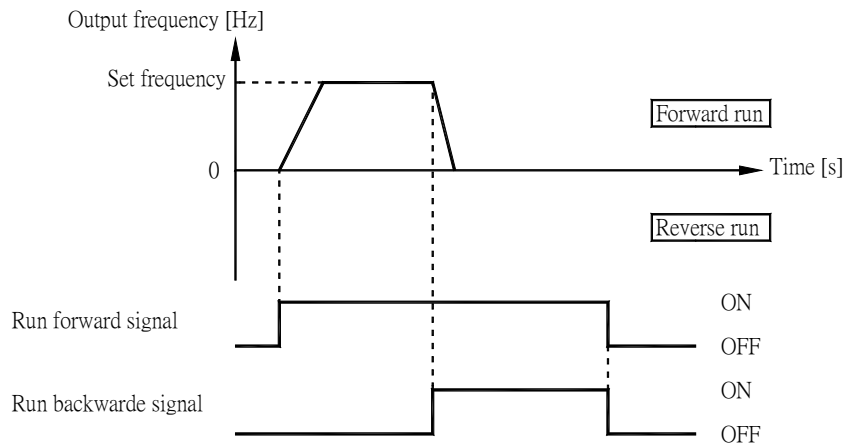

[ **R-05 = 0** (Reverse)]: If an F command and an R command are entered simultaneously **the motor will run in the reverse direction.**

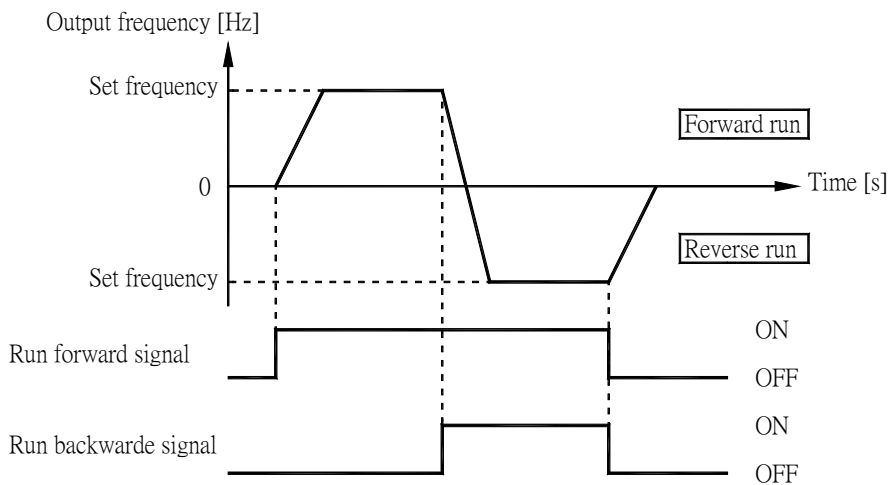

## 7.2.2 Changing the functions of VIA and VIB terminals

### **R-09 : VIA/VIB terminals function selection**

#### ■ Function

This parameter allows you to choose between signal input and contact signal input for the VIA and VIB terminals.

■ Parameter setting

Title	Function	Adjustment range	Default setting
<b>R-09</b>	Analog/contact input function selection (VIA/VIB terminal)	0: VIA-analog input VIB-analog input 1: VIA-analog input VIB-contact input (Sink) 2: VIA-analog input VIB-contact input (Source) 3: VIA-contact input (Sink) VIB-contact input (Sink) 4: VIA-contact input (Source) VIB-contact input (Source)	0

- When using the VIA and VIB terminals as contact input terminals in sink logic connection, be sure to insert a resistor between the P24 terminal and the VIA/VIB terminals. (Recommended resistance: 4.7kΩ-1/2W)

Note: When using the VIA terminal as a contact input terminal, be sure to turn the VIA slide switch to the V position.

- ★ The Figure on the right shows an example of the connection of input terminals VIA and VIB when they are used as contact input terminals. This example illustrates the connection when the inverter is used in sink logic mode.
- ★ The figure on the right shows an example of the connection of input terminals VIA and VIB when they are used as contact input terminals. This example illustrates the connection when the inverter is used in sink (Negative) logic mode.

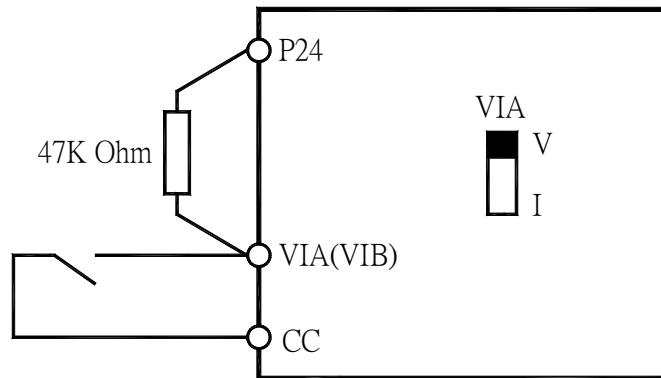

## 7.3 Terminal function selection

### 7.3.1 Keeping an input terminal function always active (ON)

#### **A-10 : Always-active function selection 2**

##### ■ Function

This parameter specifies an input terminal function that is always to be kept active (ON).

##### ■ Parameter setting

Title	Function	Adjustment range	Default setting
<b>A-10</b>	Always-active function selection 2	0 – 65 (See Page 5-22)	1 (Standby)

##### ★ Coast stop

The standard default setting is for deceleration stop. To make a coast stop, assign a “1(ST)” terminal function to an idle terminal using the programmable terminal function. Change to **A-10=0**. For coast stop, open the ST-CC when stopping the motor in the state described at left. The monitor on the inverter at this time will display **OFF**.

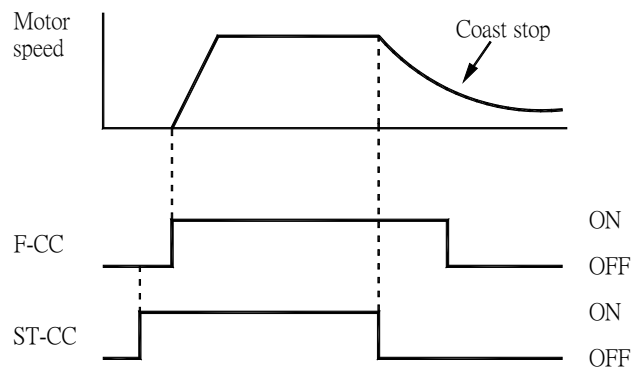

### 7.3.2 Modifying input terminal functions

- A-11 : Input terminal selection 1 (F)**
- A-12 : Input terminal selection 2 (R)**
- A-13 : Input terminal selection 3 (RES)**
- A-14 : Input terminal selection 4 (S1)**
- A-15 : Input terminal selection 5 (S2)**
- A-16 : Input terminal selection 6 (S3)**
- A-17 : Input terminal selection 7 (VIB)**
- A-18 : Input terminal selection 8 (VIA)**

■ Function

Use the above parameters to send signals from an external programmable controller to various control input terminals to operate and / or set the inverter.

The desired contact input terminal functions can be selected from 66 types (0 to 65). This gives system design flexibility. (Note, however, for **R- 17** and **R- 18** , a function can be selected from among 13 functions (5 to 17).)

- Note that the setting 52 (forced operation) can be enabled only when the inverter is so configured at the factory. For more information, contact your local Rich dealer.
- The functions of the VIB and VIA terminals can be selected between analog input and contact input by changing parameter settings **R-09** . To use the VIA and VIB terminals as contact input terminals, you need to set **R-09** to the number(1 to 4) that suits your needs, since analog input (voltage signal input) is assigned to the terminals by default.

■ Setting of contact input terminal function

Terminal symbol	Title	Function	Adjustment range	Default setting
-	<b>R- 10</b>	Always-active function selection 2	0 - 65 (See Page 5-22~5-25)	1(ST)
F	<b>R- 11</b>	Input terminal selection1 (F)		2(F)
R	<b>R- 12</b>	Input terminal selection2 (R)		3(R)
RES	<b>R- 13</b>	Input terminal selection3 (RES)		10(RES)
S1	<b>R- 14</b>	Input terminal selection4 (S1)		6(SS1)
S2	<b>R- 15</b>	Input terminal selection5 (S2)		7 (SS2)
S3	<b>R- 16</b>	Input terminal selection6 (S3)		8 (SS3)
VIB	<b>R- 17</b>	Input terminal selection7 (VIB)	5-17 (Note 2) (See Page 5-22~5-25)	9(SS4)
VIA	<b>R- 18</b>	Input terminal selection8 (VIA)		5(AD2)

Note 1. The function that has been selected using **R- 10** (always-active function selection parameter) are always activated.

Note 2. When using the VIA and VIB terminals as contact input terminals in sink logic connection, be sure to insert a resistor between the P24 terminal and the VIA / VIB terminals. (Recommended resistance: 4.7kΩ – 1/2W)  
be sure to turn the VIA slide switch to the V position.

Note 3. **R- 17** (VIB): Enabled only when **R-09** = **1** to **4**  
Disabled and the set value cannot be read out, if **R-09** is set at **0** .

Note 4. **R- 18** (VIA): Enabled only when **R-09** = **3** or **4**  
Disabled and the set value cannot be read out, if **R-09** is set at **0** to **2** .

■ Connection method

1) A-contact input

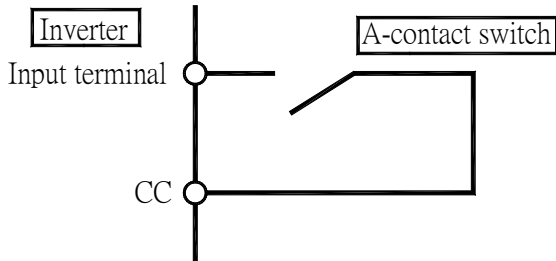

Sink setting

- This function is activated when the input terminal and CC (common) are short circuited. Use this function to specify forward/reverse run or a preset-speed operation.

2) Connection with transistor output

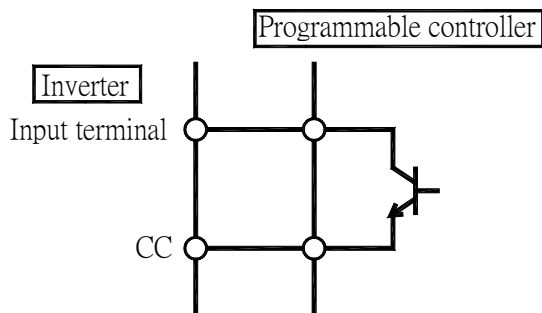

- Operation can be controlled by connecting the input and CC (common) terminals to the output (no-contacts switch) of the programmable controller. Use this function to specify forward/reverse run or a preset-speed operation. Use a transistor that operates at 24Vdc/5mA.

※ Interface between programmable controller and inverter

Note 1 : When using a programmable controller with open collector outputs for control, connect it to the PLC terminal, as shown in the figure below, to prevent the inverter from malfunctioning because of a current that flows in.

**Also, be sure to turn the SW1 slide switch to the PLC position.**

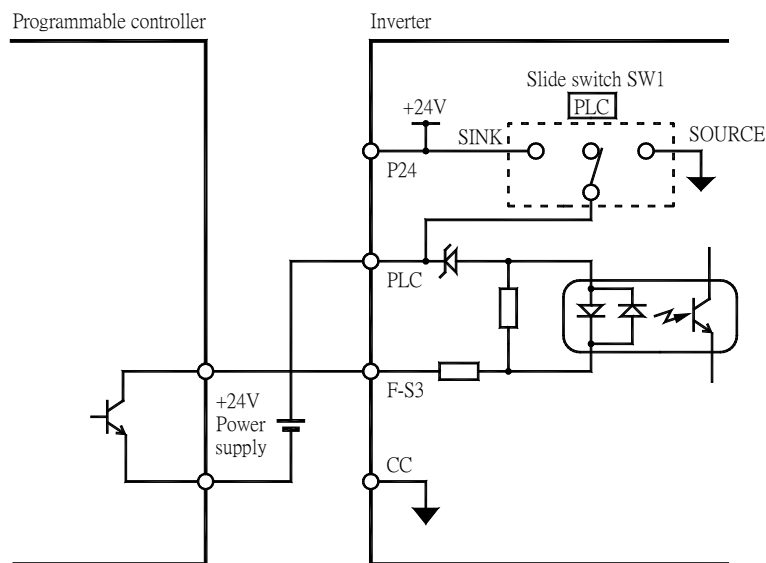

### 3) Sink logic / source logic input

Sink logic / source (input / output terminal logic) switching is possible.

For more details, see 2.2.2 (Page 2-4).

## 7.3.3 Modifying output terminal functions

**A-30** : Output terminal selection 1A (RY-RC)  
**A-31** : Output terminal selection 2A (OUT-NO)  
**A-32** : Output terminal selection 3 (FLA, FLB, FLC)

### ■ Function

Use the above parameters to send various signals from the inverter to external equipment. By setting parameters for the RY-RC, OUT-NO and FL (FLA, FLB and FLC) terminals on the terminal board, you can use 58 functions and functions obtained by combining them.

To assign only one function to output terminals, assign the function to **A-30** and **A-31** while leaving **A-31** to **A-39** as they are set by default.

### ■ Example of application

Function of FLA, B, C:

Can be set using parameter **A-32**

Function of RY-RC:

Can be set using parameter **A-30, A-31, A-39**

Function of OUT-NO:

Can be set using parameter **A-31, A-38, A-39**

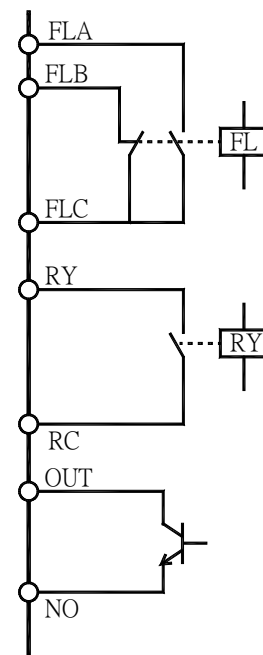

■ Assigning one function to an output terminal

Terminal symbol	Title	Function	Adjustment range	Default setting
RY-RC-	<b>A-30</b>	Output terminal selection 1A	0 - 255 (See Chapter 5 Page 5-25~5-28)	4 (Low-speed detection signal)
OUT-NO	<b>A-31</b>	Output terminal selection 2A		6 (Designated frequency reach)
FL (A,B,C)	<b>A-32</b>	Output terminal selection 3		10(Failure FL)

- ★ When assigning one function to each output terminal, set parameters **A-30** to **A-32** only do not change but leave parameters **A-31** to **A-39** as they were set by default. (Standard default setting: **A-31**=255, **A-38**=255, **A-39**=0)

7.3.4 Assigning two functions to an output terminal

**A-30** : Output terminal selection 1A (RY-RC)  
**A-31** : Output terminal selection 2A (OUT-NO)  
**A-37** : Output terminal selection 1B (RY-RC)  
**A-38** : Output terminal selection 2B (OUT-NO)  
**A-39** : Output terminal logic selection (RY-RC, OUT-NO)

■ Function

2 different functions can be assigned to the terminal board output terminals RY-RC and OUT-NO. Signals of 2 functions of the logical product (AND) or logical sum (OR) selected form 58 functions can be output to 1 output terminal.

Note: **A-38** (OUT-NO): Enabled only when **F-69** = 0

Disabled and the set value cannot be read out, if **F-69** is set at 1 .

(1) A signal is sent out when the two functions assigned are activated simultaneously.

Terminal symbol	Title	Function	Adjustment range	Default setting
RY-RC-	<b>A-30</b>	Output terminal selection 1A	0 - 255 (See Chapter 5 Page 5-25~5-28)	4 (Low-speed detection signal)
OUT-NO	<b>A-31</b>	Output terminal selection 2A		6 (Designated frequency reach)
RY-RC	<b>A-37</b>	Output terminal selection 1B		255 (Always ON)
OUT-NO	<b>A-38</b>	Output terminal selection 2B		

- ★ Two different functions can be assigned to terminals RY-RC and terminals OUT-NO.  
★ If parameter **A-39** is set to 0 (default), a signal will be sent out when the two functions assigned are activated simultaneously. Terminals RY-RC: Send out a signal when the functions assigned with **A-30** and **A-37** are activated simultaneously. Terminals

OUT-NO: Send out a signal when the functions assigned with **A-31** and **A-38** are activated simultaneously.

Timing chart

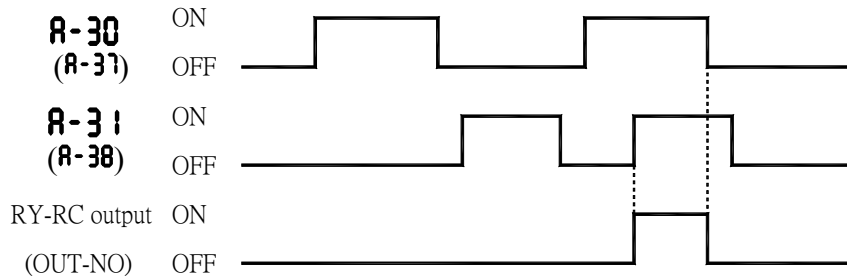

★ Only one function can be assigned to terminals FLA-FLB-FLC at a time.

(2) A signal is sent out when either of the two functions assigned is activated.

Terminal symbol	Title	Function	Adjustment range	Default setting
RY-RC	<b>A-30</b>	Output terminal selection 1A	0 - 255 (See Chapter 5 Page 5-25~5-28)	4 (Low-speed detection signal)
OUT-NO	<b>A-31</b>	Output terminal selection 2A		6 (Designated frequency reach)
RY-RC	<b>A-37</b>	Output terminal selection 1B		255 (Always ON)
OUT-NO	<b>A-38</b>	Output terminal Selection 2B		255 (Always ON)
RY-RC / OUT-NO	<b>A-39</b>	Output terminal logic selection	0: <b>A-30</b> and <b>A-37</b> <b>A-31</b> and <b>A-38</b> 1: <b>A-30</b> or <b>A-37</b> <b>A-31</b> and <b>A-38</b> 2: <b>A-30</b> and <b>A-37</b> <b>A-31</b> or <b>A-38</b> 3: <b>A-30</b> or <b>A-37</b> <b>A-31</b> or <b>A-38</b>	0

★ Two different functions can be assigned to terminals RY-RC and terminals OUT-NO.

★ If parameter **A-39** is set to **3**, a signal will be sent out when either of the two functions assigned is activated.

Terminals RY-RC: Send out a signal when either of the functions set with **A-30** and **A-37** is activated.

Terminals OUT-NO: Send out a signal when either of the functions set with **A-31** and **A-38** is activated.

Timing chart

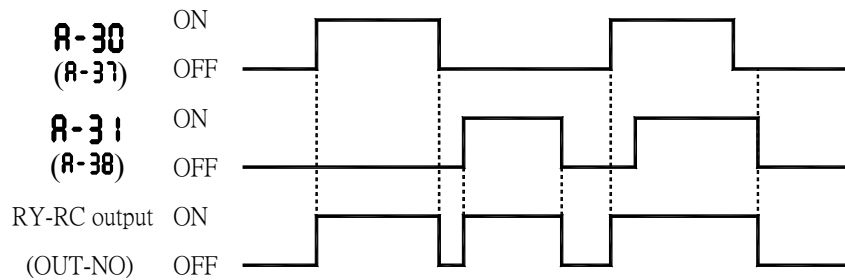

★ Only one function can be assigned to terminals FLA-FLB-FLC at a time.

(3) The logical product (AND) or logical sum (OR) of the two functions assigned is put out as a signal.

■ Setting of output terminal function.

Terminal symbol	Title	Function	Adjustment range	Default setting
Y-RC	<b>A-30</b>	Output terminal selection 1A	0-255 (See Chapter 5 Page 5-25~5-28)	4 (Low-speed detection signal)
OUT-NO	<b>A-31</b>	Output terminal selection 2A		6 (Designated frequency reach)
FL (A,B,C)	<b>A-32</b>	Output terminal selection 3		10 (Failure FL)
RY-RC	<b>A-37</b>	Output terminal selection 1B		255 (Always active)
OUT-NO	<b>A-38</b>	Output terminal selection 2B		255 (Always active)
RY-RC / OUT-NO	<b>A-39</b>	Output terminal logic selection	0: <b>A-30</b> and <b>A-37</b> <b>A-31</b> and <b>A-38</b> ----- 1: <b>A-30</b> or <b>A-37</b> <b>A-31</b> and <b>A-38</b> ----- 2: <b>A-30</b> and <b>A-37</b> <b>A-31</b> or <b>A-38</b> ----- 3: <b>A-30</b> or <b>A-37</b> <b>A-31</b> or <b>A-38</b>	0

Two different functions can be assigned to the output terminals (RY-RC and OUT-NO), and two logics with different functions can be selected using **A-39** .

The logical product (AND) or logical sum (OR) of the two functions assigned is put out as a signal, depending on the setting of parameter **A-39**.

If **A-39 = 0**, the logical sum (AND) of **A-30** and **A-31** will be output to RY-RC.

The logical product (OR) of **A-31** and **A-38** will be output to OUT-NO.

If **A-39 = 1**, the logical product (OR) of **A-30** and **A-31** will be output to RY-RC.

The logical sum (AND) of **A-31** and **A-38** will be output to OUT-NO.

If **A-39 = 2**, the logical sum (AND) of **A-30** and **A-31** will be output to RY-RC.

The logical product (OR) of **A-31** and **A-38** will be output to OUT-NO.

If **A-39 = 3**, the logical product (OR) of **A-30** and **A-31** will be output to RY-RC.

The logical product (OR) of **A-31** and **A-38** will be output to OUT-NO.

★ To assign only one function to output terminals, assign the function to **A-30** and **A-31** while leaving **A-31** to **A-39** as they are set by default.

Note: **A-38** (OUT-NO): Enable only when **F-69 = 0**

Disabled and the set value cannot be read out, if **F-69** is set to 1.

#### (4) Holding the output of signals in ON status

★ If the conditions for activating the functions assigned to output terminals RY-RC and OUT-NO agree with and as a result the output of signals is put in ON status, the output of signals is held ON, even if the conditions change. (Output terminal holding function)

★ Assign input terminal function 62 or 63 to a contact input terminal available.

#### ■ Input Terminal function

Function No.	Code	Function	Action
62	HRDRY	Holding of RY-RC terminal output	ON: Once turned on, RY-RC are held on. OFF: The status of RY-RC changes in real time according to conditions.
63	HDOUT	Holding of OUT-NO terminal output	ON: Once turned on, OUT-NO are held on. OFF: The status of OUT-NO changes in real time according to conditions.

★ Once output terminal RY-RC or OUT-NO is turned on when the contact input terminal to which one of the above functions (function 62 or 63) is assigned is ON, output terminal RY-RC or OUT-NO is held ON.

### 7.3.5 Comparing the frequency command values

**A-67** : Frequency command agreement detection range  
**U-02** : Frequency setting mode selection 1  
**b-07** : Frequency setting mode selection 2

■ Function

In the frequency command value specified using **U-02** (or **b-07**) almost agree with the frequency command value from the VA terminal with an accuracy of  $\pm$  the setting of **A-67**, and ON or OFF signal will be sent out..

■ Frequency command value and agreement detection range parameter setting

Title	Function	Adjustment range	Default setting
<b>A-67</b>	Frequency command agreement detection range	0.0 - <b>U-09</b> (Hz)	2.5
<b>U-02</b>	Frequency setting mode selection 1	0 - 6	0
<b>b-07</b>	Frequency setting mode selection 2	(See Ch5, Page 5-1~5-5)	1

Note: To put out signals RY-RC, OUT or FLA-FLB-FLC, set **A-30**, **A-31**, or **A-32** respectively to 52 or 53.

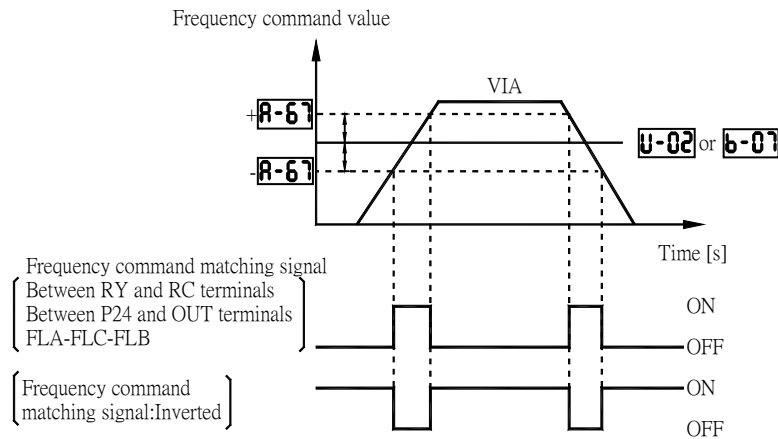

Note: This function can be used, for example, to send out a signal indicating whether the amount of processing and the amount of feedback agree with each other when the PID function is in use.

For an explanation of the PID function, See 7.16 (Page 7-48).

## 7.4 Basic parameter 2

### 7.4.1 Switch motor characteristics via terminal input

**A-70** : Base frequency 2  
**A-71** : Base frequency voltage 2  
**A-72** : Torque boost 2  
**A-73** : Motor electronic-thermal protection level 2  
**A-85** : Stall prevention level 2

#### ■ Function

Use the above parameters to switch the operation of two motors with a signal inverter and to select motor V/F characteristics (two types) according to the particular needs or operation mode.

Note: The **U-14** (V/F control mode selection) parameter is enabled only motor1.

If motor 2 is selected, V/F control will be given constant torque characteristics.

#### ■ Parameter setting

Title	Function	Adjustment range	Default setting
<b>A-70</b>	Base frequency 2	25.0 - 500.0 (Hz)	50.0
<b>A-71</b>	Base frequency voltage 2	50-330(V):240V class 50-660 (V):480V class	230 (240V class) 460 (480V class)
<b>A-72</b>	Torque boost 2	0.0 - 30.0 (%)	Depending on model (See Ch 5, Page 5-21)
<b>A-73</b>	Motor electronic-thermal protection level 2	10 - 100 (%) / (A)	100
<b>A-85</b>	Stall prevention level 2	10-199 (%) / (A), 200 :Disabled	150

#### ■ Setting of switch terminals

The terminal for switching to motor 2 needs to be set, since this function is not assigned under the default setting. Assign this function to an idle terminal.

The parameters to be switched depend on the particular identification number of the input terminal selection function.

Input terminal function number					Parameters used and applicable parameters
5 AD2	39 VF2	40 MOT2	58 AD3	61 OCS2	
OFF	OFF	OFF	OFF	OFF	Default setting:: U-14,U-12,U-13,U-15,U-16,U-07,U-08, E-02,F-01
ON	OFF	OFF	OFF	OFF	U-07→E-00,U-08→E-01,E-02→E-03
-	OFF	OFF	ON	OFF	U-07→E-10,U-08→E-01,E-02→E-12
OFF	OFF	OFF	OFF	OFF	F-01→A-85
OFF	ON	OFF	OFF	ON	U-14→0,U-12→A-70,U-13→ A-71,U-15→A-72,U-16→A-73
-	-	ON	OFF	-	U-14→0,U-12→A-70,U-13→A-71,U-15→ A-72,U-16→A-73,F-01→A-85,U-07→ E-00,U-08→E-01,E-02→E-03

Note. The parameters **U-12,U-13,U-14,A-70** and **A-71** cannot be switched during operation. You need to stop operation when switching them.

## 7.5 Frequency priority selection

### 7.5.1 Using a frequency command according to the particular situation

**U-02 : Frequency setting mode selection 1**  
**b-00 : Frequency priority selection**  
**b-07 : Speed setting mode selection 2**

#### ■ Function

These parameters are used to switch between two types of frequency command signals.

- Seeing by parameters
- Switching by frequency
- Switching via terminal board input

## ■ Parameter setting

Title	Function	Adjustment range	Default setting
<b>U-02</b>	Frequency setting mode selection 1	0: Built-in potentiometer 1: VIA 2: VIB 3: Operation panel 4: Serial communication 5: UP/DOWN from external contact 6: VIA+VIB (Override)	0
<b>b-00</b>	Frequency priority selection	0: <b>U-02</b> (Switchable to <b>b-01</b> by the input terminal ) 1: <b>U-02</b> ( <b>b-01</b> for output frequencies equal to or lower than 1.0 Hz)	0
<b>b-01</b>	Frequency setting mode selection 2	0: Built-in potentiometer 1: VIA 2: VIB 3: Operation panel 4: Serial communication 5: UP/DOWN from external contact 6: VIA+VIB (Override)	1

### 1) External switching (Input terminal function 38: FCHG enabled)

#### **Frequency priority selection parameter b-00 = 0**

Switching between the command specified with **U-02** and **b-01** can be made by entering a command from a terminal board.-

To do so, however, the frequency command forced switching function (input terminal function selection:38) needs to be set before hand to an input terminal board.

If an OFF command is entered to the input terminal board: The command specified with **U-02** will be selected.

If an ON command is entered to the input terminal board: The command specified with **b-01** will be selected.

### 2) Automatic switching by frequency command

#### **Frequency priority selection parameter b-00 = 1**

The switching between the command specified with **U-02** and **b-01** is done automatically according to the frequency command entered.

If the frequency set with **U-02** is above 1Hz: The command specified with **U-02** will be selected.

If the frequency set with **U-02** is 1Hz or less: The command specified with **b-01** will be selected.

## 7.5.2 Setting frequency command characteristics

**b-01** : VIA input point 1 setting  
**b-02** : VIA input point 1 frequency  
**b-03** : VIA input point 2 setting  
**b-04** : VIA input point 2 frequency  
**b-10** : VIB input point 1 setting  
**b-11** : VIB input point 1 frequency  
**b-12** : VIB input point 2 setting  
**b-13** : VIB input point 2 frequency  
**L-11** : Communication command point 1 setting  
**L-12** : Communication command point 1 frequency  
**L-13** : Communication command point 2 setting  
**L-14** : Communication command point 2 frequency

### ■ Function

These parameters adjust the output frequency according to the externally applied analog signal (0-10Vdc voltage, 4-20mA dc current) and the entered command for setting an external contact frequency.

o fine adjust the frequency command characteristics for VIA/VIB input, use parameters **d-70** to **d-73** .(See section 7.5.4. Page 7-23)

### ■ Parameter setting

Title	Function	Adjustment range	Default setting
<b>b-01</b>	VIA input point 1 setting	0-100 (%)	0
<b>b-02</b>	VIA input point 1 frequency	0.0-500.0 (Hz)	0.0
<b>b-03</b>	VIA input point 2 setting	0-100 (%)	100
<b>b-04</b>	VIA input point 2 frequency	0.0-500.0 (Hz)	50.0
<b>b-10</b>	VIB input point 1 setting	0-100 (%)	0
<b>b-11</b>	VIB input point 1 frequency	0.0-500.0 (Hz)	0.0
<b>b-12</b>	VIB input point 2 setting	0-100 (%)	100
<b>b-13</b>	VIB input point 2 frequency	0.0-500.0 (Hz)	50.0
<b>L-11</b>	Communication command point 1 setting	0-100 (%)	0
<b>L-12</b>	Communication command point 1 frequency	0.0-500.0 (Hz)	0.0
<b>L-13</b>	Communication command point 2 setting	0-100 (%)	100
<b>L-14</b>	Communication command point 2 frequency	0.0-500.0 (Hz)	60.0

Note 1: Don't set the same value between point 1 and point 2. If set the same value, the **Err 1** is displayed.

## 1) 0-10Vdc voltage input adjustment (VIA, VIB)

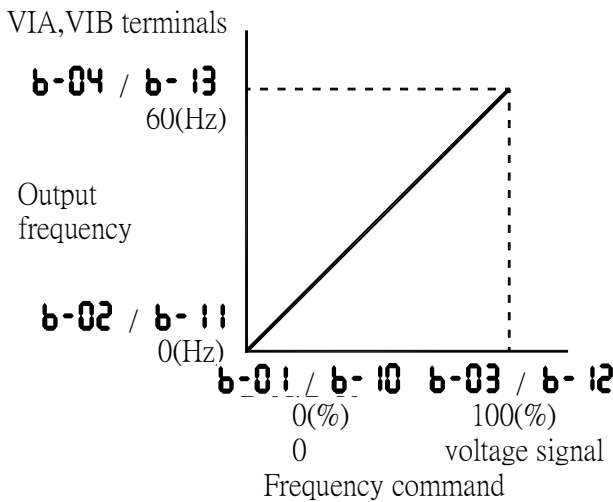

- The output frequency with respect to the voltage input is adjusted according to the selected reference point.
- Gradient and bias can be set easily.

## 2) 4-20mA current input adjustment (VIA: VIA slide switch in the I position)

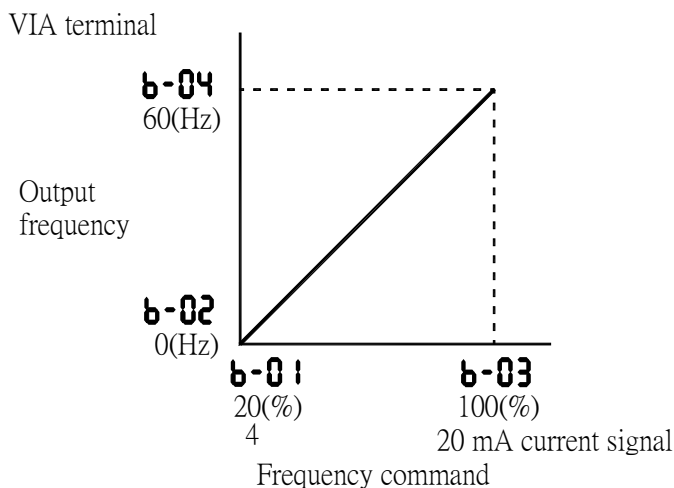

- The output frequency with respect to the current input is adjusted according to the selected reference point.
- Gradient and bias can be set easily.
- Set **b-01** to **0** to create a current input from 0 to 20mA.

### 7.5.3 Setting of frequency with the input from an external contact

**b-64** : External contact input-UP response time  
**b-65** : External contact input-UP frequency steps  
**b-66** : External contact input-DOWN response time  
**b-67** : External contact input-DOWN frequency steps  
**b-68** : Initial up/down frequency  
**b-69** : Change of the initial up/down frequency

#### ■ Function

These parameters are used to set an output frequency by means of a signal from an external device.

Title	Function	Adjustment range	Default setting
<b>b-64</b>	External contacts input - UP response time	0.0 - 10.0 (S)	0.1
<b>b-65</b>	External contacts input - UP frequency steps	0.0 - <b>U-09</b> (Hz)	0.1
<b>b-66</b>	External contacts input - DOWN response time	0.0 - 10.0 (S)	0.1
<b>b-67</b>	External contacts input - DOWN frequency step	0.0 - <b>U-09</b> (Hz)	0.1
<b>b-68</b>	Initial up/down frequency	<b>U-10</b> - <b>U-11</b> (Hz)	0.0
<b>b-69</b>	Change of the initial up/down frequency	0: Not changed 1: Setting of <b>b-68</b> changed when power is turned off	1

- These function take effect when parameter **U-02** (frequency setting mode selection 1) is set to **5** or parameter **b-07** (frequency setting mode selection 2) is set to **5** is enabled.

■ Adjustment with continuous signals (Parameter-setting example 1)

Set parameters as follows to adjust the output frequency up or down in proportion to the frequency adjustment signal input time:

Panel frequency incremental gradient = **b-65** / **b-64** setting time

Panel frequency decremental gradient = **b-67** / **b-66** setting time

Set parameters as follows to adjust the output frequency up or down almost in synchronization with the adjustment by the panel frequency command:

$$\mathbf{b-64} = \mathbf{b-66} = 1$$

$$(\mathbf{U-09} / \mathbf{U-07} \text{ (or } \mathbf{E-00})) \geq (\mathbf{b-65} / \mathbf{b-64} \text{ setting time)}$$

$$(\mathbf{U-09} / \mathbf{U-08} \text{ (or } \mathbf{E-01})) \geq (\mathbf{b-67} / \mathbf{b-66} \text{ setting time)}$$

<<Sample sequence diagram 1: Adjustment with continuous signals>>

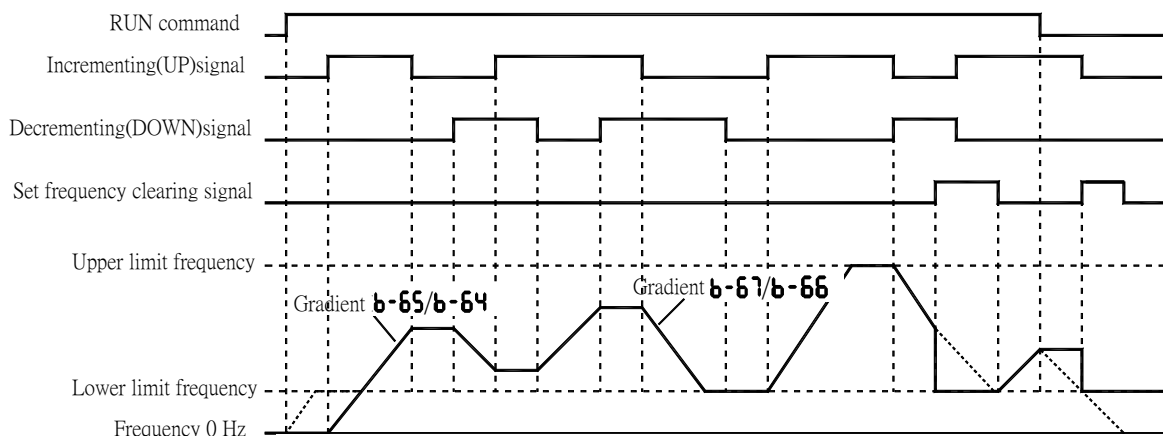

The dotted line denotes the output frequency obtained by combining the slowdown speed and the panel frequency adjustment speed.

Note: If the operation frequency is set to the lower limit frequency, it will increase from 0Hz when power is turned on for the first time after the setting, and therefore the output frequency will not rise until the operation frequency reaches the lower limit frequency. (Operation at the lower limit frequency)

In this case, the time required for the operation frequency to reach the lower limit frequency can be shortened by setting **b-66** to the lower limit frequency.

■ Adjustment with pulse signals (Parameter-setting example 2)

Set parameters as follows to adjust the frequency in steps of one pulse:

**b-64**, **b-66** ≤ Pulse On time

**b-65**, **b-67** = Frequency obtained with each pulse

- The inverter does not respond to any pulses with an ON time shorter than that set with **b-64** or **b-66**. 12ms or more of clearing signal is allowed.

<<Sample sequence diagram 2: Adjustment with pulse signals>>

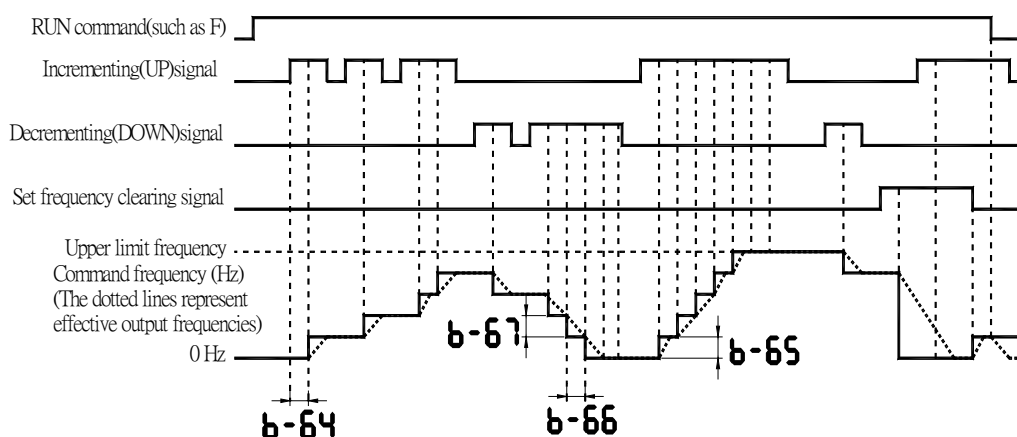

■ If two signals are impressed simultaneously

- If a clear single and an up down signal are impressed simultaneously, priority will be given to the clear signal.
- If up and down signals are impressed simultaneously, The frequency will change at the specified up or down rate.

■ About the setting of the initial up/down frequency

To adjust the frequency starting at a specified frequency other than 0.0Hz (default initial frequency) after turning on the inverter, specify the desired frequency using **b-68** (initial up/down frequency).

■ About the change of the initial up/down frequency

To make the inverter automatically save the frequency immediately before it is turned off and start operation at that frequency next time power is turned on, set **b-69** (change of initial up / down frequency) to 1 (which changes the setting of **b-68** when power is turned off). Keep in mind that the setting of **b-68** is changed each time power is turned

off.

■ Frequency adjustment range

The frequency can be set from 0.0Hz to **U-09** (Maximum frequency). The lower-limit frequency will be set as soon as the set frequency clearing function (function number 43,44) is entered from the input terminal.

■ Minimum unit of frequency adjustment

If **H-02** (Frequency free unit magnification) is set to 1.00, the output frequency can be adjusted in steps of 0.01Hz.

### 7.5.4 Fine adjustment of frequency setting signal

**d-70** : VIA input bias  
**d-71** : VIA input gain  
**d-72** : VIB input bias  
**d-73** : VIB input gain

■ Function

These parameters are used to fine adjust the relation between the frequency setting signal input through the analog input terminals VIA and VIB and the output frequency.

Use these parameters to make fine adjustments after making rough adjustments using the parameters **b-01** to **b-13**

The figure below shows the characteristic of the frequency setting signal input through the VIA and VIB terminals and that of the output frequency.

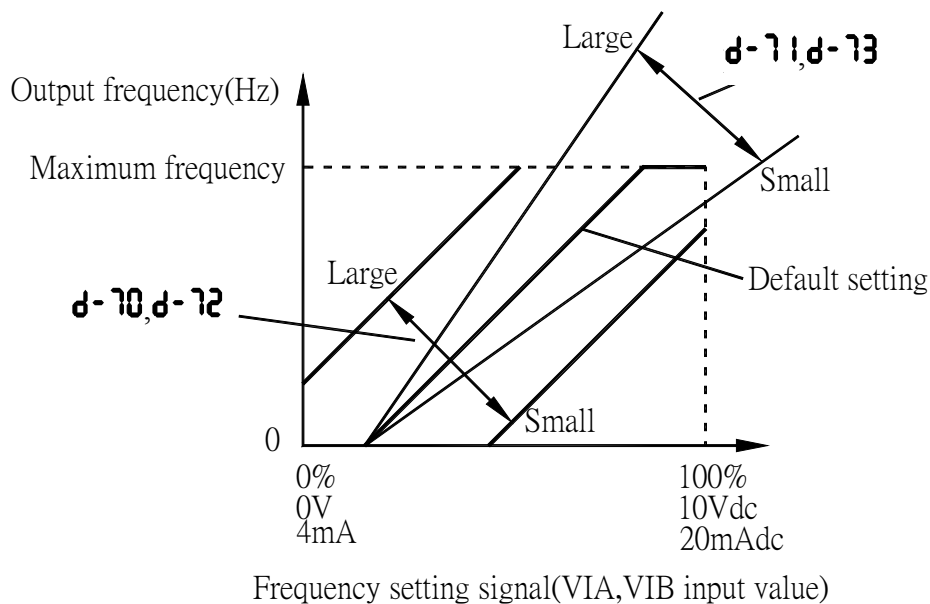

- ※ Bias adjustment of VIA and VIB input terminals (**d-70** and **d-72**)  
To give leeway, the inverter is factory-adjusted by default so that it will not produce an output until a certain amount of voltage is applied to the VIA and VIB input terminals. If you want to reduce the leeway, set **d-70** or **d-72** to a larger value. Note that specifying a too large value may cause an output frequency to be output, even though the operation frequency is 0 (zero) Hz.
- ※ Gain adjustment of VIA and VIB input terminals (**d-71** and **d-73**)  
The inverter is factory-adjusted by default so that the operation frequency can reach the maximum frequency, even though the voltage and current to the VIA and VIB input terminals are below the maximum levels. If you want to adjust the inverter so that it will output the maximum frequency at the maximum voltage and current, set **d-71** or **d-73** to a smaller value. Note that specifying a too small value may cause the operation frequency not to reach the maximum frequency, even though the maximum voltage and current are applied.

## 7.6 Operation frequency

### 7.6.1 Starting frequency

#### **b-40** : Starting frequency setting

##### ■ Function

The frequency set with **b-40** is put out as soon as operation is started.

Use the **b-40** parameter when a delay in response of starting torque according to the acceleration / deceleration time is probably affecting operation. Setting the starting frequency to a value from 0.5 to 3Hz is recommended. The occurrence of an overcurrent can be suppressed by setting this frequency below the rated slippage of the motor.

[Parameter setting]

Title	Function	Adjustment range	Default setting
<b>b-40</b>	Starting frequency setting	0.5 - 10.0 (Hz)	0.5

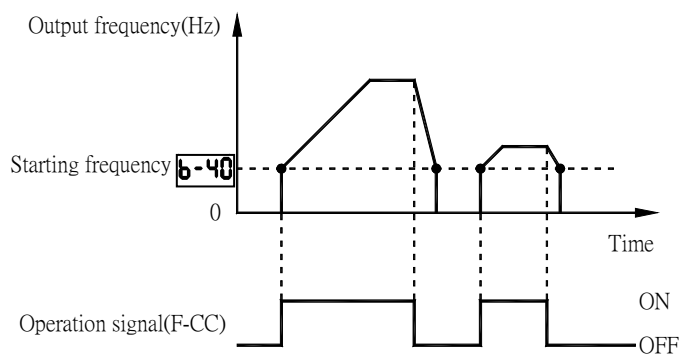

## 7.6.2 Run/Stop control with frequency setting signals

**b-41** : Operation starting frequency  
**b-42** : Operation starting frequency hysteresis

### ■ Function

The Run/Stop of operation can be controlled simply with frequency setting signals.

[Parameter setting]

Title	Function	Adjustment range	Default setting
<b>b-41</b>	Operation starting frequency	0.0 - <b>U-09</b> (Hz)	0.0
<b>b-42</b>	Operation starting frequency hysteresis	0.0 - <b>U-09</b> (Hz)	0.0

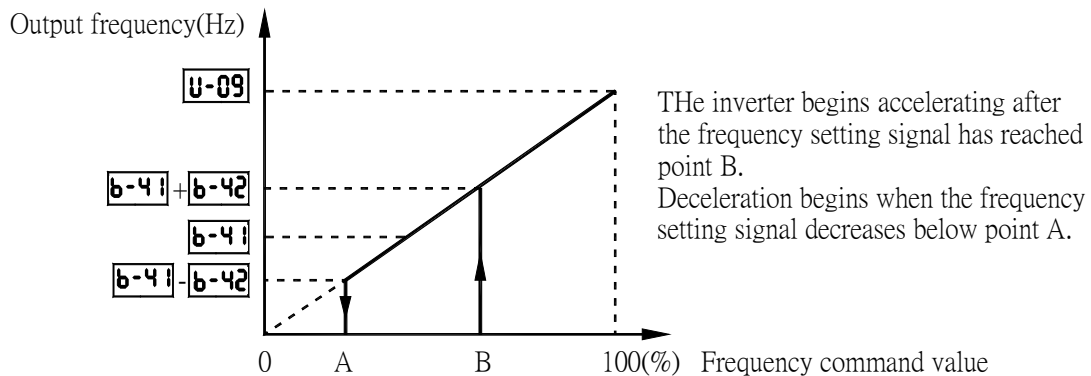

## 7.7 DC braking

### 7.7.1 DC braking

**b-50** : DC braking starting frequency  
**b-51** : DC braking current  
**b-52** : DC braking time

### ■ Function

A large braking torque can be obtained by applying a direct current to the motor. These parameters set the direct current to be applied to the motor, the application time and the starting frequency.

[Parameter setting]

Title	Function	Adjustment range	Default setting
<b>b-50</b>	DC braking starting frequency	0.0 - <b>U-09</b> (Hz)	0.0
<b>b-51</b>	DC braking current	0-100 (%) / (A)	50
<b>b-52</b>	DC braking time	0.0-20.0 (sec)	1.0

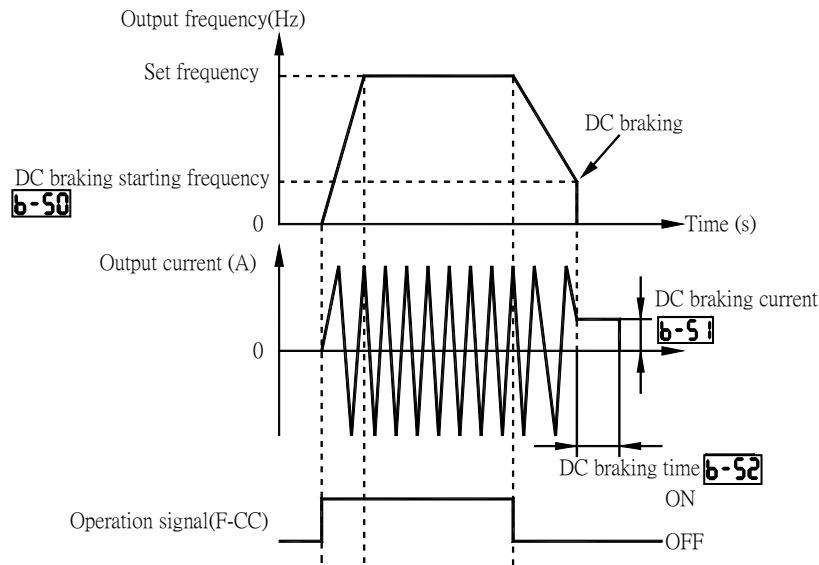

Note 1: During DC braking, the overload protection sensitivity of the inverter increases. The DC braking current may be adjusted automatically to prevent tripping.

Note 2: During DC braking, the carrier frequency is 4kHz or less irrespective of the setting of parameter **ƒ-00** (PWM carrier frequency).

## 7.7.2 Motor shaft fixing control

### **b-54 : Motor shaft fixing control**

#### ■ Function

This function is used to prevent the motor from running unexpectedly because its shaft is not restrained or to preheat the motor.

[Parameter setting]

Title	Function	Adjustment range	Default setting
<b>b-54</b>	Motor shaft fixing control	0: Disabled, 1: Enabled	0

If the motor shaft fixing control **b-54** is set to 1, half the braking force set with **b-51** (DC braking rate) will be applied to the motor to continue DC braking even after the completion of ordinary DC braking. To stop motor shaft fixing control, turn off the standby command (ST signal).

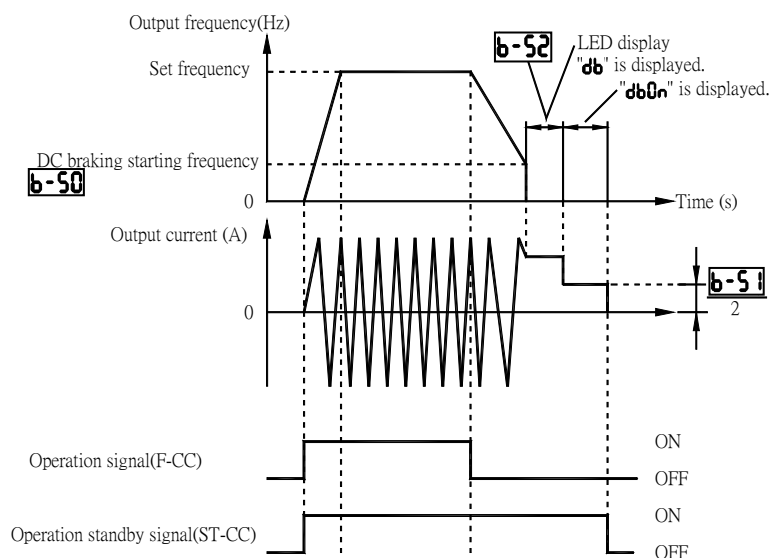

Note 1: About the same motor shaft fixing control can be exercised by entering a DC braking command from external contacts.

Note 2: If a power failure occurs during motor shaft fixing control and the motor starts to coast, motor shaft fixing control will be canceled.

Also, if the inverter trips during motor shaft fixing control and is restored to working order by the retry function, motor shaft fixing control will be canceled.

Note 3: During shaft fixing control, the carrier frequency is 4kHz or less irrespective of the setting of parameter **C-00** (PWM carrier frequency).

## 7.8 Auto-stop in case of lower-limit frequency continuous operation

### 7.8.1 Auto-stop in case of lower-limit frequency continuous operation

#### **b-56 : Auto-stop in case of lower-limit frequency continuous operation**

##### ■ Function

If operation is carried out continuously at a frequency below the lower-limit frequency (**U-11**) for the period of time set with **b-56**, the inverter will automatically slow down the motor to a stop. At that time, "LStP" is displayed (alternately) on the operation panel.

This function will be canceled if a frequency command above the lower-limit frequency (**U-11**) + 0.2Hz.

[Parameter setting]

Title	Function	Adjustment range	Default setting
<b>b-56</b>	Auto-stop in case of lower-limit frequency continuous operation time	0.0: None 0.1-600.0 (sec.)	0.0

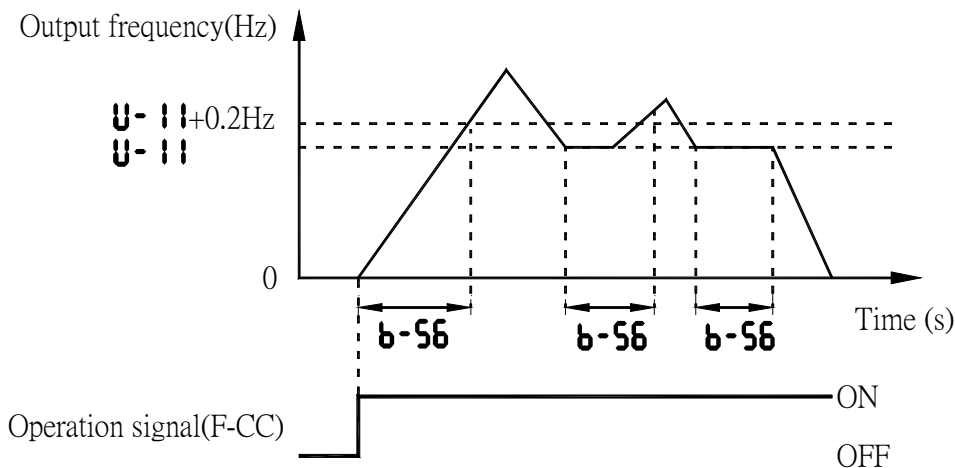

Note: This function is enabled even at the start of operation and during switching between forward and reverse run.

## 7.9 Jog run mode

**b-60** : Jog run frequency  
**b-61** : Jog run stopping pattern  
**b-62** : Panel jog run mode  
**R-13** : Input terminal selection (RES)

### ■ Function

Use the jog run parameters to operate the motor in jog mode. Input of a jog run signal generates a jog run frequency output at once, irrespective of the designated acceleration time.

Also, you can choose an operation panel start/stop mode between the ordinary start/stop mode and the jog run start/stop mode.

The jog run function needs to be assigned to an input terminal. When assigning it to the RES terminal, set **R-13** to **4**.

The motor can be operated in jog mode while the jog run setting terminals are connected (RES-CC ON). (Setting **R-13** to **4**.)

[Parameter setting]

Title	Function	Adjustment range	Default setting
<b>b-60</b>	Jog run frequency	<del>b-40</del> 20.0 (Hz)	5.0
<b>b-61</b>	Jog run stopping pattern	0: Slowdown stop 1: Coast stop 2: DC braking	0
<b>b-62</b>	Panel jog run mode	0: Disabled 1: Panel jog run mode enabled	0

[Setting of jog run setting terminal (RES-CC)]

Assign control terminal RES ([4: reset signal] in default setting) as the jog run setting terminal.

Title	Function	Adjustment range	Default setting
<b>A-13</b>	Input terminal selection (RES)	0 - 65	4 (jog run setting terminal)

Note 1: During the jog run mode, there is LOW (low speed detection signal) output but no RCH (designated frequency reach signal) output, and PID control does not work.

Note 2: When the operation panel only is used for operation in jog run mode, the jog run function does not need to be assigned to any input terminal.

<Examples of jog run>

- RES-CC (JOG) ON+F-CC ON: Forward jog run
- RES-CC (JOG) ON+F-CC ON: Reverse jog run
- Normal operation frequency signal input + F-CC ON: Forward run
- Normal operation frequency signal input +R-CC ON Reverse run

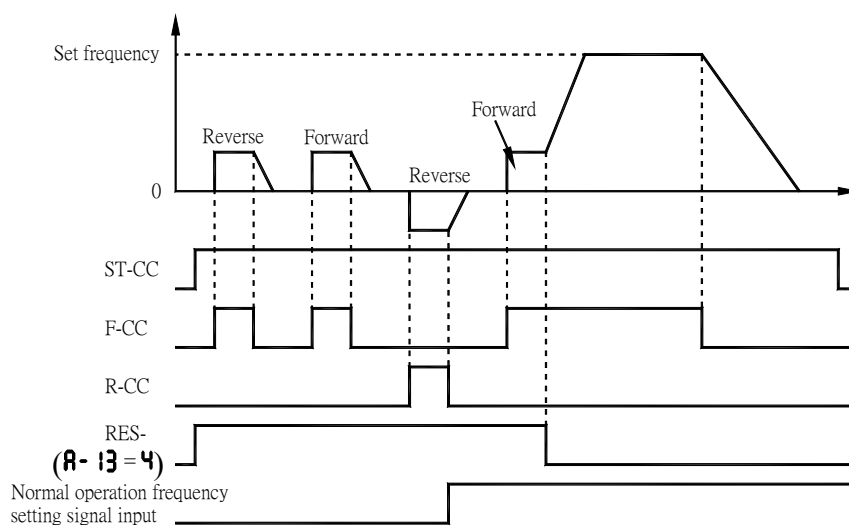











- The jog run setting terminal (RES-CC) is enabled when the operation frequency is below the jog run frequency.

This connection does not function at an operation frequency exceeding the jog run frequency.

- The motor can be operated in jog mode while the jog run setting terminals are connected (RES-CC).
- Jog run has priority, even when a new operation command is given during operation.
- Even for **b-61=0** or **1**, an emergency DC braking becomes enabled when setting **F-03=2**.
- No limits are imposed to the jog run frequency by the upper-limit frequency (parameter **U-10**).

■ Panel jog mode (if **b-62** is set to **1**)

- When the inverter is in panel jog mode, pressing the  key displays **FJOG**, while pressing the  key displays **rJOG**.
- When **FJOG** is displayed, the inverter will be placed in forward jog run mode as long as the  key is held down.
- When **rJOG** is displayed, the inverter will be placed in reverse jog run mode as long as the  key is held down.
- During jog run, the direction of rotation can be changed using the  and  keys. Press the  key to run the motor in the forward direction, or press the  key to run it in the reverse direction.
- If you press and hold down the  key for 20 seconds or more, the key failure alarm “**Er 17**” will be displayed.

Here is the sequence in which modes change each time you press the  key.

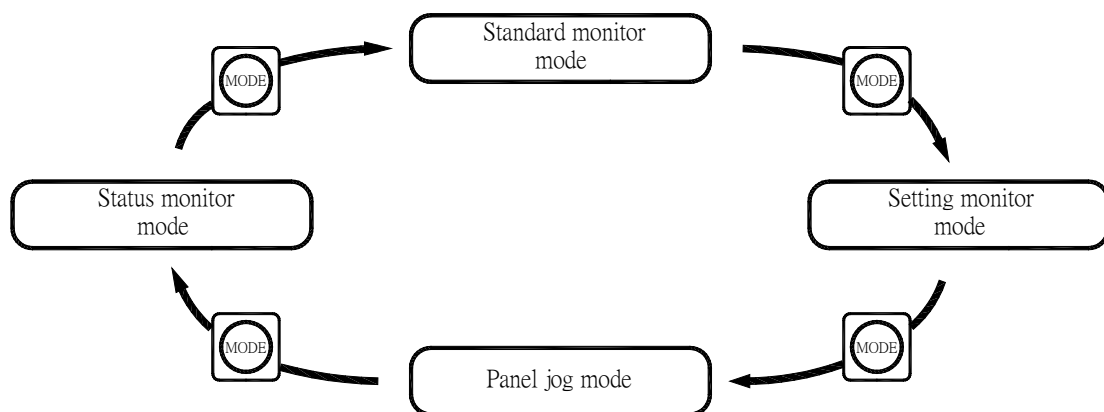

Note: When the inverter is in operation (RUN lamp is blinking) or when an operation command is issued (RUN lamp is lit), the inverter cannot be switched to panel jog mode.

## 7.10 Jump frequency- jumping resonant frequencies

**b-70** : Jump frequency 1  
**b-71** : Jumping width 1  
**b-72** : Jump frequency 2  
**b-73** : Jumping width 2  
**b-74** : Jump frequency 3  
**b-75** : Jumping width 3

### ■ Function

Resonance due to the natural frequency of the mechanical system can be avoided by jumping the resonant frequency during operation. During jumping, hysteresis characteristics with respect to the jump frequency are given to the motor.

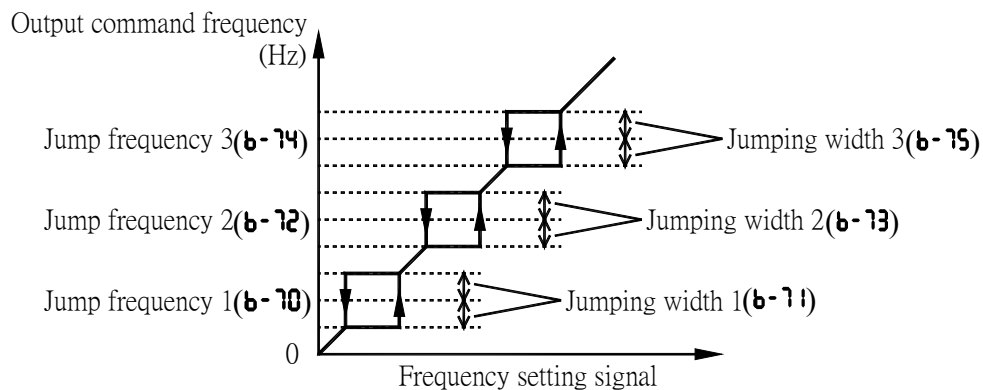

### [Parameter setting]

Title	Function	Adjustment range	Default setting
<b>b-70</b>	Jump frequency 1	0.0 - <b>U-09</b> (Hz)	0.0
<b>b-71</b>	Jumping width 1	0.0-30.0 (Hz)	0.0
<b>b-72</b>	Jump frequency 2	0.0 - <b>U-09</b> (Hz)	0.0
<b>b-73</b>	Jumping width 2	0.0-30.0 (Hz)	0.0
<b>b-74</b>	Jump frequency 3	0.0 - <b>U-09</b> (Hz)	0.0
<b>b-75</b>	Jumping width 3	0.0-30.0 (Hz)	0.0

- ☆ Do not set the jump parameters, if multiple jump frequency setting width overlap.
- ☆ During acceleration or deceleration, the jumping function is disabled for the operation frequency.

## 7.11 Preset-speed operation frequencies

### 7.11.1 Preset-speed operation frequencies 8 to 15

#### **b-87-b-94 :Preset-speed operation frequency 8 to 15**

See section 6.14 (Page 6-30) for details.

### 7.11.2 Fire-speed control

#### **b-94 :Preset-speed operation frequency 15 (fire-speed)**

##### ■ Function

Fire-speed control is used when operating the motor at the specified frequency in case of an emergency. If fire-speed control is assigned to the terminal board selection parameter and a fire-speed control signal is given, the motor will be operated at the frequency specified with **b-94** (preset-speed operation frequency 15). (When the terminal board selection parameter is set to 52 or 53).

## 7.12 PWM carrier frequency

#### **ζ-00 :PWM carrier frequency**

#### **ζ-12 :Random mode**

#### **ζ-16 :Carrier frequency control mode selection**

##### ■ Function

- 1) The **ζ-00** parameter allows the tone of the magnetic noise from the motor to be changed by switching the PWM carrier frequency. This parameter is also effective in preventing the motor from resonating with its load machine or its fan cover.
- 2) In addition, the **ζ-00** parameter reduces the electromagnetic noise generated by the inverter. Reduce the carrier frequency to reduce electromagnetic noise. Note: Although the electromagnetic noise level is reduced, the acoustic noise of the motor is increased.
- 3) The random mode reduces motor electromagnetic noise by changing the pattern of the reduced carrier frequency.

Note: If you are using 600V models by over 40m cable, the carrier frequency (**ζ-00**) should be set preferably below 4kHz.

[Parameter setting]

Title	Function	Adjustment range	Default setting
<b>C-00</b>	PWM carrier frequency	2.0 - 16.0 (kHz) (*)	12.0
<b>C-12</b>	Random mode	0: Disabled, 1: Enabled	0
<b>C-16</b>	Carrier frequency control mode selection	0: Carrier frequency not reduced automatically 1: Carrier frequency reduced automatically 2: Carrier frequency not reduced automatically Support for 48V models 3: Carrier frequency reduced automatically Support for 480V models	1

- Reduction of rated current will be required if the PWM carrier frequency is modified for each applicable motor model. Refer to the following table.
- When the PWM carrier frequency is set high, selecting “Carrier frequency not reduced automatically” causes the inverter to be tripped more easily than selecting “Carrier frequency reduced automatically.”

Reduction of rated current.

[220V Class]

EI-650	Carrier frequency		
	4kHz or less	12kHz or less	16kHz or less
-01L	4.8A	4.4A	4.2A
-02L	8.0A	7.9A	7.1A
-03L	11.0A	10.0A	9.1A
-05L	17.5A	16.4A	14.6A
-07L	27.5A	25.0A	25.0A
-10L	33.0A	33.0A	29.8A
-15L	54.0A	49.0A	49.0A
-20L	66.0A	60.0A	54.0A

[500V Class]

Input voltage	480V or less			More than 480V		
	Carrier frequency			Carrier frequency		
EI-650	4kHz or less	12kHz or less	16kHz or less	4kHz or less	12kHz or less	16kHz or less
-01H	2.3A	2.1A	2.1A	2.1A	1.9A	1.9A
-02H	4.1A	3.7A	3.3A	3.8A	3.4A	3.1A
-03H	5.5A	5.0A	4.5A	5.1A	4.6A	4.2A
-05H	9.5A	8.6A	7.5A	8.7A	7.9A	6.9A
-07H	14.3A	13.0A	13.0A	13.2A	12.0A	12.0A
-10H	17.0A	17.0A	14.8A	15.6A	14.2A	12.4A
-15H	27.7A	25.0A	25.0A	25.5A	23.0A	23.0A
-20H	33.0A	30.0A	26.0A	30.4A	27.6A	24.0A

- \* The currents in the above table are used as the basis to make calculations for inverter overload trip (OL-1).
- \* Default setting of PWM carrier frequency is 12kHz, but rated output current of rating label display at 4kHz. If C-16 is set to 1 or 3, however, the carrier frequency will decrease automatically with increase in current in order to secure the rated current at frequencies of 4 kHz or less.
- \* If C-16 is set to 0 or 2, OCP trip will occur when the current increases and reaches the level above which the carrier frequency is decreased automatically.
- \* Random control is exercised when the motor is operated in a low-frequency range where it produces annoying magnetic noise.  
If the carrier frequency (C-00) is set above 7.1 kHz, the random control function will not be performed, because the level of motor magnetic noise is low at high frequencies.
- \* When the carrier frequency control mode selection (C-16) is set to 2 or 3, the carrier frequency (C-00) should be set preferably below 4 kHz. Otherwise the output voltage may drop.

## 7.13 Trip-less intensification

### 7.13.1 Auto-restart (Restart of coasting motor)

**C-01: Auto-restart control selection**

**⚠ Caution**

 <b>Mandatory</b>	<ul style="list-style-type: none"> <li>■ Stand clear of motors and mechanical equipment If the motor stops due to a momentary power failure, the equipment will start suddenly when power is restored. This could result in unexpected injury.</li> <li>■ Attach warnings about sudden restart after a momentary power failure on inverters, motors and equipment for prevention of accidents in advance.</li> </ul>
---	--

■ **Function**

The **C-01** parameter detects the rotating speed and rotational direction of the motor during coasting in the event of momentary power failure, and then after power has been restored, restarts the motor smoothly (motor speed search function). This parameter also allows commercial power operation to be switched to inverter operation without stopping the motor.

During operation, "rtr9" is displayed.

Title	Function	Adjustment range	Default setting
<b>C-01</b>	Auto-restart control Selection	0: Disabled 1: At auto-restart after momentary stop 2: When turning ST-CC on or off 3: At auto-restart or when turning ST-CC on or off 4: At start-up	0

\* If the motor is restarted in retry mode, this function will operate, regardless of the setting of this parameter.

1) Auto-restart after momentary power failure (Auto-restart function)

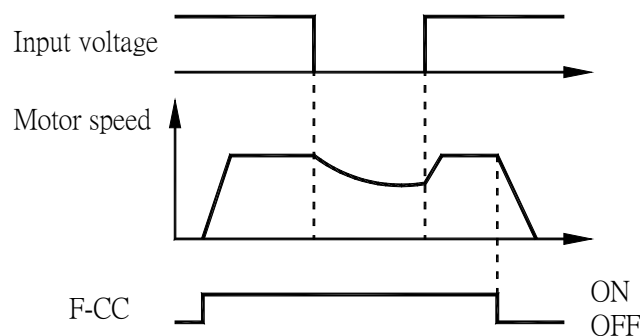

★ Setting **C-01** to **1 (3)**: This function operates after power has been restored following detection of an undervoltage by the main circuits and control power.

## 2) Restarting motor during coasting (Motor speed search function)

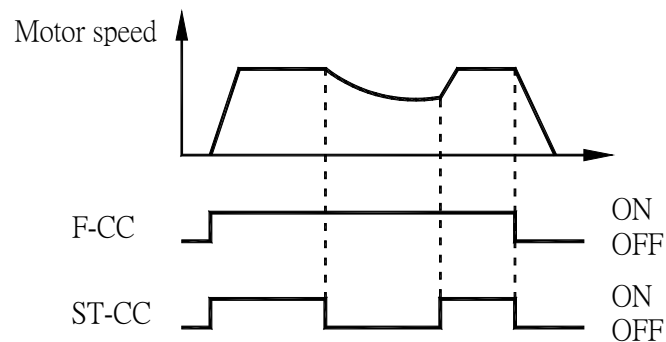

- ★ Setting  $\zeta-01$  to **2** or **3** : This function operates after the ST-CC terminal connection has been opened first and then connected again.

Note: The terminal function ST needs to be assigned to an input terminal, using the parameters **A-11** to **A-18**.

## 3) DC braking during restart

When  $\zeta-01$  is set to **4** , a motor speed search is performed each time operation is started. This function is useful especially when the motor is not operated by the inverter but it is running because of external force.

### Warning!!

- At restart, it takes about 300 ms for the inverter to check to see the number of revolutions of the motor.  
For this reason, the start-up takes more time than usual.
- Use this function when operating a system with one motor connected to one inverter.  
This function may not operate properly in a system configuration with multiple motors connected to one inverter.

#### **Application to a crane or hoist**

**The crane or hoist may have its load moved downward during the above waiting time from input of the operation starting command to the restart of the motor. To apply the inverter to such machines, therefore, set the auto-restart control mode selection parameter to " $\zeta-01 = 0$ " (Disabled), Do not use the retry function, either.**

## 7.13.2 Regenerative power ride-through control/Deceleration stop

### ☒-02 :Regenerative power ride-through control/Deceleration stop

#### ■ Function

- 1) Regenerative power ride-through control continues the operation of the motor by utilizing motor regenerative energy in the event of momentary power failure.
- 2) Slowdown stop in the event of momentary power failure: If a momentary power failure occurs during operation, the inverter stops forcibly. (Deceleration time varies with control.) When operation is stopped, the message “**STOP**” is displayed (alternately) on the operation panel. After the forced stop, the inverter remains static until you put off the operation command momentarily.

#### [Parameter setting]

Title	Function	Adjustment range	Default setting
☒-02	Regenerative power ride-through control / Deceleration stop	0: Disabled 1: Enabled 2: Slowdown stop	0

Note: Even when this parameter is set, the particular load conditions may cause the motor to coast. In this case, use the auto-restart function ☒-01 along with this parameter function.

#### [When power is interrupted]

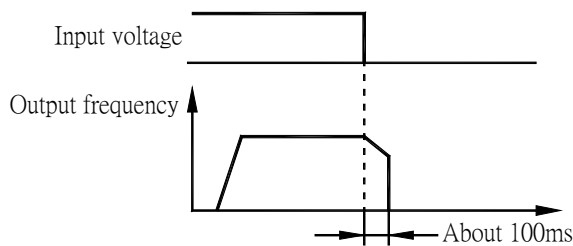

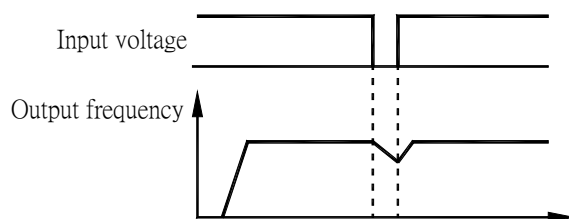

\* The time for which the operation of the motor can be continued depends on the machine inertia and load conditions. Before using this function, therefore, perform verification tests.

#### [If momentary power failure occurs]



### 7.13.3 Retry function

**┌-03 :Retry selection (Selecting the number of times)**

 Caution	
 Mandatory	<ul style="list-style-type: none"> <li>■ Do not go near the motor in alarm-stop status when the retry function is selected. The motor may suddenly restart, which could result in injury.</li> <li>■ Take measures for safety, e.g. attach a cover to the motor, to prevent accidents if the motor suddenly restarts.</li> </ul>

■ Function

This parameter resets the inverter automatically when the inverter gives an alarm. During the retry mode, the motor speed search function operated automatically as required and thus allows smooth motor restarting.

[Parameter setting]

Title	Function	Adjustment range	Default setting
<b>┌-03</b>	Retry selection (number of times)	0: None, 1-10 times	0

The likely causes of tripping and the corresponding retry processes are listed below.

Cause of tripping	Retry process	Canceling conditions
Momentary power failure Overcurrent Overvoltage Overload Overheating	Up to 10 times in succession 1st retry: About 1 sec after tripping 2nd retry: About 2 sec after tripping 3rd retry: About 3 sec after tripping . . . . 10th retry: About 10 sec after tripping	The retry function will be canceled at once if tripping is caused by an unusual event other than: momentary power failure, overcurrent, overvoltage or overload. This function will also be canceled if retrying is not successful within the specified number of times.

★ The retry function is disabled in the following unusual events:

- |  |  |
|--|--|
| <ul style="list-style-type: none"> <li>• <b>OC-R</b> : Am overcurrent at start-up</li> <li>• <b>OC-L</b> : Overcurrent on the load side at start-up</li> <li>• <b>PF-0</b> : Output phase failure</li> <li>• <b>OH-2</b> : External thermal trip</li> <li>• <b>Ot-1</b> : Overtorque trip</li> </ul> | <ul style="list-style-type: none"> <li>• <b>┌PF3</b> : Main unit RAM fault</li> <li>• <b>┌PF4</b> : Main unit ROM fault</li> <li>• <b>┌PF0</b> : CPU fault trip</li> <li>• <b>┌E-1</b> : Remote control error</li> <li>• <b>┌PF8</b> : Current detector fault</li> </ul> |
|--|--|

- **CPF8** : External trip stop
- **CPF9** : Small-current operation trip
- **Uv-1** : Undervoltage trip (main circuit)
- **GF-1** : Ground fault trip
- **PF-1** : Input phase failure
- **OPE2** : Inverter type error
- **OPE1** : Control circuit board format error
- **CPF5** : EEPROM fault 1
- **CPF6** : EEPROM fault 2
- **CPF7** : EEPROM fault 3
- **AtE1** : Auto-tuning error
- **RIE1** : VIA input detection error
- **CE-2** : Main unit CPU communication error
- **OPE3** : Excessive torque boost
- **CPF2** : CPU fault 2

- ★ Protective operation detection relay signals (FLA, FLB, FLC terminal signals) are not sent during use of the retry function. (Default setting)
- ★ To allow a signal to be sent to the protective action detection relay (FLA, B and C terminals) even during the retry process, assign the function 36 or 37 to A-32.
- ★ A virtual cooling time is provided for overload tripping (**OL-1, OL-2, OL-r** ).  
In this case, the retry function operates after the virtual cooling time and retry time.
- ★ In the event of tripping caused by an overvoltage (**Uv-1 - Uv-3**), the retry function will not be activated until the voltage in the DC section comes down to a normal level.
- ★ In the event of tripping caused by overheating (**OH-1** ), the retry function will not be activated until the temperature in the inverter comes down low enough for it to restart operation.
- ★ Keep in mind that when **F-02** is set to **1** (trip retained), the retry function will not be performed, regardless of the setting of **C-03**.
- ★ During retrying, the blinking display will alternate between **rtRY** and the monitor display specified by status monitor display mode selection parameter **H-10**.
- ★ The number of retries will be cleared if the inverter is not tripped for the specified period of time after a successful retry.  
"A successful retry" means that the inverter output frequency reaches the command frequency without causing the inverter to re-trip.

### 7.13.4 Dynamic (regenerative) braking – For abrupt motor stop

**[-04 :Dynamic braking selection**  
**[-08 :Dynamic braking resistance**  
**[-09 :Dynamic braking resistor capacity**

■ Function

The EI-650 does not contain a braking resistor. Connect an external braking resistor in the following cases to enable dynamic braking function:

- 1) when decelerating the motor abruptly or if overvoltage tripping (OP) occurs during deceleration stop
- 2) when a continuous regenerative status occurs during downward movement of a lift or the winding-out operation of a tension control machine
- 3) when the load fluctuates and a continuous regenerative status results even during constant speed operation of a machine such as a press

[Parameter setting]

Title	Function	Adjustment range	Default setting
<b>[-04</b>	Dynamic braking selection	0: Disabled 1: Enabled (Resistor overload protection enabled)	0
<b>[-08</b>	Dynamic braking resistance	1.0-1000 ( $\Omega$ )	Depending on models (See Ch 5,5-21)
<b>[-09</b>	Dynamic braking resistor capacity	0.01-30.00 (kW)	

- 1) Connecting an external braking resistor (optional)  
Separate-optional resistor (with thermal fuse)

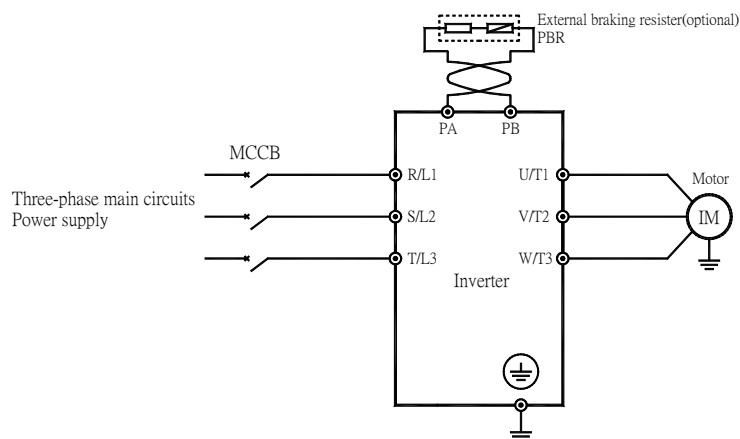

Connecting thermal relays and an external braking resistor

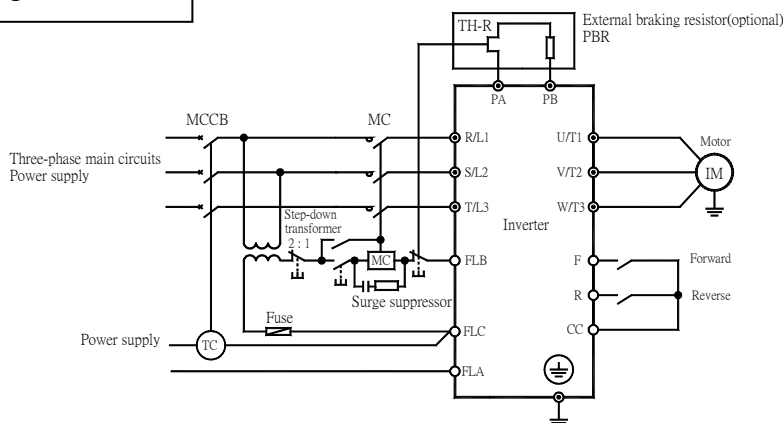

Note 1: A TC (Trip coil) is connected, as shown in this figure, when an MCCB with a trip coil is used instead of an MC. A step-down transformer is needed for every 400V-class inverter, but not for any 200V- class inverter.

Note 2: As a last resort to prevent fire, be sure to connect a thermal relay (THR). Although the inverter has a means of preventing overload and overcurrent to protect the braking resistor, the thermal relay is activated in case the protection function fails to work. Select and connect a thermal relay (THR) appropriate to the capacity (wattage) of the braking resistor.

[Parameter setting]

Title	Function	Default setting
<b>└-04</b>	Dynamic braking selection	1
<b>└-05</b>	Oversvoltage limit operation	1
<b>└-08</b>	Dynamic braking resistance	Any value
<b>└-09</b>	Dynamic braking resistor capacity	Any value

- ☆ To connect a dynamic braking resistor, set the oversvoltage limit operation parameter **└-05** to “1” (Disabled).
- ☆ To use this inverter in applications that create a continuously regenerative status (such as downward movement of a lift, a press or a tension control machine), or in applications that require slowdown stopping of a machine with a significant load inertial moment, increase the dynamic braking resistor capacity according to the operation rate required.
- ☆ To connect an external dynamic braking resistor, select one with a resultant resistance value greater than the minimum allowable resistance value. Be sure to set the appropriate operation rate in **└-08** and **└-09** to ensure overload protection.

☆ When using a braking resistor with no thermal fuse, connect and use a thermal relay as a control circuit for cutting power off.

## 2) Optional dynamic braking resistors

Optional dynamic braking resistors are listed below. All these resistors are 3%ED in operation rate.

Inverter type	Braking resistor
	Rating
EI-650-01L	120W-200Ω
EI-650-02L ~ 03L	120W-75Ω
EI-650-05L	120W-40Ω
EI-650-07L	240W-20Ω(120W-40Ωx2P)
EI-650-10L	440W-15Ω(220W-30Ωx2P)
EI-650-15L	660W-10Ω(220W-30Ωx3P)
EI-650-20L	880W-7.5Ω(220W-30Ωx4P)
EI-650-01H ~ 03H	120W-200Ω
EI-650-05H	120W-160Ω
EI-650-07H	240W-80Ω(120W-160Ωx2P)
EI-650-10H	440W-60Ω(220W-120Ωx2P)
EI-650-15H	660W-40Ω(220W-120Ωx3P)
EI-650-20H	880W-30Ω(220W-120Ωx4P)

Note 1: The data in Rating above refer to the resultant resistance capacities (watts) and resultant resistance values (Ω).

The numeric values inside parentheses refer to the internal compositions of resistors.

Note 2: Braking resistors for frequent regenerative braking are optionally available. For more information, contact your nearest Rich inverter distributor.

## 3) Minimum resistances of connectable braking resistors

The minimum allowable resistance values of the externally connectable braking resistors are listed in the table below.

Do not connect braking resistors with smaller resultant resistances than the listed minimum allowable resistance values.

Inverter rated output capacity (HP)	[240V Class]		[480V Class]	
	Resistance of standard option	Minimum allowable resistance	Resistance of standard option	Minimum allowable resistance
1	200Ω	55Ω	200Ω	114Ω
2	75Ω	44Ω	200Ω	67Ω
3	75Ω	33Ω	200Ω	67Ω
5	40Ω	16Ω	160Ω	54Ω
7.5	20Ω	12Ω	80Ω	43Ω
10	15Ω	12Ω	60Ω	28Ω
15	10Ω	5Ω	40Ω	16Ω
20	7.5Ω	5Ω	30Ω	16Ω

Note: Be sure to **Ⓢ-08** (Dynamic braking resistance) at the resistance of the dynamic braking resistor connected.

### 7.13.5 Avoiding overvoltage tripping

**Ⓢ-05 :Overvoltage limit operation**

**F-26 :Overvoltage stall protection level**

#### ■ Function

These parameters are used to keep the output frequency constant or increase it to prevent overvoltage tripping in case the voltage in the DC section rises during deceleration or varying speed operation. The deceleration time during overvoltage limit operation may increase above the designated time.

Overvoltage limit operation level

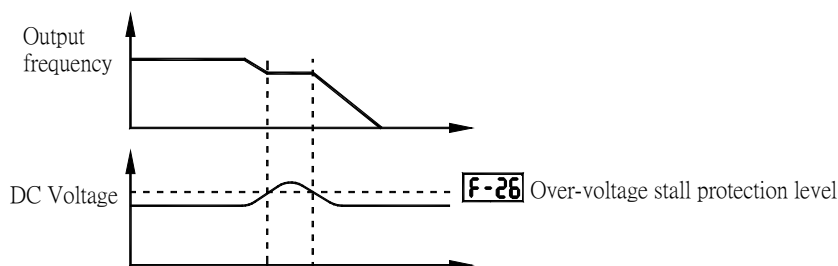

[Parameter setting]

Title	Function	Adjustment range	Default setting
<b>ƒ-05</b>	Overvoltage limit operation (Slowdown stop mode selection)	0: Enabled 1: Disabled 2: Enabled (Quick deceleration) 3: Enabled (Dynamic quick deceleration)	2
<b>F-26</b>	Overvoltage limit operation level	100-150%	240V Models: 134% 480V models: 140%

- ☆ If **ƒ-05** is set to **2** (quick deceleration), the inverter will increase the voltage to the motor (over-excitation control) to increase the amount of energy consumed by the motor when the voltage reaches the overvoltage protection level, and therefore the motor can be decelerated more quickly than normal deceleration.
- ☆ If **ƒ-05** is set to **3** (dynamic quick deceleration), the inverter will increase the voltage to the motor (over-excitation control) to increase the amount of energy consumed by the motor as soon as the motor begins to slow down, and therefore the motor can be decelerated still more quickly than quick deceleration.

### 7.13.6 Output voltage adjustment / Supply voltage correction

**U-13** :Base frequency voltage 1  
**ƒ-07** :Supply voltage correction (output voltage adjustment)

■ Function

**Base frequency voltage 1**

The **ƒ-07** parameter adjusts the voltage corresponding to the base frequency 1 **U-10** so that no voltage exceeding the **U-13** set value is put out. (This function is enabled only when **ƒ-07** is set to either “0” or “1”.)

**Supply voltage correction**

The **ƒ-07** parameter maintains a constant V/F ratio, even when the input voltage decreases. The torque during low-speed operation is prevented from decreasing.

Maintains a constant V/F ratio, even when the input voltage fluctuates.

Output voltage adjustment ..... Limits the voltage at frequencies exceeding the base frequency. Applied when operating a special motor with low induced voltage.

[Parameter setting]

Title	Function	Adjustment range	Default setting
<b>U-13</b>	Base frequency voltage	50-330 (V) : 240V class 50-660 (V) : 480V class	230 (240V class) 460 (480V class)
<b>C-07</b>	Supply voltage correction (output voltage limited)	0: Supply voltage uncorrected, output voltage limited 1: Supply voltage corrected, output voltage limited 2: Supply voltage uncorrected, output voltage unlimited 3: Supply voltage corrected, output voltage unlimited	2

- ☆ If **C-07** is set to “**0**” or “**2**”, the output voltage will change in proportion to the input voltage.
- ☆ Even if the base frequency voltage (**U-13** parameter) is set above the input voltage, the output voltage will not exceed the input voltage.
- ☆ The rate of voltage to frequency can be adjusted according to the rated motor capacity. For example, setting **C-07** to “**0**” or “**1**” prevents the output voltage from increasing, even if the input voltage changes when operation frequency exceeds the base frequency.
- ☆ When the V/F control mode selection parameter (**U-14**) is set to any number between **2** and **6**, the supply voltage is corrected regardless of the setting of **C-07**.

[0:Supply voltage uncorrected, output voltage limited]

[1:Supply voltage corrected, output voltage limited]

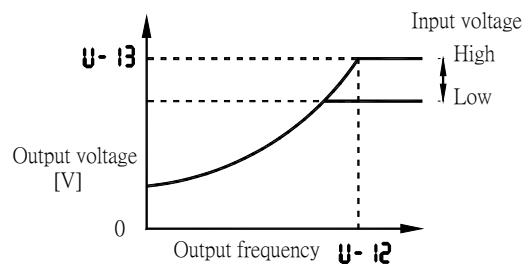
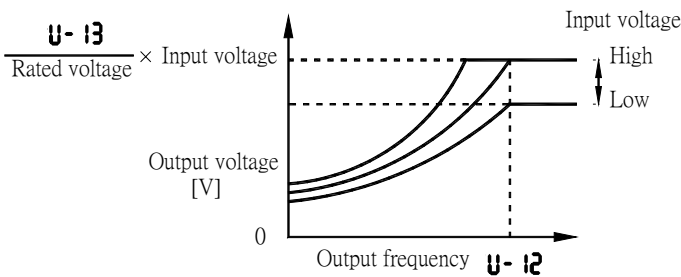

\* The above applies when V/F control mode selection parameter **U-14** is set to “**0**” or “**1**”.

$\frac{\text{U-13}}{\text{Rated voltage}} >$  the output voltage can be prevented from exceeding the input voltage.

[2: Supply voltage uncorrected, output voltage unlimited]

[3: Supply voltage corrected, output voltage unlimited]

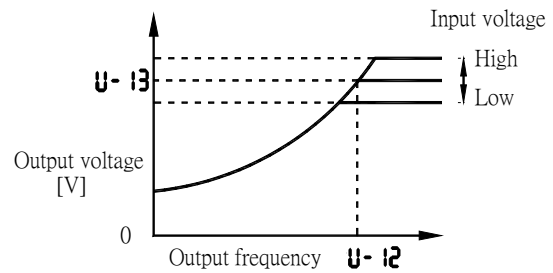
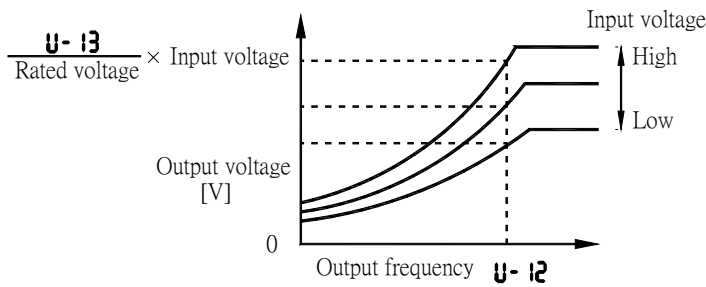

\* The above applies when V/F control mode selection parameter **U-14** is set to “0” or “1”.

\* Even if **U-13** is set for an output voltage lower than the input voltage, the output voltage will exceed the voltage adjusted by **U-13** when the output frequency is higher than the base frequency **U-12**.

$\frac{U-13}{\text{Rated voltage}}$  → the output voltage can be prevented from exceeding the input voltage.

### 7.13.7 Canceling the operation command

#### [-11]: Reverse-run prohibition

##### ■ Function

This function prevents the motor from running in the forward or reverse direction when it receives the wrong operation signal.

[Parameter setting]

Title	Function	Adjustment range	Default setting
<b>[-11]</b>	Reverse-run prohibition	0: Forward/reverse run permitted 1: Reverse run prohibited 2: Forward run prohibited	0

## 7.14 Droop control

#### [-20]: Droop gain

#### [-23]: Droop insensitive torque band

##### ■ Function

Droop control has the function of preventing loads from concentrating at a specific motor because of a load imbalance when multiple inverters are used to operate one machine.

These parameters are used to allow the motor to “slip” according to the load torque current. Using these parameters, the insensitive torque band and the gain can be adjusted.

[Parameter setting]

Title	Function	Adjustment range	Default setting
<b>└-20</b>	Droop gain	0-100%	0%
<b>└-23</b>	Droop insensitive torque band	0-100%	10%

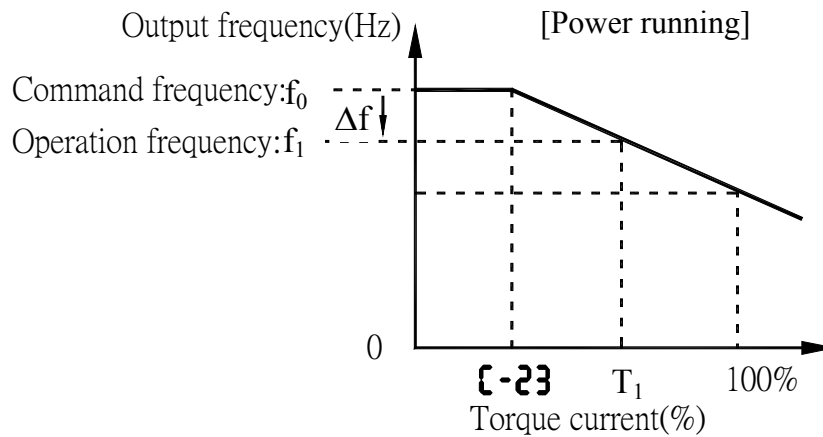

☆ The droop control function refers to the function of operating the power-running motor at operating frequency  $f_1$  (Hz) that is lower than command frequency  $f_0$  (Hz) by droop frequency  $\Delta f$  (Hz) when the torque current is  $T_1$  (%). (See the above figure.)

- The droop frequency  $\Delta f$  can be calculated, using the following expression.

Droop frequency  $\Delta f$  (Hz) = base frequency  $\boxed{\text{U-10}}$   $\times$  **└-20**  $\times$  (Torque current  $T_1$  - **└-23**)

- When the torque current is above the specified droop insensitive torque band (**└-23**), the frequency is reduced during power running or increased during regenerative braking. The above figure shows an example of the operating frequency during power running. During regenerative braking, control is performed in such a way as to increase the frequency.
- The droop function is activated above the torque current set with **└-23**.
- The amount of droop frequency  $\Delta f$  varies depending on the amount of torque current  $T_1$ .

Note: If the base frequency **U-10** exceeds 100Hz, count it as 100Hz.

Control is exercised between the starting frequency (**b-40**) and the maximum frequency (**U-09**).

[An example of calculation]

Parameter setting: Base frequency **U-10** = 60 (Hz), droop gain **└-20** = 10 %

Droop insensitive torque band **└-23** = 30 (%)

Droop frequency  $\Delta f$  (Hz) and operating frequency  $f_1$  when command frequency  $f_0$  is 50 (Hz) and torque current  $T_1$  is 100 (%) are as follows.

$$\begin{aligned} \text{Droop frequency } \Delta f \text{ (Hz)} &= 0.10 \times [C-20] \times (T_1 - [C-23]) \\ &= 60 \text{ (Hz)} \times 10 \text{ (\%)} \times (100 \text{ (\%)} - 30 \text{ (\%)})) \\ &= 4.2 \text{ (Hz)} \end{aligned}$$

$$\text{Operation frequency } f_1 \text{ (Hz)} = f_0 - \Delta f = 50 \text{ (Hz)} - 4.2 \text{ (Hz)} = 45.8 \text{ (Hz)}$$

## 7.15 Braking setting functions

[C-42] :Braking mode selection  
 [C-43] :Release frequency  
 [C-44] :Release time  
 [C-45] :Creeping frequency  
 [C-46] :Creeping time

### ■ Function

Setting functions to control braking timing.

Note: For these parameters, contact your nearest Rich inverter distributor.

## 7.16 Conducting PID control

[C-59] :PID control waiting time  
 [C-60] :PID control  
 [C-62] :Proportional gain  
 [C-63] :Integral gain  
 [C-66] :Differential gain

### ■ Function

Using feedback signals (4 to 20mA, 0 to 10V) from a detector, process control can be exercised, for example, to keep the airflow, amount of flow or pressure constant.

[Parameter setting]

Title	Function	Adjustment range	Default setting
[C-59]	PID control waiting time	0-2400 [sec]	0
[C-60]	PID control	0: Disabled, 1: Enabled	0
[C-62]	Proportional gain	0.01-100.0	0.30
[C-63]	Integral gain	0.01-100.0	0.20
[C-66]	Differential gain	0.00-2.55	0.00

## 1) External connection

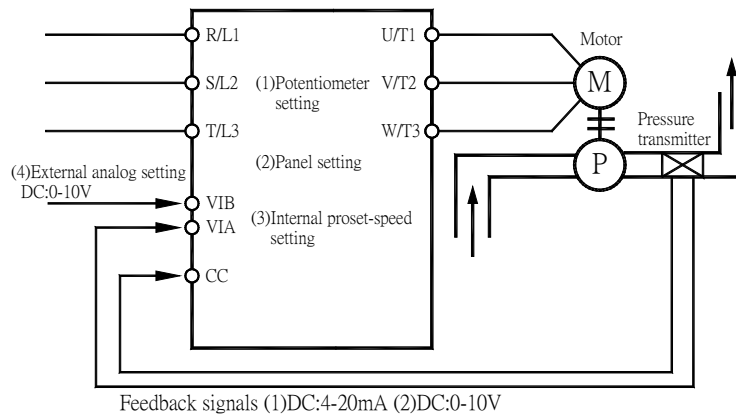

## 2) Types of PID control interfaces

Process quantity input data (frequency) and feedback input data can be combined as follows for the PID control of the EI-650:

Process quantity input data (frequency setting)		Feedback input data
Setting method	Frequency setting mode selection 1 <b>U-02 / b-07 / b-00</b>	
(1) Internal potentiometer setting	<b>0</b>	External analog input VIA (DC:4-20V / DC:0-10V)
(2) Panel input setting	<b>3</b>	
(3) Internal preset-speed setting	<b>-(U-01=0)</b>	
(4) External analog setting VIB (DC:0-10V)	<b>2</b>	

Note 1: About the setting of **U-02, b-07** and **b-00** : Do not enable VIA using these parameters, because the VIA terminal is used for feedback signals.

Note 2: To make the inverter send out a signal that indicates whether the amount of feedback agree with (or reaches) the amount of processing, assign the function 52 or 53 to an unassigned output terminal. You can also specify a frequency agreement detection range (**A-67**). For more information. See 7.3.4 (Page 7-11)

## 3) Setting PID control

Set “1” in the extended parameter **C-60** (PID control)

- (1) Set parameters **U-07** (acceleration time), and **U-08** (deceleration time) to the system fitting values.
- (2) To limit the output frequency, set parameters **U-10** (upper limit frequency) and **U-11** (lower limit frequency). If process quantities are set from the operation panel, however, the process quantity setting range will be limited by the settings of **U-10** and **U-11**.

#### 4) Adjusting the PID control gain level

Adjust the PID control gain level according to the process quantities, the feedback signals and the object to be controlled.

The following parameters are provided for gain adjustment:

Parameter	Setting range	Default setting
<b>└-62</b> (P-gain)	0.01-100.0	0.30
<b>└-63</b> (I-gain)	0.01-100.0	0.20
<b>└-66</b> (D-gain)	0.00-2.55	0.00

#### **└-62** (P-gain adjustment parameter)

This parameter adjusts the proportional gain level during PID control. A correction value proportional to the particular deviation (the difference between the set frequency and the feedback value) is obtained by multiplying this deviation by the parameter setting.

A larger P-gain adjustment value gives faster response. Too large an adjustment value, however, results in an unstable event such as hunting.

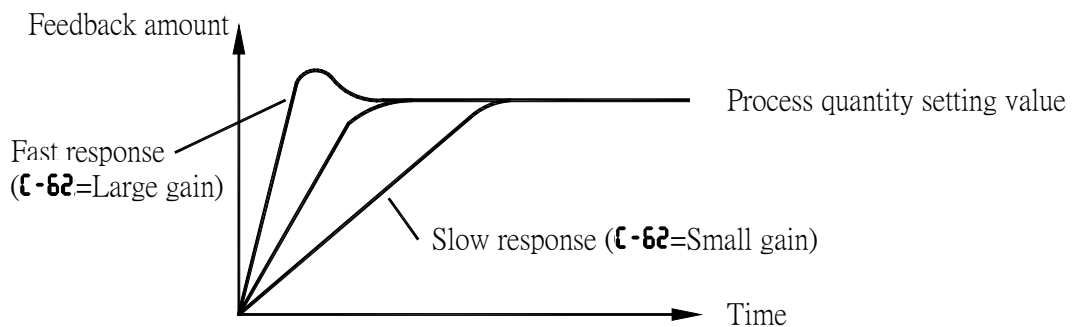

#### **└-63** (I-gain adjustment parameter)

This parameter adjusts the integral gain level during PID control. Any deviations remaining unremoved during proportional action are cleared to zero (residual deviation offset function).

A larger I-gain adjustment value reduces residual deviations. Too large an adjustment value, however, results in an unstable event such as hunting.

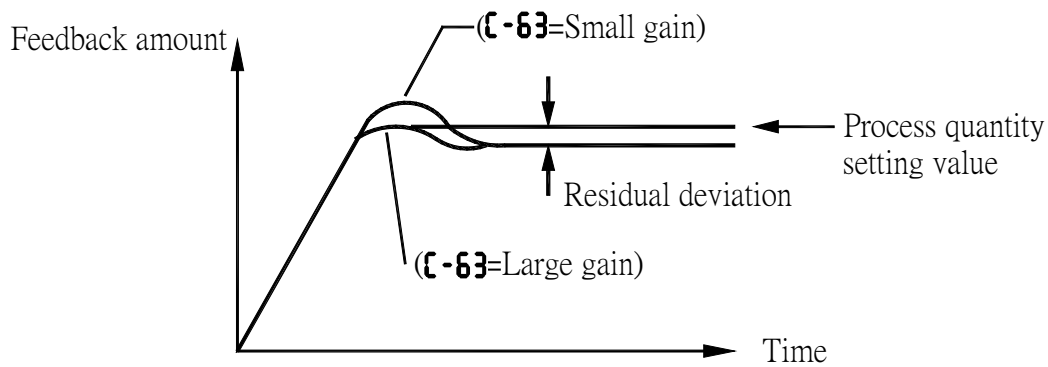

☆ If one of input terminals is assigned input terminal function 65 (PID control integral value clear), integral value is always 0 (zero) during the input terminal on.

### C-66 (D-gain adjustment parameter)

This parameter adjusts the differential gain level during PID control. This gain increases the speed of response to a rapid change in deviation (difference between the frequency setting and the amount of feedback).

Note that setting the gain more than necessary may cause great fluctuations in output frequency, and thus operation to become unstable.

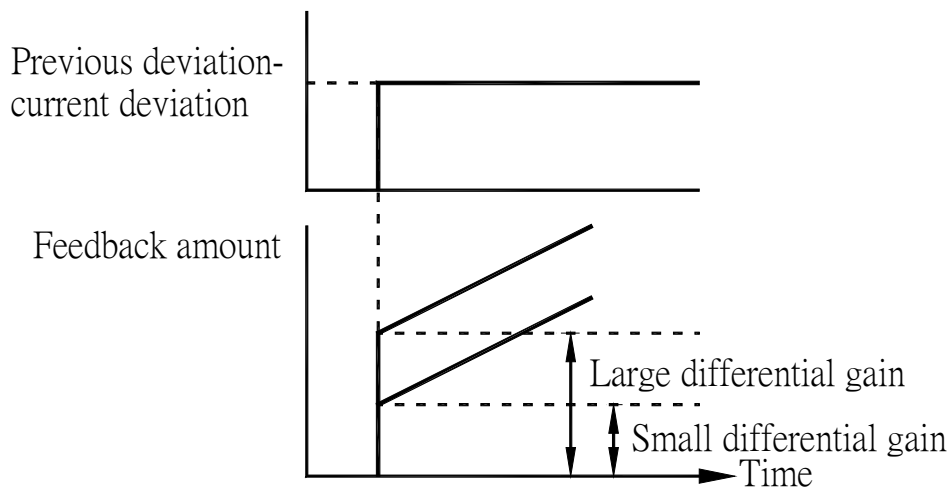

### 5) Adjusting analog command voltages

To use external analog setting (VIB) or feedback input (VIA), perform voltage-scaling adjustments (input point setting) as required. See Section 7.5.2 (Page 7-19) for further details. If the feedback input data is too small, voltage-scaling adjustment data can also be used for gain adjustment.

Example of VIB terminal setting

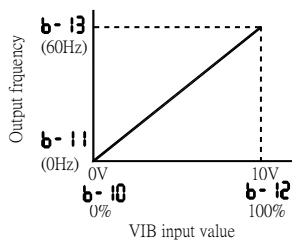

Example of VIA terminal setting (voltage input)

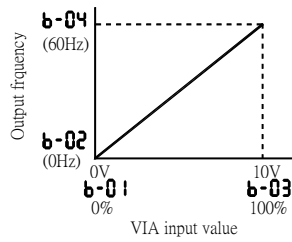

Example of VIA terminal setting (current input)

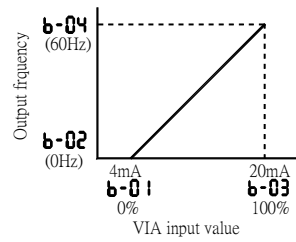

## 6) Setting the time elapsed before PID control starts

You can specify a waiting time for PID control to prevent the inverter from starting PID control before the control system becomes stable, for example, after start-up.

The inverter ignores feedback input signals, carries out operation at the frequency determined by the amount of processing for the period of time specified with **ζ-59** and enters the PID control mode after a lapse of the specified time.

## 7.17 Setting motor constants

### 7.17.1 Setting motor constants 1

**δ-00 :Auto-tuning**  
**δ-01 :Slip frequency gain**  
**δ-02 :Automatic torque boost value**  
**δ-15 :Motor rated current**  
**δ-16 :Motor no-load current**  
**δ-17 :Motor rated speed**  
**δ-18 :Speed control response coefficient**  
**δ-19 :Speed control stable coefficient**

To use vector control, automatic torque boost and automatic energy saving, motor constant setting (motor tuning) is required. The following three methods are available to set motor constants.

- 1) Using the torque boost setting macro function (**CU-2**) for setting the V/F control mode selection (**U-14**) and auto-tuning (**δ-00**) at the same time
- 2) Setting V/F control mode selection (**U-14**) and auto-tuning (**δ-00**) independently
- 3) Combining the V/F control mode selection (**U-14**) and manual tuning

☆ Check to be sure that the setting of the parameter **U-10** and that of the parameter **U-13** agree with the base frequency (rated rotational speed) and base frequency voltage (rated voltage) of the motor to be operated, respectively. If not, set the parameters correctly.

- ☆ When using the inverter to control the operation of a motor smaller in capacity by one grade or more, be sure to set the motor rated current setting parameter ( **d-15** ) properly.
- ☆ Vector control may not operate properly if the motor capacity differs from the applicable rated capacity of the inverter by more than two grades.  
If current waveforms oscillate during operation, increase the speed control stability factor ( **d-19** ). This is effective in suppressing oscillation.

[Selection 1: Setting by parameter setting macro torque boost]

This is the easiest of the available methods. It conducts vector control and auto-tuning at the same time.

Set **CU-2** to **1**  
(Automatic torque boost + auto-tuning)

Set **CU-2** to **2**  
(Vector control + auto-tuning).

Set **CU-2** to **3**  
(Energy-saving + auto-tuning).

See Section 6.2 for details of the method.

[Selection 2: Setting vector control and auto-tuning independently]

This method sets sensorless vector control or automatic boost, and auto-tuning independently. Specify the control mode selection parameter ( **U-14** ) and then set auto-tuning.

Set the auto-tuning parameter **d-00** to **2**  
(Auto-tuning enabled).

[Parameter setting]

Title	Function	Adjustment range	Default setting
<b>d-00</b>	Auto-tuning	0: Auto-tuning disabled (use of internal parameters) 1: Application of individual settings of <b>d-02</b> (after execution: 0) 2: Auto-tuning enabled (after execution: 0)	0

Set **d-00** to **2** to before the start of operation. Tuning is performed at the start of the motor.

☆ Precautions on auto-tuning

- (1) Conduct auto-tuning only after the motor has been connected and operation completely stopped.

If auto-tuning is conducted immediately after operation stops, the presence of a residual voltage may result in abnormal tuning.

- (2) Voltage is applied to the motor during tuning even though it barely rotates. During tuning, “**ALn I**” is displayed on the operation panel.
- (3) Tuning is performed when the motor starts for the first time after **d-00** is set to **2**. Tuning is usually completed within three seconds. If it is aborted, the motor will trip with the display of **ALn I** and no constants will be set for that motor.
- (4) High-speed motors, high-slip motors or other special motors cannot be auto-tuned. For these motors, perform manual tuning using Selection 3 described below.
- (5) Provide cranes and hoists with sufficient circuit protection such as mechanical braking. Without sufficient circuit protection, the resulting insufficient motor torque during tuning could create a risk of machine stalling/falling.
- (6) If auto-tuning is impossible or an “**ALn I**” auto-tuning error is displayed, perform manual tuning with Selection 3.
- (7) If the inverter is tripped during auto-tuning because of an output phase failure (**PF-0**), check if the inverter is connected to the correctly. A check for output phase failures is made during auto-tuning, regardless of the setting of the output phase failure detection mode selection parameter (**F-05**)

[Selection 3: Setting vector control and manual tuning independently]

If an “**ALnE**” tuning error is displayed during auto-tuning or when vector control characteristics are to be improved, independent motor constants can be set.

Title	Function	Adjustment range	Default setting
<b>d-01</b>	Slip frequency gain	0-150 (%)	50
<b>d-02</b>	Automatic torque boost value	0.0-30.0 (%)	Depends on the capacity (See Chapter 5, Page 5-21)
<b>d-15</b>	Motor rated current	0.1-100.0 (A)	
<b>d-16</b>	Motor no-load current	10-90 (%)	
<b>d-17</b>	Motor rated rotational speed	100-32000 (min <sup>-1</sup> )	1410
<b>d-18</b>	Speed control response coefficient	1-150	40
<b>d-19</b>	Speed control stability coefficient	1-100	20
<b>U-16</b>	Motor electronic thermal protection level 1	10-100 (%) / (A)	100

Setting procedure Adjust the following parameters:

- d-01:** Set the compensation gain for the slipping of the motor. A higher slip frequency reduces motor slipping correspondingly. After setting **d-17**, set **d-01** to adjust in detail.
- d-02:** Adjust the primary resistive component of the motor. Decreases in torque due to a possible voltage drop during low-speed operation can be suppressed by setting a large value in this parameter. (Perform adjustments according to the actual operation.)
- d-15:** Set the rated current of the motor. For the rated current, see the motor's nameplate or test report.
- d-16:** Set the ratio of the no-load current of the motor to the rated current. Enter the value in % that is obtained by dividing the no-load current specified in the motor's test report by the rated current.
- d-17:** Set the rated rotational speed of the motor. For the rated current, see the motor's nameplate or test report.
- d-18:** Using this parameter along with **d-19**, adjust the speed of response to the frequency command.
- d-19:** Using this parameter along with **d-18**, adjust the speed of response to the frequency command.

- \* How to make adjustments according to the moment of inertia of the load  
 The moment of inertia of the load (including that of the motor shaft) was set at the factory on the assumption that it would be three times as large as that of the motor shaft.  
 If this assumption does not hold, calculate the values to be entered in **d-18** and **d-19**, using the following equations.

$$\mathbf{d-18} = 40 \times \sqrt{a/3}$$

$$\mathbf{d-19} = 20 \times \sqrt{a/3}$$

Where *a* is the times by which the moment of inertia of the load is larger than that of the motor. After the above adjustments, if necessary, make fine adjustments as described below.

- To increase the response speed: Increase the setting of **d-18**.
- To reduce the response speed: Decrease the setting of **d-18**.
- If overshooting or hunting occurs: Increase the setting of **d-19**.
- If reduction gears or the like squeak: Increase the setting of **d-19**.
- If an over-voltage trip occurs on completion of acceleration: Increase the setting of **d-19**.

When making the above adjustments, increase or decrease settings in steps of 10% or so while checking how things change.

Note also that, depending on the settings of **d-18** and **d-19**, the frequency may exceed the upper-limit frequency if the inverter is set so as to accelerate the load in the shortest possible time.

**U-16**: If the rated capacity of the motor is one size smaller than that of the inverter, lower the thermal protective level according to the rated current of the motor.

- \* Sensorless vector control may not operate properly if the motor capacity differs from the applicable rated capacity of the inverter by more than two grades.

### 7.17.2 Setting motor constants 2 (Details)

**d-80** :Exciting current coefficient  
**d-85** :Stall prevention control coefficient 1  
**d-92** :Stall prevention control coefficient 2  
**d-94** :Motor adjustment coefficient

※ The following parameters enables you to make adjustments more finely.

Title	Function	Adjustment range	Default setting
<b>d-80</b>	Exciting current coefficient	100-130 (%)	100
<b>d-85</b>	Stall prevention control coefficient 1	10-250	100
<b>d-92</b>	Stall prevention control coefficient 2	50-150	100
<b>d-94</b>	Motor adjustment coefficient	0-200	Depends on the capacity

**d-80**: Used to fine adjust the magnetic field increase rate in low-speed range. To increase the torque in low-speed range, specify a larger value for **d-80**. Note that this parameter should be adjusted only when enough torque cannot be obtained, even though auto-tuning (**d-00=2**) was made after the setting of the parameters **d-01** through **d-19**. Note also that adjusting this parameter may cause an increase in the no-load current in low-speed range. If the no-load current exceeds the rated current, do not adjust this parameter.

**d-85**: Using this parameter along with **d-92** adjusts characteristics in a region in which the frequency is above the base frequency (region where the field is weak).

**d-92**: Using this parameter along with **d-85** adjusts characteristics in a region in which the frequency is above the base frequency (region where the field is

weak).

- \* How to make adjustments in a region (region where magnetic field is weak) above the base frequency

If a heavy load is applied instantaneously (or transiently), the motor may stall before the load current reaches the current set with the stall prevention level 1 parameter (**F-01**). In many cases, this kind of stall can be avoided by gradually reducing the setting of **d-85**.

A drop in supply voltage may cause fluctuations of the load current or vibration of the motor. In some cases, such phenomena can be eliminated by changing the setting of **d-92** to between 80 and 90. However, this may cause an increase in load current, so that it is also necessary to adjust the setting of the electronic thermal protective level 1 parameter (**U-16**) properly according to the motor capacity.

- d-94**: There is no need to adjust this parameter under normal conditions. (Do not change the setting, unless otherwise instructed by Rich technical staff)

## 7.18 Acceleration / deceleration patterns 2 and 3

### 7.18.1 Selecting an acceleration / deceleration pattern

**E-02** :Acceleration / deceleration 1 pattern  
**E-06** :S-pattern lower-limit adjustment amount  
**E-07** :S-pattern upper-limit adjustment amount

#### ■ Function

These parameters allow you to select an acceleration / deceleration pattern that suits the intended use.

Title	Function	Adjustment range	Default setting
<b>E-02</b>	Acceleration/ deceleration 1 pattern	0: Linear, 1: S-pattern 1, 2: S-pattern 2	0
<b>E-06</b>	S-pattern lower-limit adjustment amount	0-50%	10%
<b>E-07</b>	S-pattern upper-limit adjustment amount	0-50%	10%

1) Linear acceleration/deceleration  
 A general acceleration/  
 deceleration pattern.  
 This pattern can usually be used.

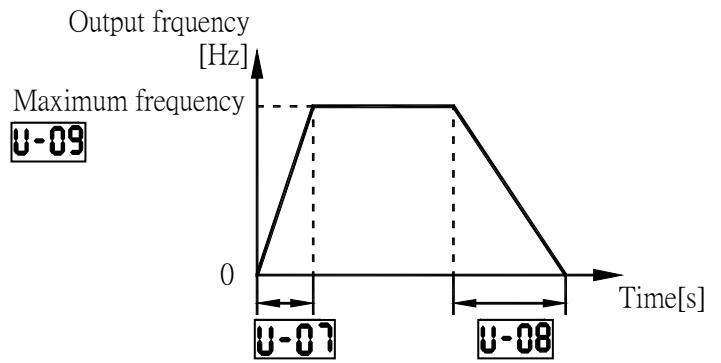

2) S-pattern acceleration / deceleration 1  
 Select this pattern to accelerate /  
 decelerate the motor rapidly to a  
 high-speed region with an output  
 frequency of 60Hz or more or to  
 minimize the shocks applied during  
 acceleration / deceleration.  
 This pattern is suitable for pneumatic  
 transport machines.

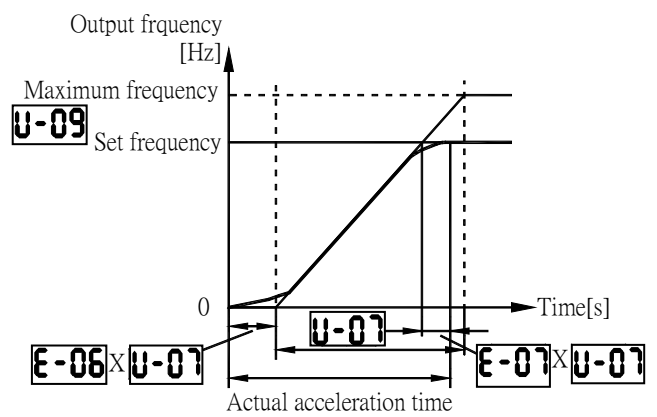

3) S-pattern acceleration / deceleration  
 Select this pattern to obtain slow  
 acceleration in a demagnetizing region  
 with a small motor acceleration torque.  
 This pattern is suitable for high-speed  
 spindle operation.

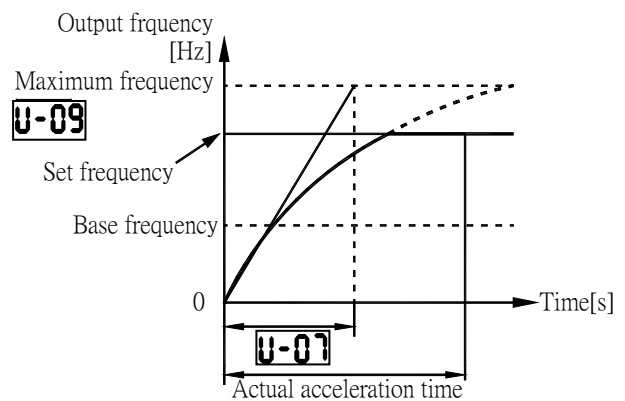

## 7.18.2 Selecting an acceleration / deceleration pattern

**ε-00** :Acceleration time 2  
**ε-01** :Deceleration time 2  
**ε-03** :Acceleration / deceleration 2 pattern  
**ε-04** :Selecting an acceleration / deceleration pattern  
**ε-05** :Acceleration / deceleration 1 and 2 switching frequency  
**ε-10** :Acceleration time 3  
**ε-11** :Deceleration time 3  
**ε-12** :Acceleration / deceleration 3 pattern  
**ε-13** :Acceleration / deceleration 2 and 3 switching frequency

### ■ Function

Three acceleration times and three deceleration times can be specified individually. A method of selection or switching can be selected from among the following:

- 1) Selection by means of parameters
- 2) Switching by changing frequencies
- 3) Switching by means of terminals

Title	Function	Adjustment range	Default setting
<b>ε-00</b>	Acceleration time 2	0.0-3200 [sec]	10.0
<b>ε-01</b>	Deceleration time 2	0.0-3200 [sec]	10.0
<b>ε-04</b>	Selecting an acceleration/deceleration pattern	1: Acc / dec 1 2: Acc / dec 2 3: Acc / dec 3	1
<b>ε-10</b>	Acceleration time 3	0.0-3200 [sec]	10.0
<b>ε-11</b>	Deceleration time 3	0.0-3200 [sec]	10.0

1) Selection using parameters

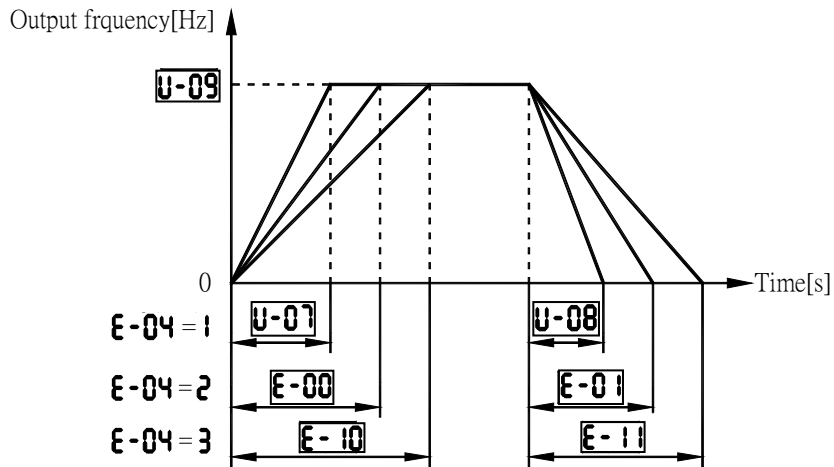

Acceleration/deceleration time 1 is initially set as the default.

Acceleration/deceleration time 2 and 3 can be selected by changing the setting of the **E-04**.

Enabled if **U-01=1** (panel input enabled)

- 1) Switching by frequencies - Switching the acceleration/deceleration time automatically at the frequency setting of **E-05**.

Title	Function	Adjustment range	Default setting
<b>E-05</b>	Acceleration/deceleration 1 and 2 switching frequency	0.0 - <b>U-10</b>	0.0
<b>E-13</b>	Acceleration/deceleration 2 and 3 switching frequency	0.0 - <b>U-10</b>	0.0

Note: Acceleration/deceleration patterns are changed from pattern 1 to pattern 2 and from pattern 2 to pattern 3 in increasing order of frequency, regardless of the order in which frequencies are changed. (For example, if **E-05** is larger than **E-13**, **E-13** pattern 1 is selected in the frequency range below the frequency set with **E-05**.)

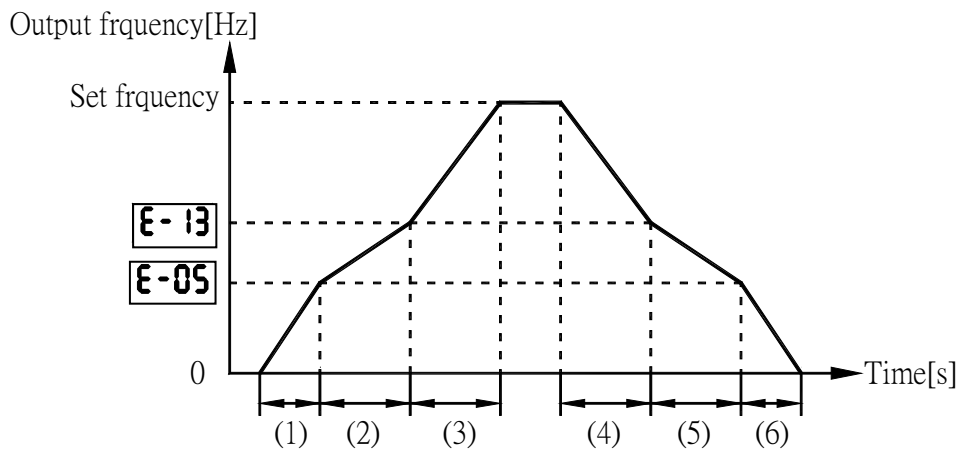

- |  |  |
|--|--|
| 1) Acceleration at the gradient corresponding to acceleration time <b>U-07</b> | 4) Deceleration at the gradient corresponding to deceleration time <b>E-11</b> |
| 2) Acceleration at the gradient corresponding to acceleration time <b>E-00</b> | 5) Deceleration at the gradient corresponding to deceleration time <b>E-01</b> |
| 3) Acceleration at the gradient corresponding to acceleration time <b>E-10</b> | 6) Deceleration at the gradient corresponding to deceleration time <b>U-08</b> |

3) Switching using external terminals - Switching the acceleration / deceleration time via external terminals

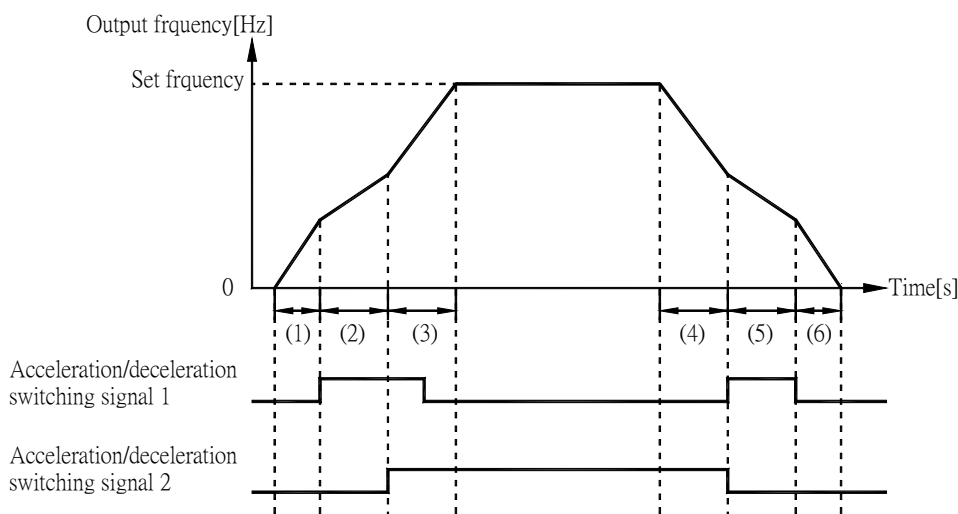

- |  |  |
|--|--|
| 1) Acceleration at the gradient corresponding to acceleration time <b>U-07</b> | 4) Deceleration at the gradient corresponding to deceleration time <b>E-11</b> |
| 2) Acceleration at the gradient corresponding to acceleration time <b>E-00</b> | 5) Deceleration at the gradient corresponding to deceleration time <b>E-01</b> |
| 3) Acceleration at the gradient corresponding to acceleration time <b>E-10</b> | 6) Deceleration at the gradient corresponding to deceleration time <b>U-08</b> |

■ How to set parameters

- a) Operating method: Terminal input

Set the operation control mode selection **U-01** to **0**.

- b) Use the S2 and S3 terminals for switching. (Instead, other terminals may be used.)

S2: Acceleration/deceleration switching signal 1

S3: Acceleration/deceleration switching signal 2

Title	Function	Adjustment range	Default setting
<b>A-15</b>	Input terminal selection 5 (S2)	0-65	5 (the second acceleration/deceleration mode selection)
<b>A-16</b>	Input terminal selection 6 (S3)	0-65	58 (the third acceleration/deceleration mode selection)

■ Acceleration/ deceleration pattern

Acceleration/deceleration patterns can be selected individually, using the acceleration/deceleration 1, 2 and 3 parameters.

- 1) Linear acceleration/deceleration
- 2) S-pattern acceleration/deceleration 1
- 3) S-pattern acceleration/deceleration 2

Title	Function	Adjustment range	Default setting
<b>E-02</b>	Acceleration/ deceleration 1 pattern	0: Linear	0
<b>E-03</b>	Acceleration/ deceleration 2 pattern	1: S-pattern 1	0
<b>E-12</b>	Acceleration/ deceleration 3 pattern	2: S-pattern 2	0

★ For an explanation of acceleration/deceleration patterns, see 7.18.1 (Page 7-57).

★ Both the settings of the S-pattern lower-limit and upper-limit adjustment parameters (**E-06** and **E-07**) are applied to any acceleration/deceleration S-pattern.

## 7.19 Protection functions

### 7.19.1 Setting motor electronic thermal protection

**U-16** :Motor electronic thermal protection level 1  
**A-13** :Motor electronic thermal protection level 2  
**F-01** :Motor 150%-overload time limit

■ Function

This parameter allows selection of the appropriate electronic thermal protection characteristics according to the particular rating and characteristics of the motor

[Parameter setting]



Title	Function	Adjustment range	Default setting
<b>U-16</b>	Motor electronic thermal protection level 1	10-100 (%) / (A)	100
<b>R-73</b>	Motor electronic thermal protection level 2	10-100 (%) / (A)	100
<b>F-01</b>	Motor 150%-overload time limit	10-2400 (s)	300

For more details see 6.13 (Page 6-25)

Note: The 100% standard value is the rated output current indicated on the nameplate.

### 7.19.2 Setting current stall

**F-01** :Stall prevention level 1  
**R-85** :Stall prevention level 2

 Caution	
 Prohibited	<ul style="list-style-type: none"> <li>Do not set the stall prevention level (<b>F-01</b>) extremely low. If the stall prevention level parameter (<b>F-01</b>) is set at or below the no-load current of the motor, the stall preventive function will be always active and increase the frequency when it judges that regenerative braking is taking place.</li> <li>Do not set the stall prevention level parameter (<b>F-01</b>) below 30% under normal use conditions</li> </ul>

■ Function

This parameter adjusts the output frequency by activating a current stall prevention function against a current exceeding the **F-01**-specified level.

[Parameter setting]

Title	Function	Adjustment range	Default setting
<b>F-01</b>	Stall prevention level 1	10-199 (%) / (A), 200: Deactivated	150
<b>R-85</b>	Stall prevention level 2		

[Display during operation of the stall prevention]

During an **OC** alarm status, (that is, when there is a current flow in excess of the stall prevention level), the output frequency changes. At the same time, to the left of this value, “**C**” is displayed flashing on and off.

Example of display



- ★ The switching from **F-01** to **A-85** can be performed by entering a command through terminals. For more details, see 7.4.1(Page 7-16).

Note. The 100% standard value is the rated output current indicated on the nameplate.

### 7.19.3 Inverter trip retention

**F-02 :Inverter trip retention selection**

■ Function

If the inverter trip, this parameter will retain the corresponding trip information. Trip information that has thus been stored into memory can be displayed, even after power has been reset.

[Parameter setting]

Title	Function	Adjustment range	Default setting
<b>F-02</b>	Inverter trip retention selection	0: Cleared if power is turned off 1: Retained even if power is turned off	0

- ★ The causes of up to four trips that occurred in the past can be displayed in status monitor mode.
- ★ Data displayed in status monitor mode when the inverter is tripped is cleared when power is turned off. Past trip records can be displayed.
- ★ Trip records are retained even if power is turned off and turned back on during retry operation.

■ Flow of operation when **F-02 = 1**

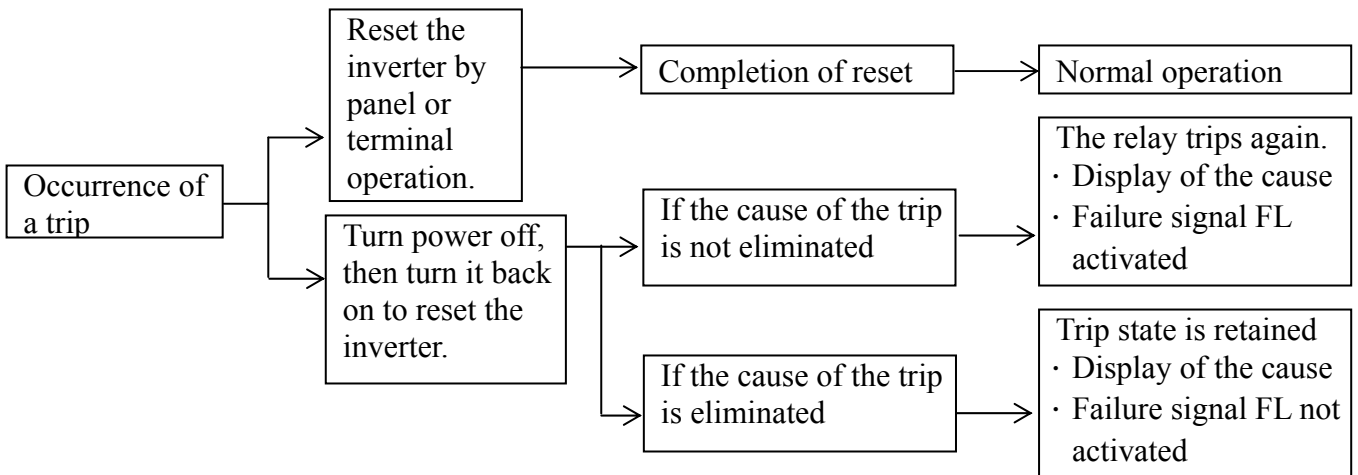

## 7.19.4 Emergency stop

**F-03** :Emergency stop  
**F-04** :Emergency DC braking time  
**b-51** :DC braking current  
**R-13** :Input terminal selection 3 (RES)

### ■ Function

These parameters allow you to specify how to stop operation using an external control device when an external trip occurs. When operation is stopped, the trip **ESTP** and the FL relay also are activated. When setting **F-03** to **2** (emergency DC braking), set also **b-51** (DC braking rate) and **F-04** (emergency braking time)

#### 1) External trip stop via terminals

The external trip stop function can be executed via the a-contact. Proceed as follows to assign an external stopping terminal and select the stopping method:

[Parameter setting]

Title	Function	Adjustment range	Default setting
<b>F-03</b>	Emergency stop selection	0: Coast stop 1: Slowdown stop 2: Emergency DC braking	0
<b>F-04</b>	Emergency DC braking time	0.0 ~ 20.0 [sec]	1.0
<b>b-51</b>	DC braking current	0-100 (%)	50

(Example of terminal assignment): Assigning the trip stop function to the RES terminal

Title	Function	Adjustment range	Default setting
<b>R-13</b>	Input terminal selection 3 (RES)	0-65	11 (External trip stop)

Note 1) Emergency stopping via the specified terminal is possible, even during panel operation.

Note 2) If DC braking is not needed to bring the motor to a stop under normal conditions, although **F-03** is set to 2 (emergency DC braking), set the DC braking starting frequency (**b-50**) at 0.0 Hz.

#### 2) Emergency stopping from the operation panel

Emergency stopping from the operation panel is possible by pressing the STOP key on the panel twice while the inverter is not in the panel control mode.

- (1) Press the STOP key .....” **EOFF** ” will blink.
- (2) Press the STOP key once again.....Operation will come to a trip stop in accordance with the setting of the **F-03** parameter.  
After this, “ **ESLP** ” will be displayed and a failure detection signal generated (FL relay deactivated).

### 7.19.5 Output phase failure detection

#### **F-05 :Output phase failure detection mode selection**

##### ■ Function

This parameter detects inverter output Phase failure. If the Phase failure status persists for one second or more, the tripping function and the FL relay will be activated. At the same time, a trip information **PF-0** will also be displayed.

Set **F-05** to **5** to open the motor-inverter connection by switching commercial power operation to inverter operation.

Detection errors may occur for special motors such as high-speed motors.

**F-05 = 0**: No tripping (FL relay deactivated).

**F-05 = 1**: With the power on, the phase failure detection is enabled only at the start of the first operation. The inverter will trip if the Phase failure status persists for one second or more.

**F-05 = 2**: The inverter checks for output phase failures each time it starts operation. The inverter will trip if the Phase failure status persists for one second or more.

**F-05 = 3**: The inverter checks for output phase failures during operation. The inverter will trip if the Phase failure status persists for one second or more.

**F-05 = 4**: The inverter checks for output phase failures at the start of and during operation. The inverter will trip if the Phase failure status persists for one second or more.

**F-05 = 5**: If it detects an all-phase failure, it will restart on completion of reconnection. The inverter does not check for output phase failures when restarting after a momentary power failure.

Note: A check for output phase failures is made during auto-tuning, regardless of the setting of this parameter.

[Parameter setting]

Title	Function	Adjustment range	Default setting
<b>F-05</b>	Output phase failure detection mode selection	0: Disabled 1: At start-up (Only one time after power is turned on) 2: At start-up (each time) 3: During operation 4: At start-up + during operation 5: Detection of cutoff on output side	0

### 7.19.6 Input phase failure detection

#### **F-08 :Input phase failure detection mode selection**

##### ■ Function

This parameter detects inverter input Phase failure. If the abnormal voltage status of main circuit capacitor persists for few minutes or more, the tripping function and the FL relay will be activated. Therefore, input phase failures cannot always be detected. A trip information **PF-!** will be displayed.

If the power capacity is larger than the inverter capacity (more than 200kVA or more than 10 times), detection errors may occur. If this actually happens, install an AC or DC reactor .

**F-08=0** : No tripping (Failure signal FL not activated)

**F-08=!** : Phase failure detection is enabled during operation. The inverter will trip if the abnormal voltage status of main circuit capacitor persists for ten minutes or more. (Failure signal FL activated)

[Parameter setting]

Title	Function	Adjustment range	Default setting
<b>F-08</b>	Input phase failure detection mode selection	0: Disabled, 1: Enabled	1

Note1: Setting **F-08** to **0** (input phase failure detection: disabled) may result in a breakage of the capacitor in the inverter main circuit if operation is continued under a heavy load in spite of the occurrence of an input phase failure.

Note2: Parameter **F-08** is invalid for single-phase input model.

## 7.19.7 Control mode for small current

**F-10** : Small current trip / alarm selection  
**F-11** : Small current detection current  
**F-12** : Small current detection time

### ■ Function

The **F-10** parameter allows the inverter to be tripped if a current smaller than the **F-11** - specified value flows for more than the **F-12** -specified time. When tripping is selected, enter the detection time to tripping. Trip information is displayed as “**[PF9]**”.

**F-10=0** : No tripping (Failure signal FL not activated).

A small current alarm can be put out by setting the output terminal function selection parameter.

**F-10=1** : The inverter will trip (Failure signal FL activated) if a current below the current set with **F-11** flows for the period of time specified with **F-12** .

Title	Function	Adjustment range	Default setting
<b>F-10</b>	Small current trip/alarm selection	0: Alarm only 1: Tripping	0
<b>F-11</b>	Small current detection current	0-100 (%) / (A)	0
<b>F-12</b>	Small current detection time	0-255 [sec]	0

< Example of operation >

Output terminal function: 24 (UC) Low current detection

**F-10=0** (Alarm only)

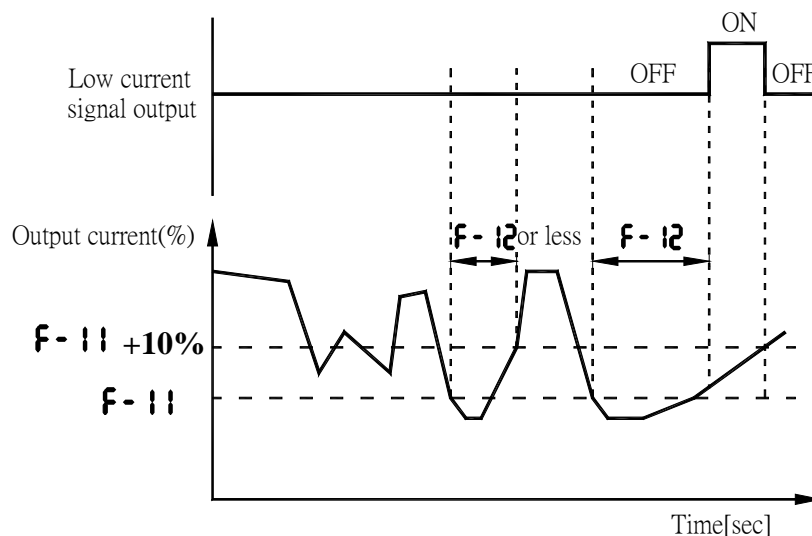

- ※ When setting **F-10** to 1 (Trip), trip after low current detection time setting of **F-12**. After tripping, the low current signal remains ON.

### 7.19.8 Detection of output short-circuit

#### **F-13 :Detection of output short-circuit during start-up**

##### ■ Function

This parameter detects inverter output short-circuit. It can be usually detected in the length of the standard pulse. When operating low-impedance motor such as high-speed motor, however, the short-time pulse should be selected.

- F-13=0**: Detection is executed in the length of the standard pulse every time you start up the inverter.
- F-13=1**: Detection is executed in the length of standard pulse only during the first start-up after putting on the power or after resetting.
- F-13=2**: Detection is executed with the short-time pulse every time you start up the inverter.
- F-13=3**: Detection is executed with the short-time pulse only for the first time after putting power on or after resetting.

Title	Function	Adjustment range	Default setting
<b>F-13</b>	Detection of output short-circuit during start-up	0: Each time (standard pulse) 1: Only one time after power is turned on (standard pulse) 2: Each time (short-time pulse) 3: Only one time after power is turned on (short-time pulse)	0

### 7.19.9 Over-torque trip

- F-15 :Over-torque trip / alarm selection**
- F-16 :Over-torque detection level**
- F-18 :Over-torque detection time**
- F-19 :Over-torque detection level hysteresis**

##### ■ Function

Use the **F-15** parameter to trip the inverter or to output the alarm if a torque current exceeding the **F-16**-specified level flows for more than the **F-18**-specified time. Trip information is displayed as “**OL-1**”.

- F-15=0**: ..... No tripping (FL relay deactivated).

An over-torque alarm can be put out by setting the output terminal function selection parameter.

**F-15 = 1**: ..... The inverter is tripped (FL relay activated) only after a torque current exceeding the **F-16** -specified level has been detected for more than the **F-18** -specified time.

Title	Function	Adjustment range	Default setting
<b>F-15</b>	Over-torque trip/alarm selection	0: Alarm only 1: Tripping	0
<b>F-16</b>	Over-torque detection level	0-250 (%)	150
<b>F-18</b>	Over-torque detection time	0.0-10.0 [sec]	0.5
<b>F-19</b>	Over-torque detection level hysteresis	0-100 (%)	10

<Example of operation>

1) Output terminal function: 12 (OT) Over-torque detection

**F-15 = 0** (Alarm only)

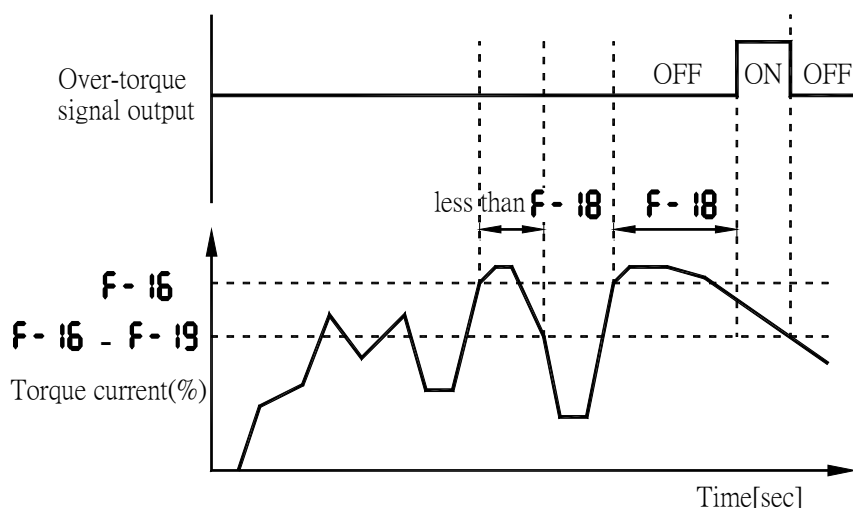

When **F-15 = 1** (tripping), the inverter will trip if over-torque lasts for the period of time set with **F-18**. In such a case, the over-torque signal remains ON.

## 2) Output terminal function: 20 (POT) Over-torque detection pre-alarm

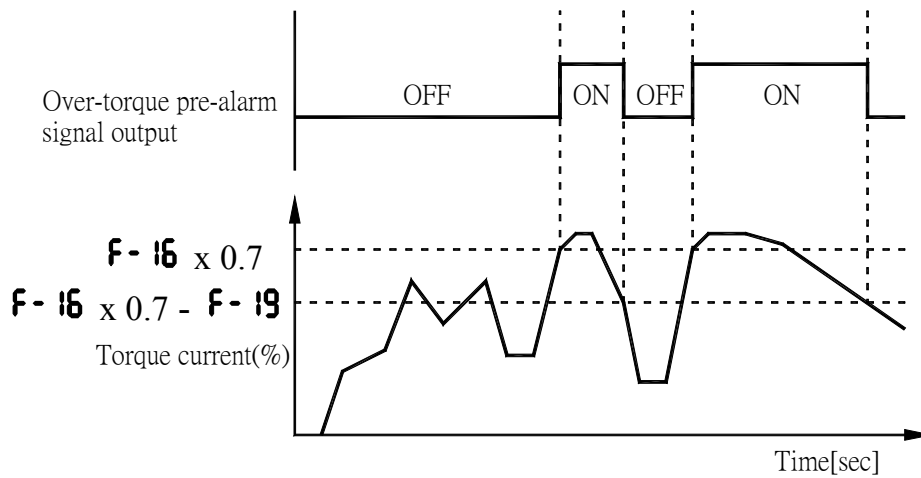

### 7.19.10 Cumulative operation time alarm setting

**F-21 : Cumulative operation time alarm setting**  
**R-31 : Output terminal selection 2A (OUT-NO)**

#### ■ Function

This parameter allows you to set the inverter so that it will put out an alarm signal after a lapse of the cumulative operation time set with **F-21**

- “0.1” displayed on the monitor refers to 10 hours, and therefore “1” denotes 100 hours. Ex.: 38.5 displayed on the monitor = 3850 (hours)

Title	Function	Adjustment range	Default setting
<b>F-21</b>	Cumulative operation time alarm setting	0.0-9.999	610.0

#### ■ Setting of output signal 1

EX: When assigning the cumulative operation alarm signal output function to the OUT terminal

Title	Function	Adjustment range	Default setting
<b>R-31</b>	Output terminal selection 2A (OUT-NO)	0-255	42 (negative logic 43)

### 7.19.11 Over-voltage stall protection level

**F-26 : Over-voltage stall protection level**

\* For more details, see 7.13.5 (Page 7-43).

### 7.19.12 Undervoltage trip

**F-27 :Undervoltage trip / alarm selection**

■ Function

This parameter is used for selecting the control mode when an undervoltage is detected. Trip information is displayed as “**Uu-1**”.

**F-27=0**: The inverter is stopped. However, it is not tripped (Failure signal FL not activated). The inverter is stopped when the voltage does not exceed 60 % or less of its rating.

**F-27=1**: Inverter is stopped. It is also tripped (Failure signal FL activated), only after detection of a voltage not exceeding 60% or less of its rating.

**F-27=2**: Inverter is stopped. However, it is not tripped (Failure signal FL not activated). The inverter stop (Failure signal FL not activated.), only after detection of a voltage not exceeding 50% of its rating.

Title	Function	Adjustment range	Default setting
<b>F-27</b>	Undervoltage trip/alarm selection	0: Alarm only (detection level below 60%) 1: Tripping (detection level below 60%) 2: Alarm only (detection level below 50%, DC reactor needed)	0

### 7.19.13 Trip at VIA low level input mode

**F-33 :Trip at VIA low level input mode**

■ Function

This inverter will trip if the VIA value remains below the specified value for about 0.3 seconds. In such a case, “**RIE1**” is displayed.

**F-33 =0**: Disabled.....The detection function is disabled.

**F-33 =1-100**.....The inverter will trip if the VIA value remains below the specified value for about 0.3 seconds.

Title	Function	Adjustment range	Default setting
<b>F-33</b>	Trip at VIA low level input mode	0: Disabled 1-100%	0

Note : The VIA input value may be judged earlier to be abnormal, depending on the degree of deviation of the analog data detected

## 7.19.14 Parts replacement alarms

### **F-34 :Annual average ambient temperature (Parts replacement alarms)**

#### ■ Function

You can set the inverter so that it will calculate the remaining useful lives of the cooling fan, main circuit capacitor and on-board capacitor from the ON time of the inverter, the operating time of the motor, the output current (load factor) and the setting of **F-34** , and that it will display and send out an alarm through output terminals when each component is approaching the time of replacement.

Title	Function	Adjustment range	Default setting
<b>F-34</b>	Annual average ambient temperature (parts replacement alarms)	1: -10 to +10°C 2: 11-20°C 3: 21-30°C 4: 31-40°C 5: 41-50°C 6: 51-60°C	3

#### ☆ Display of part replacement alarm information

Part replacement alarm information (See page 8-3) in the Status monitor mode allows you to check on the time of replacement.

An example of display: 

#### ☆ Output of part replacement alarm signal

Assign the part replacement alarm function (function No. 44 or 45. See page 5-27) to an output terminal. An example of setting: To assign the function to the RY-RC terminal

**A-30 = 44**

Note 1: Using **F-34** enter the annual average temperature around the inverter. Be careful not to enter the annual highest temperature

Note 2: Set **F-34** at the time of installation of the inverter, and do not change its setting after the start of use. Changing the setting may cause parts replacement alarm calculation error.

## 7.20 Adjustment parameters

### 7.20.1 Pulse train output for meters

**F-69** :Logic output / pulse train output selection (OUT-NO)  
**F-76** :Pulse train output function selection (OUT-NO)  
**F-77** :Maximum numbers of pulse train

■ Function

Pulse trains can be sent out through the OUT-NO output terminals.

To do so, it is necessary to select a pulse output mode and specify the number of pulses.

Ex: When operations frequencies (0 to 60Hz) are put out by means of 0 to 600 pulses

**U-09** =60.0, **F-69**=1, **F-76**=0, **F-77**=600

Title	Function	Adjustment range	Reference of max. value	Default setting
<b>F-69</b>	Logic output/pulse train output selection (OUT-NO)	0: Logic output 1: Pulse train output	—	0
<b>F-76</b>	Pulse train output function selection (OUT-NO)	0: Output frequency 1: Output current 2: Set frequency 3: DC voltage 4: Output voltage command value 5: Input power 6: Output power 7: Torque 8: Torque current 9: Motor cumulative load factor 10: Inverter cumulative load factor 11: PBR (braking reactor) cumulative load factor 12: Frequency setting value (after PID) 13: VIA Input value 14: VIB Input value 15: Fixed output 1 (Output current: 100%) 16: Fixed output 2 (Output current: 50%) 17: Fixed output 3 (Other than the output current: 100%)	<b>U-09</b> 185% <b>U-09</b> 150% 150%  185% 185% 250% 250% 100%  100% 100% <b>U-09</b>  10V/20mA 10V 185% 185% 100%	0
<b>F-77</b>	Maximum numbers of pulse train	500-1600 (pps)	—	800

Note 1: When item of **F-76** reaches “Reference of max. value”, the number of pulse train set by **F-77** are sent to output terminals (OUT-NO)

Note 2: The ON pulse width is maintained constant.

The ON pulse width is fixed at a width that causes the duty to reach 50% at the maximum pulse number set with **F-77**.

Therefore, the duty is variable.

For example, the ON pulse width is approximately 0.6 ms when **F-77=800**, approximately 0.5 ms when **F-77=1000**, or approximately 0.3 ms when **F-77=1600**.

Note 3: The minimum pulse output rate is 38 pps. Keep in mind that no pulses can be put out at any rate smaller than 38 pps.

### 7.20.2 Calibration of analog outputs

**F-91 :Inclination characteristic of analog output**  
**F-92 :Bias of analog output**

#### ■ Function

Output signals from FM terminals are analog voltage signals. Their standard setting range is from 0 to 7.5Vdc.

Using the FM slide switch in the inverter, you can switch to 0-20mA output. Also, using these parameters, you can calibrate the output to 4-20mAdc or 20-4mAdc.

Title	Function	Adjustment range	Default setting
<b>F-91</b>	Inclination characteristic of analog output	0: Negative inclination (downward slope) 1: Positive inclination (upward slope)	1
<b>F-92</b>	Bias of analog output	0-100%	0

Note: To switch to 0-20mAdc (4-20mAdc), turn the FM slide switch to the I position.

■ Example of setting

**F-91=1, F-92=0**

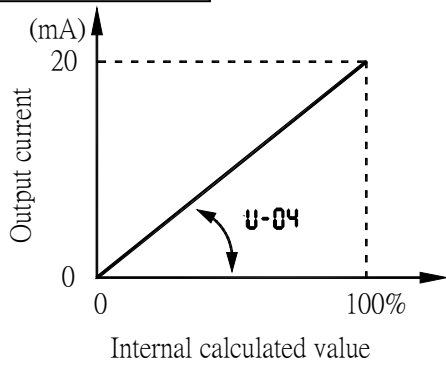

**F-91=1, F-92=20**

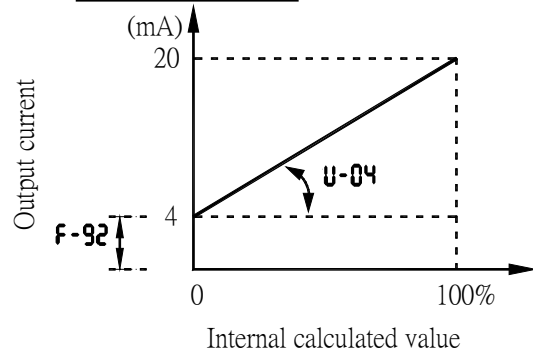

**F-91=0, F-92=100**

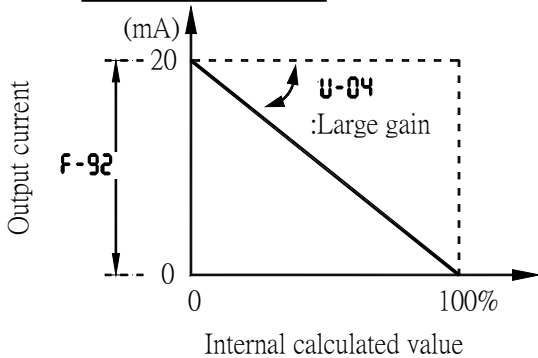

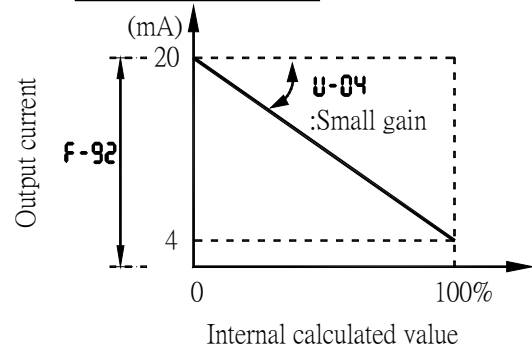

**F-91=0, F-92=100**





☆ The analog output inclination can be adjusted using the parameter **U-04**.

## 7.21 Operation panel parameter



### 7.21.1 Prohibition of key operations and parameter settings

- H-00** :Prohibition of change of parameter setting
- H-30** :Prohibition of panel operation (FC)
- H-33** :Prohibition of panel operation (  /  keys)
- H-34** :Prohibition of panel emergency stop operation
- H-35** :Prohibition of panel reset operation
- H-36** :Prohibition of change of **U-01** / **U-02** during operation

■ Function

These parameters allow you to prohibit the operation of the  and  keys on the operation panel and the change of parameters. Using these parameters, you can also prohibit various key operation.

[Parameter setting]

Title	Function	Adjustment range	Default setting
<b>H-00</b>	Prohibition of change of parameter setting	0: Permitted, 1: Prohibited	0
<b>H-30</b>	Panel operation prohibition (FC)	0: Permitted, 1: Prohibited	0
<b>H-33</b>	Prohibition of panel operation (  /  keys)	0: Permitted, 1: Prohibited	0
<b>H-34</b>	Prohibition of panel emergency stop operation	0: Permitted, 1: Prohibited	0
<b>H-35</b>	Prohibition of panel reset operation	0: Permitted, 1: Prohibited	0
<b>H-36</b>	Prohibition of change of <b>U-01</b> / <b>U-02</b> during operation	0: Permitted, 1: Prohibited	1

■ Resetting method

Only the **H-00** parameter is designed so that its setting can be modified even if 1 (prohibited) is selected.

7.21.2 Changing the display unit to A / V / min<sup>-1</sup>

**H-01 : Current / voltage display mode**

■ Function

These parameters are used to change the unit of monitor display.

%  $\longleftrightarrow$  A (ampere)/V (volt)

■ Example of setting

During the operation of the EI-650-05L (rated current: 17.5A) at the rated load (100% load), units are displayed as follows:

1) Display in percentage terms

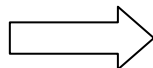
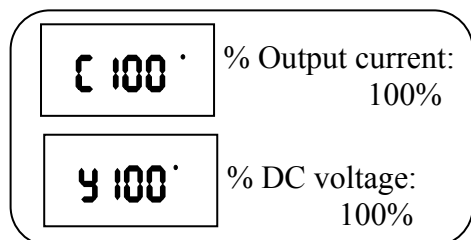

2) Display in amperes / volts

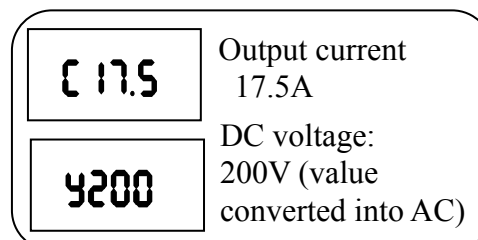



2) Displaying the speed of the loading unit

To switch the display mode from 60Hz (default setting) to 6m/min<sup>-1</sup> (the speed of the conveyer)

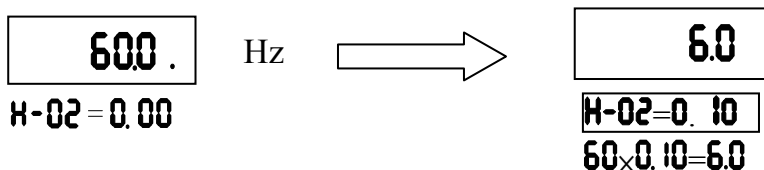

Note: This parameter displays the inverter output frequency as the value obtained by multiplying it by a positive number. This does not mean that the actual motor speed or line speed are indicated with accuracy.

Title	Function	Adjustment range	Default setting
<b>H-02</b>	Frequency free unit magnification	0.00: Free unit display disabled (display of frequency) 0.01-200.0	0.00
<b>H-05</b>	Inclination characteristic of free unit display	0: Negative inclination (downward slope) 1: Positive inclination (upward slope)	1
<b>H-06</b>	Bias of free unit display	0.00 - <b>U-09</b>	0.00

\* The **H-02** to **H-06** converts the following parameter settings:

- Free unit Frequency monitor display      Operation frequency command, Operation frequency, PID feedback, Frequency command value (PID-computed), Operation frequency command at trip

Frequency-related parameters

**U-09, U-10, U-11, U-18, U-24,  
A-00, A-01, A-02, A-67,  
b-02, b-04, b-11,  
b-13, b-40, b-41, b-42,  
b-50, b-60, b-65, b-67,  
b-68, b-70, b-75, b-87, b-94,  
C-43, C-45, E-05, E-13,  
L-12, L-14,**

- An example of setting when **U-09** is 80 and **H-02** is 10.00

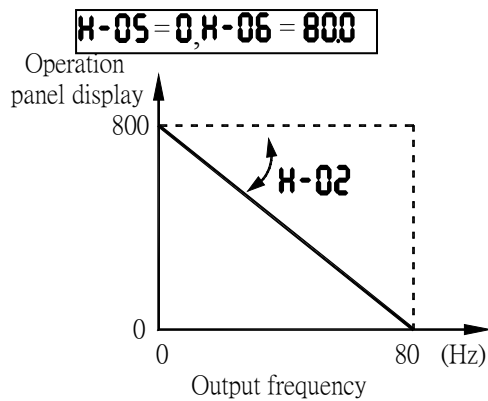
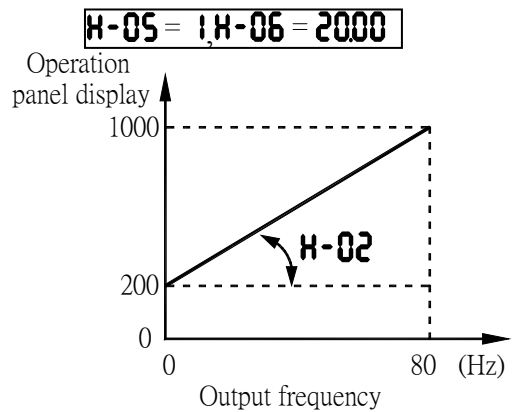
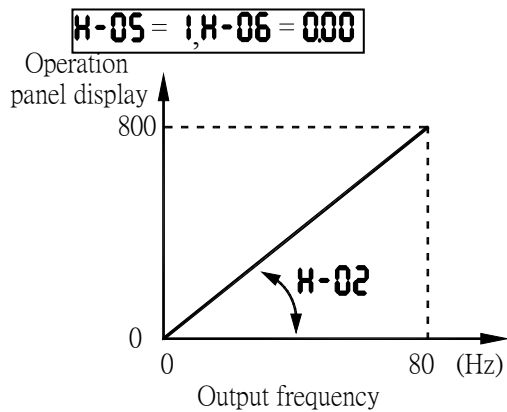

#### 7.21.4 Changing the steps in which the value displayed changes

**H-07** :Free step 1 (pressing a panel key once)  
**H-08** :Free step 2 (panel display)

##### ■ Function



These parameters are used to specify steps in which the command value or standard monitor output frequency displayed on the panel changes each time you press the up or down key to set a frequency on the operation panel.

Note 1: The settings of these parameters have no effect when the free unit selection (**H-02**) is enabled.

Note 2: If you press the Up key on the panel repeatedly to increase the frequency while **H-07** is set to any value other than 0, the “HI” alarm will appear immediately before the frequency exceeds the **U-09** (maximum frequency) and the frequency will stop increasing. Similarly, if you press the Down key on the panel repeatedly to decrease the frequency, the “LO” alarm will appear immediately before the

frequency decreases below the **U-11** (lower-limit frequency) and the frequency will stop decreasing.

- When **H-07** is not 0.00, and **H-08** is not 0 (disabled)

Under normal conditions, the frequency command value from the operation panel increases in steps of 0.1Hz each time you press the  key. If **H-07** is not 0.00, the frequency command value will increase by the value with **H-07** each time you press the  key. Similarly, it will decrease by the value set with **H-07** each time you press the  key.

In this case, the output frequency displayed in standard monitor mode changes in steps of 0.1 Hz, as usual.

- When **H-07** is not 0.00, and **H-08** is not 0 (disabled)

The value displayed on the panel also can also be changed in steps.

$$\boxed{\text{Output frequency displayed in standard monitor mode}} = \boxed{\text{Internal output frequency}} \times \frac{\mathbf{H-08}}{\mathbf{H-07}}$$

Title	Function	Adjustment range	Default setting
<b>H-07</b>	Free step 1 (pressing a panel key once)	0.00: Disabled 0.01 - <b>U-09</b> (Hz)	0.00
<b>H-08</b>	Free step 2 (panel display)	0: Disabled 1-255	0

- Example of setting 1

When **H-07** = 10.00 (Hz):

The frequency (**Ff**) set on the operation panel changes in steps of 10.0 Hz: 0.0 → 20.0 → ... 60.0 (Hz), each time you press the  key. This function comes in very handy when operating the load at limited frequencies that change in steps of 1Hz, 5Hz, 10Hz, and so on.

- Example of setting 2

When **H-07** = 1.00 (Hz), and **H-08** = 1:

Each time you press the  key, the frequency setting **Ff** changes in steps of 1Hz: 0 → 1 → 2 → ... → 60 (Hz) and also the value displayed on the operation panel changes in steps of 1. Use these settings to hide decimal fractions and also the value displayed on the operation panel changes in steps of 1. Use these settings to hide decimal fractions.

## 7.21.5 Changing the item displayed by default

### H-10 :Standard monitor display selection

#### ■ Function

This parameter specifies display format while power is on.

#### ■ Changing the display format while power is on

When the power is on, the standard monitor mode displays the operation frequency (default setting) in the format of “00” or “OFF”. This format can be changed to any other monitor display format by setting H-10. This new format, however, will not display an assigned prefix such as  $\text{t}$  or  $\text{C}$ .

#### ■ Parameter setting

Title	Function	Adjustment range	Default setting
H-10	Standard monitor display selection	0: Operation frequency (Hz/free unit/step) 1: Frequency command (Hz/free unit/step) 2: Output current (%/A) 3: Inverter rated current (A) 4: Inverter load factor (%) 5: Output power (kW) 6: Frequency command after PID control (Hz/free unit/step) 7: Optional item specified from an external control unit	0

☆ For more information on the H-10 option “7” refer to “Communications Function Instruction Manual”.

## 7.21.6 Canceling the operation command

### H-19 :Canceling of operation command when standby terminal (ST) is turned off

#### ■ Function

When the standby (ST) terminal is turned off during panel operation, the inverter will restart operation if the ST terminal is turned back on. Using this parameter, you can also set the inverter so that, even if the ST is turned back on, it will not restart operation until you press the  key.



■ Parameter setting

Title	Function	Adjustment range	Default setting
<b>H-19</b>	Canceling of operation command when standby terminal (ST) is turned off	0: Operation command canceled (cleared) 1: Operation command retained	1

### 7.21.7 Selection of operation panel stop pattern

#### **H-21 : Selection of operation panel stop pattern**

■ Function

This parameter are used to select a mode in which the motor started by pressing the  key on the operation panel is stopped when the  key is pressed.

1) Slowdown stop

The motor slows down to a stop in the deceleration time set with **U-08** (or **E-01** or **E-11** ).

2) Coast stop

The inverter cuts off power supply to the motor. The motor comes to a stop after coasting for a while by inertia. Depending on the load, the motor may keep running for a good long time.

.[Parameter setting]

Title	Function	Adjustment range	Default setting
<b>H-21</b>	Selection of operation panel stop pattern	0: Slowdown stop 1: Coast stop	0

## 7.22 Communication function (Common serial)

### 7.22.1 Setting of common function

L-00	:Communication rate
L-01	:Parity
L-02	:Inverter number
L-03	:Communication error trip time
L-05	:Communication waiting time
L-06	:Setting of master and slave for communication between inverters
L-11	:Communication command point 1 setting
L-12	:Communication command point 1 frequency
L-13	:Communication command point 2 setting
L-14	:Communication command point 2 frequency
L-29	:Selection of communication protocol
L-70	:Block write data 1
L-71	:Block write data 2
L-75	:Block read data 1
L-76	:Block read data 2
L-77	:Block read data 3
L-78	:Block read data 4
L-79	:Block read data 5
L-80	:Free notes

#### ■ Function

Function The EI-650 Series allows a data communication network to be constructed for exchanging data between a host computer or controller (referred to collectively as the computer) and the inverter by connecting S+ and S- RS485 communication terminal.

<Computer-linking functions>

The following functions are enabled by data communication between the computer and inverter

- (1) Monitoring inverter status (such as the output frequency, current, and voltage)
- (2) Sending RUN, STOP and other control commands to the inverter
- (3) Reading, editing and writing inverter parameter settings

<RS485 communication>

Data can be exchanged between the computer and each of the inverters connected.

#### ■ Communication function parameters (Common serial options)

The data transfer speed, parity type, inverter number, and communication error trip time can be set/edited by operation panel operation or communication function.

Title	Function	Adjustment range	Default setting
L-00	Communication rate	0: 1200bps 1: 2400bps 2: 4800bps 3: 9600bps 4: 19200bps	3
L-01	Parity	0: NON (No parity) 1: EVEN (Even parity) 2: ODD (Odd parity)	1
L-02	Inverter number	0-255	0
L-03	Communication error trip time	0: Disabled (*) 1-100 (s)	0
L-05	Communication waiting time	0.00: Regular communication 0.01-2.00 (s)	0.00
L-06	Setting of master and slave for communication between inverters	0: Slave (0 Hz command issued in case the master inverter fails) 1: Slave (Operation continued in case the master inverter fails) 2: Slave (Emergency stop tripping in case the master inverter fails) 3: Master (transmission of frequency commands) 4: Master (transmission of output frequency signals)	0
L-11	Communication command point 1 setting	0-100 (%)	0
L-12	Communication command point 1 frequency	0-500.0 (Hz)	0.0
L-13	Communication command point 2 setting	0-100 (%)	100
L-14	Communication command point 2 frequency	0-500.0 (Hz)	50.0
L-29	Selection of communication protocol	0: Reserve 1: ModbusRTU protocol	1

Title	Function	Adjustment range	Default setting
L-70	Block write data 1	0: No selection 1: Command 1 2: Command 2 3: Frequency command	0
L-71	Block write data 2	4: Output data on the terminal board 5: Analog output for communications	0
L-75	Block read data 1	0: No selection 1: Status information	0
L-76	Block read data 2	2: Output frequency 3: Output current	0
L-77	Block read data 3	4: Output voltage 5: Alarm information	0
L-78	Block read data 4	6: PID feedback value 7: Input terminal board monitor 8: Output terminal board monitor	0
L-79	Block read data 5	9: VIA terminal board monitor 10: VIB terminal board monitor	0
L-80	Free notes	0-65535	0

★ Disabled..... Indicates that the inverter will not be tripped even if a communication error occurs.

Trip ..... The inverter trips when a communication time-over occurs.  
In this case a trip information **LE-1** flashes on and off on the operation panel.

### 7.22.2 Using the RS485

#### ■ Setting the communication functions

Setting commands and frequencies by communications has priority over sending commands from the operation panel or the terminal board. Command/frequency setting by communications can therefore be enabled, irrespective of the setting in the command mode (**U-01**) or the frequency setting mode (**U-02**). When inverters are connected to each others, however, in order for slave inverters to recognize frequency signals from the master inverter as frequency commands, the frequency setting mode selection 1 parameter (**U-02**) provided for each slave inverter needs to be set to 4 (serial communications). Refer to the COMMUNICATIONS EQUIPMENT USER'S MANUAL for details. However, when the input terminal function selection parameter is set to 48: SC/LC (Page 5-24)(Serial/Local selection), the inverter can be operated with the settings of the command mode (**U-01**) or the frequency setting mode (**U-02**)

by external input.

■ Transmission specifications

Item	Specifications
Transmission scheme	Half-duplex
Connection scheme	Centralized control
Synchronization scheme	Asynchronous
Transmission rate	Default: 9600 baud (parameter setting) Option: Either 1200, 2400, 4800, 9600, or 19200baud
Character transmission	ASCII code: JIS X 0201 8, 8-bit (fixed) Binary code: Binary, 8-bit (fixed)
Stop bit length	Inverter receiving: 1 bit, Inverter sending: 2 bits
Error detection	Parity: Even, Odd, or None selectable by parameter setting; check sum method
Character transmission format	Receiving: 11-bit, Sending: 12-bit
Order of bit transmission	Least significant bit first
Frame length	Variable to a maximum of 17 bytes

■ Example of connection for RS485-Communication

< Example of connection >

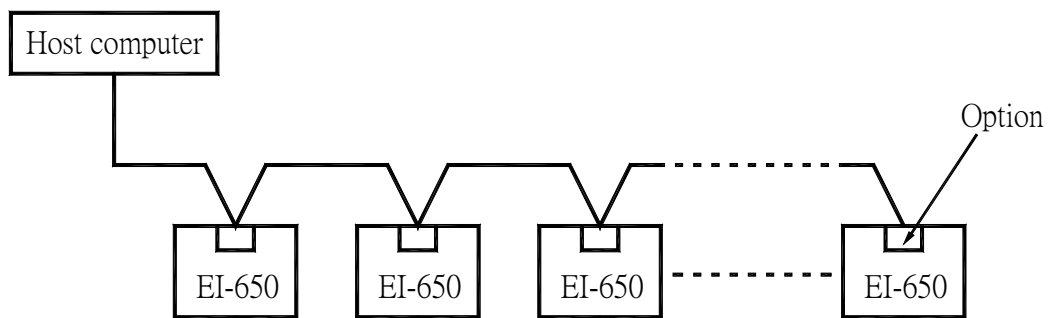

<Independent communication >

Perform computer-inverter connection as follows to send operation frequency commands from the host computer to inverter No. 3:

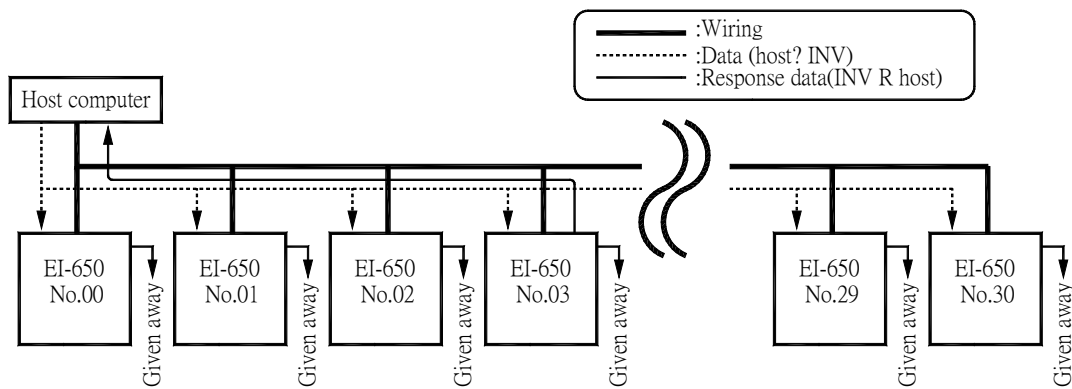

"Given away": Only the inverter with the selected inverter number conducts data processing. All other inverters, even if they have received the data, give it away and stand by to receive the next data.

\* : Use the terminal board to branch the cable.

- (1) Data is sent from the host computer.
- (2) Data from the computer is received at each inverter and the inverter numbers are checked.
- (3) The command is decoded and processed only by the inverter with the selected inverter number.
- (4) The selected inverter responds by sending the processing results, together with its own inverter number, to the host computer.
- (5) As a result, only the selected inverter starts operating in accordance with the operation frequency command by communicating independently.

☆ For details of the communication function, refer to the separate instruction manual, "EI-650 Serial Communication Function".

Note 1.: Limit the distance between the common serial optional units and the inverter to 5m.

## 7.23 Parameters for options

**L-90** :Parameter for option 1  
**L-91** :Parameter for option 2  
**L-92** :Parameter for option 3  
**L-93** :Parameter for option 4  
**L-94** :Parameter for option 5

These parameters can be used only when specific optional parts are installed. Do not use these parameters unless such parts are installed.

## 7.24 Parameters magnetic motors

**P-10** :Step-out detection current level  
**P-11** :Step-out detection time

### ■ Function

If the permanent magnet motor (PM motor) steps out and if the exciting current increases (it increases in such a case) and remains above the value set with **P-10** for the period of time set with **P-11**, the inverter will judge the motor to be stepping out and trip it. At that time, the trip message “**POE1**” is displayed.

Title	Function	Adjustment range	Default setting
<b>P-10</b>	Step-out detection current level	10 ~ 150 (%) / (A)	100
<b>P-11</b>	Step-out detection time	0.0 ~ 25.0 [sec]	1.0

Note 1: When using an PM motor, consult your Rich dealer, since the inverter is not compatible with all types of PM motors.

Note 2: The inverter may fail to detect step-out in some cases, because it uses an electrical method to detect step-out. To avoid detection failures, you are recommended to install a mechanical step-out detector.

## 8. Monitoring the operation status

Refer to 4.1 about flow of monitor.

### 8.1 Status monitor mode













#### 8.1.1 Status monitor under normal conditions

In this mode, you can monitor the operation status of the inverter.

To display the operation status during normal operation:













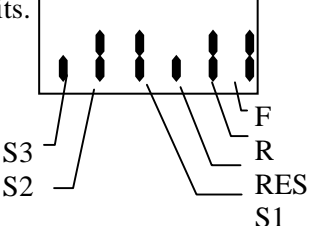



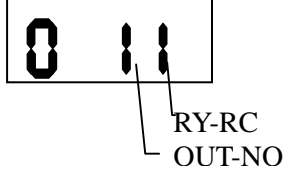















Press the  key twice.

letting procedure (eg. operation at 60Hz)

Item displayed	Key operated	LED display	Communication No.	Description
		<b>600</b>		The operation frequency is displayed (Operation at 60Hz). (When standard monitor display selection <b>H-10</b> is set at 0 [operation frequency])
Parameter setting mode		<b>CU-H</b>		The first basic parameter “ <b>CU-H</b> ” (history function) is displayed.
Direction of rotation		<b>F<sub>r</sub>-F</b>	FE01	The direction of rotation is displayed. ( <b>F<sub>r</sub>-F</b> : forward run, <b>F<sub>r</sub>-r</b> : reverse run)
Note 1 Operation frequency command		<b>F600</b>	FE02	The operation frequency command value (Hz/free unit) is displayed.
Note 2 Load current		<b>C 80</b>	FE03	The inverter output current (load current) (%/A) is displayed.
Note 3 Input voltage		<b>Y 100</b>	FE04	The inverter input (DC) voltage (%/V) is displayed
Output voltage		<b>P 100</b>	FE05	The inverter output voltage (%/V) is displayed.
Torque		<b>9 60</b>	EF18	The torque (%) is displayed.
Torque current		<b>c 90</b>	FE20	The torque current (%/A) is displayed.
Inverter load factor		<b>L 70</b>	FE27	The inverter load factor (%) is displayed.
PBR cumulative load factor		<b>r 50</b>	FE25	The cumulative load factor of the braking resistor (%) is displayed.
Input power		<b>h 80</b>	FE29	The inverter input power (kW) is displayed.
Output power		<b>H 75</b>	FE30	The inverter output power (kW) is displayed.
Operation frequency		<b>o600</b>	FD00	The operation frequency (Hz/free unit) is displayed.

(Continued overleaf)

(Continued)

	Item displayed	Key operated	LED display	Communication No.	Description
Note 4	Input terminal			FE06	<p>The ON/OFF status of each of the control signal input terminals (F, R, RES, S1, S2, S3, VIB and VIA) is displayed in bits.</p>  <p>ON:  OFF: </p>
Note 5	Output terminal			FE07	<p>The ON/OFF status of each of the control signal output terminals (RY, OUT and FL) is displayed in bits.</p>  <p>ON:  OFF: </p>
	CPU1 version			FE08	The version of the CPU1 is displayed.
	CPU2 version			FE73	The version of the CPU2 is displayed.
	Memory version			FE09	The version of the memory mounted is displayed.
	PID feedback			FE22	The PID feedback value is displayed. (Hz/free unit)
	Frequency command value (PID-computed)	  		FE15	The PID-computed frequency command value is displayed. (Hz/free unit)
Note 6	Integral input power			FE76	The integrated amount of power (kWh) supplied to the inverter is displayed. (0.01=1kWh, 1.00=100kWh)
Note 6	Integral output power			FE77	The integrated amount of power (kWh) supplied from the inverter is displayed. (0.01=1kWh, 1.00=100kWh)
	Rated current			FE70	The rated current of the inverter (A) is displayed.
Note 7	Past trip 1			FE10	Past trip 1 (displayed alternately)
Note 7	Past trip 2			FE11	Past trip 2 (displayed alternately)
Note 7	Past trip 3			FE12	Past trip 3 (displayed alternately)

(Continued overleaf)













(Continued)

	Item displayed	Key operated	LED display	Communication No.	Description
Note 7	Past trip 4		nErr ⇄ 4	FE13	Past trip 4 (displayed alternately)
Note 8	Parts replacement alarm information		n ... 1	FE79	<p>The ON/OFF status of each of the cooling fan, circuit board capacitor, main circuit capacitor of parts replacement alarm or cumulative operation time are displayed in bits.</p> <p>ON:   OFF: •</p> <p>Cumulative Operation time</p> <p>Cooling fan</p> <p>Control circuit board capacitor</p> <p>Main circuit capacitor</p>
Note 9	Cumulative operation time		t0.10	FE14	The cumulative operation time is displayed. (0.01=1 hour, 1.00=100 hours)
	Default display mode		600		The operation frequency is displayed (Operation at 60 Hz).

## 8.1.2 Display of detailed information on a past trip

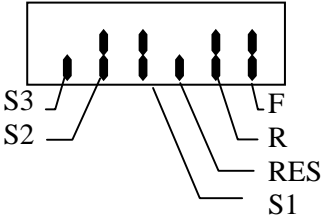
Details on a past trip ( of trips 1 to 4) can be displayed, as shown in the table below, by pressing the  key when the trip record is selected in the status monitor mode.

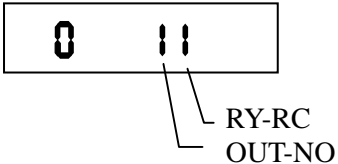
Unlike the “ Display of detailed trip information at the occurrence of a trip” in 8.2.2, details on a past trip can be displayed, even after the inverter is turned off or reset.

	Item displayed	Key operated	LED display	Description
Note 11	Past trip 1		OC - 1 ⇌ 1	Past trip 1 (displayed alternately)
	Continuous trips		n 2	The number of time the same trip occurred in succession is displayed.(Unit: times)
Note 1	Operation frequency		o600	The operation frequency when the trip occurred is displayed.
	Direction of rotation		F <sub>r</sub> -F	The direction of rotation when the trip occurred is displayed. ( F <sub>r</sub> -F: forward run, F <sub>r</sub> -r : reverse run)
	Operation frequency command		F800	The operation command value when the trip occurred is displayed.
Note 2	Load current		C 150	The inverter output current when the trip occurred is displayed.(%/A)
Note 3	Input voltage		y 120	The inverter input voltage (DC) when the trip occurred is displayed. (%/V)
	Output voltage		P 100	The inverter output voltage when the trip occurred is displayed.(%/V)
Note 4	Input terminal		. . . . .	The ON/OFF statuses of the control signal input terminals (F, R, RES, S1, S2, S3, VIB and VIA) is displayed in bits. ON:   OFF: ' 
Note 5	Output terminal		0	The ON/OFF statuses of the control output terminals (RY, OUT and FL) is displayed in bits. ON:   OFF: ' 
Note 9	Cumulative operation time		t856	The cumulative operation time when the trip occurred is displayed. (0.01=1 hour, 1.00=100 hours)
	Past trip 1		OC - 1 ⇌ 1	Press this key to return to past trip 1.

## 8.2 Display of trip information

### 8.2.1 Trip code display

If the inverter trips, an error code is displayed to suggest the cause. Since trip records are retained, information on each trip can be displayed anytime in the status monitor mode.

#### ■ Display of trip information

Error code	Failure code	Description
nErr (*)	0000	No error
OC-1	0001	Overcurrent during acceleration
OC-2	0002	Overcurrent during deceleration
OC-3	0003	Overcurrent during constant speed operation
OC-L	0004	Load-side overcurrent during start-up
OC-R	0005	Armature-side overcurrent during start-up
PF-1	0008	Input phase failure or exhaustion of main circuit capacitor
PF-0	0009	Output phase failure
Ov-1	000A	Overvoltage during acceleration
Ov-2	000B	Overvoltage during deceleration
Ov-3	000C	Overvoltage during constant-speed operation
OL-1	000D	Inverter overload trip
OL-2	000E	Motor overload trip
OL-r	000F	Dynamic braking register overload trip
OH-1	0010	Overheating trip or thermal detector failure
ES&P	0011	Emergency stop
CPF5	0012	E <sup>2</sup> PROM fault 1 (writing error)
CPF6	0013	E <sup>2</sup> PROM fault 2 (initialization error) or power-off during the setting of <b>U-05</b>
CPF7	0014	E <sup>2</sup> PROM fault 3 (reading error)
CPF3	0015	Inverter RAM fault
CPF4	0016	Inverter ROM fault
CPF0	0017	CPU fault trip 1
CE-1	0018	Communication error
CPF8	001A	Current defector fault
OPE1	001B	Optional circuit board format error
CPF9	001D	Small-current trip
Uv-1	001E	Undervoltage trip
Ot-1	0020	Over-torque trip
GF-1	0022	Ground fault

(Continued)

Error code	Failure code	Description
<b>OCP1</b>	0025	Overcurrent flowing in element during acceleration
<b>OCP2</b>	0026	Overcurrent flowing in element during deceleration
<b>OCP3</b>	0027	Overcurrent flowing in element during constant-speed operation
<b>AutE1</b>	0054	Auto-tuning error
<b>OPE2</b>	0029	Inverter type error
<b>OH-2</b>	002E	External thermal input
<b>RIE1</b>	0032	VIA cable break
<b>CE-2</b>	0033	Communication error between CPUs
<b>OPE3</b>	0034	V/F control error
<b>CPF2</b>	0035	CPU fault 2
<b>PNE1</b>	002F	Sep-out (for PM motors only)

(Note) Past trip records (trip records retained or trips that occurred in the past) can be called up.



(Refer to 8.1 “Status monitor mode” for the call-up procedure. )

(\*) Strictly speaking, this code is not an error code; this code is displayed to show the absence of error when the past trip monitor mode is selected.

## 8.2.2 Display of trip information at the occurrence of a trip



















At the occurrence of a trip, the same information as that displayed in the mode described in 8.1.1, “Status monitor under normal conditions” can be displayed, as shown in the table below, if the inverter is not turned off or reset. To display trip information after turning off or resetting the inverter, follow the steps described in 8.1.2, “Display of detailed information on a past trip.”

### ■ Example of call-up of trip information

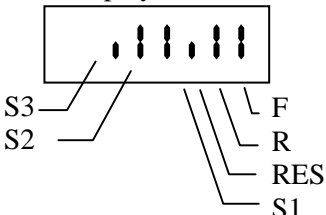
Item displayed	Key operated	LED display	Communication No.	Description
Cause of trip		<b>OU-2</b>		Status monitor mode (The code blinks if a trip occurs.) The motor coasts and comes to a stop (coast stop).
Parameter setting mode		<b>OU-H</b>		The first basic parameter “ <b>OU-H</b> ” (history function) is displayed.
Direction of rotation		<b>FR-F</b>	FE01	The direction of rotation is displayed. ( <b>FR-F</b> : forward run, <b>FR-r</b> : reverse run)

(Continued overleaf)

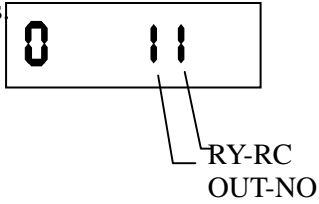
(Continued)

	Item displayed	Key operated	LED display	Communication No.	Description
Note 1	Operation frequency command		<b>F600</b>	FE02	The operation frequency command value (Hz/free unit) at the occurrence of a trip is displayed..
Note 2	Load current		<b>C 130</b>	FE03	The output power of the inverter at the occurrence of a trip (%/A) is displayed.
Note 3	Input voltage		<b>Y 141</b>	FE04	The inverter input (DC) voltage (%/V) at the occurrence of a trip is displayed
	Output voltage		<b>P 100</b>	FE05	The output voltage of the inverter at the occurrence of a trip (%/V) is displayed.
	Torque		<b>q 60</b>	EF18	The torque at the occurrence of a trip (%) is displayed.
	Torque current		<b>c 90</b>	FE20	The torque current (%/A) at the occurrence of a trip is displayed.
	Inverter load factor		<b>L 70</b>	FE27	The inverter load factor (%) at the occurrence of a trip is displayed.
	PBR cumulative load factor		<b>r 50</b>	FE25	The cumulative load factor (%) of the resistor at the occurrence of a trip is displayed.
	Input power		<b>h 80</b>	FE29	The inverter input power (kW) at the occurrence of a trip is displayed.
	Output power		<b>H 75</b>	FE30	The inverter output power (kW) at the occurrence of a trip is displayed.
	Operation frequency		<b>o600</b>	FE00	The inverter output frequency (Hz/free unit) at the occurrence of a trip is displayed.
Note 4	Input terminal		<b>•••••</b>	FE06	The ON/OFF statuses of the control input terminals (F, R, RES, S1, S2, S3, VIB and VIA) are displayed in bits. ON:  FF:  
Note 5	Output terminal		<b>0 11</b>	FE07	The ON/OFF status of each of the control signal output terminals (RY, OUT and FL) at the occurrence of a trip is displayed in bits. ON:  OFF:  
	CPU1 version		<b>u650</b>	FE08	The version of the CPU1 is displayed.
	CPU2 version		<b>uc65</b>	FE73	The version of the CPU2 is displayed.

(Continued overleaf)

(Continued)

	Item displayed	Key operated	LED display	Communication No.	Description
	Memory version		uE00	FE09	The version of the memory mounted is displayed.
	PID feedback		d 50	FE22	The PID feedback value at the occurrence of a trip is displayed. (Hz/free unit)
	Frequency command value (PID-computed)		b 70	FE15	The PID-computed frequency command value at the occurrence of a trip is displayed. (Hz/free unit)
	Integral input power		h 85	FE76	The integrated amount of power (kWh) supplied to the inverter is displayed. (0.01=1kWh, 1.00=100kWh)
	Integral output power		H 75	FE77	The integrated amount of power (kWh) supplied from the inverter is displayed. (0.01=1kWh, 1.00=100kWh)
	Rated current		A 165	FE70	The inverter rated current (A) at the occurrence of a trip is displayed.
Note 7	Past trip 1		Uu-2⇔1	FE10	Past trip 1 (displayed alternately)
Note 7	Past trip 2		OH-1⇔2	FE11	Past trip 2 (displayed alternately)
Note 7	Past trip 3		OU-3⇔3	FE12	Past trip 3 (displayed alternately)
Note 7	Past trip 4		nErr⇔4	FE13	Past trip 4 (displayed alternately)
Note 8	Parts replacement alarm information		n . . .	FE79	<p>The ON/OFF status of each of the cooling fan, circuit board capacitor, main circuit capacitor of parts replacement alarm or cumulative operation time are displayed in bits.</p> <p>ON:   OFF: •</p> <p>Cumulative Operation time</p> <p>Cooling fan</p> <p>Control circuit board capacitor</p> <p>Main circuit capacitor</p>
Note 9	Cumulative operation time		t0.10	FE14	The cumulative operation time is displayed. (0.01=1 hour, 1.00=100 hours)
	Default display mode		OU-2		The cause of the trip is displayed



Note 11: If there is no trip record, **nErr** is displayed.

☆ Of the item displayed on the monitor, the reference values of items expressed in percent are listed below.

- Load current: The current monitored is displayed. The reference value (100% value) is the rated output current indicated on the nameplate. That is, it corresponds to the rated current at the time when PWM carrier frequency (**C-00**) is 4kHz or less. The unit can be switched to A (amperes).
- Input voltage: The voltage displayed is the voltage determined by converting the voltage measured in the DC section into an AC voltage. The reference value (100% value) is 200 volts for 240V models, 400 volts for 500V models or 575 volts for 600V models. The unit can be switched to V (volts).
- Torque: The torque generated by the drive motor is displayed. The reference value (100% value) is the rated torque of the motor.
- Torque current: The current required to generate torque is calculated from the load current by vector operations. The value thus calculated is displayed. The reference value (100% value) is the value at the time when the load current is 100%.
- Load factor of inverter: Depending on the PWM carrier frequency (**C-00**) setting and so on, the actual rated current may become smaller than the rated output current indicated on the nameplate. With the actual rated current at that time (after a reduction) as 100%, the proportion of the load current to the rated current is indicated in percent. The load factor is also used to calculate the conditions for overload trip (**OL - 1**).

- PBR cumulative load factor: The load factor of the braking resistor that may come up to the level at which an overload trip (OL-r) occurs is indicated in percent. An overload trip occurs when it reaches 100%.

## 9. Before making a service call

### - Trip information and remedies

#### 9.1 Trip causes / warnings and remedies

When a problem arises, diagnose it in accordance with the following table.  
If it is found that replacement of parts is required or the problem cannot be solved by any remedy described in the table, contact your Rich dealer.

[Trip information]

Error code	Failure code	Problem	Possible causes	Remedies
OC-1 OCP1	0001 0025	Overcurrent during acceleration Overcurrent flowing in element during acceleration	<ul style="list-style-type: none"> <li>The acceleration time <b>U-07</b> is too short.</li> <li>The V/F setting is improper.</li> <li>A restart signal is input to the rotating motor after a momentary stop, etc.</li> <li>A special motor (e.g. motor with a small impedance) is used.</li> </ul>	<ul style="list-style-type: none"> <li>Increase the acceleration time <b>U-07</b>.</li> <li>Check the V/F parameter.</li> <li>Use <b>C-01</b> (auto-restart) and (ride-through control).</li> <li>Adjust the carrier frequency <b>C-00</b>.</li> <li>Set the carrier frequency control mode selection parameter <b>C-16</b> to 1 or 3 (carrier frequency decreased automatically).</li> </ul>
OC-2 OCP2	0002 0026	Overcurrent during deceleration Overcurrent flowing in element during deceleration	<ul style="list-style-type: none"> <li>The deceleration time <b>U-08</b> is too short.</li> </ul>	<ul style="list-style-type: none"> <li>Increase the deceleration time <b>U-08</b>.</li> <li>Set the carrier frequency control mode selection parameter <b>C-16</b> to 1 or 3 (carrier frequency decreased automatically).</li> </ul>
OC-3 OCP3	0003 0027	Overcurrent during constant speed operation Overcurrent flowing in element during operation	<ul style="list-style-type: none"> <li>The load fluctuates abruptly.</li> <li>The load is in an abnormal condition.</li> </ul>	<ul style="list-style-type: none"> <li>Reduce the load fluctuation.</li> <li>Check the load (operated machine).</li> <li>Set the carrier frequency control mode selection parameter <b>C-16</b> to 1 or 3 (carrier frequency decreased automatically).</li> </ul>
OCP1 OCP2 OCP3	0025 0026 0027	Ground fault trip Arm overcurrent at start-up (for 11 and 15 kW models only)	<ul style="list-style-type: none"> <li>A current leaked from an output cable or the motor to ground.</li> <li>A main circuit element is defective.</li> </ul>	<ul style="list-style-type: none"> <li>Check cables, connectors, and so on for ground faults.</li> <li>Make a service call.</li> </ul>

\* You can select a trip ON/OFF by parameters.

(Continued overleaf)

(Continued )

<b>OC-L</b>	0004	Overcurrent (An overcurrent on the load side at start-up)	<ul style="list-style-type: none"> <li>• The insulation of the output main circuit or motor is defective.</li> <li>• The motor has too small impedance.</li> <li>• A 11 or 15 kW model was started, although a current is leaked from an output cable or the motor to ground.</li> </ul>	<ul style="list-style-type: none"> <li>• Check the cables and wires for defective insulation.</li> <li>• When using a 11 or 15 kW model, check cables, connectors, and so on for ground faults.</li> </ul>
<b>OC-R</b>	0005	Arm overcurrent at start-up	<ul style="list-style-type: none"> <li>• A main circuit elements is defective.</li> </ul>	<ul style="list-style-type: none"> <li>• Make a service call.</li> </ul>
* <b>PF-I</b>	0008	Input phase failure	<ul style="list-style-type: none"> <li>• A phase failure occurred in the input line of the main circuit.</li> <li>• The capacitor in the main circuit lacks capacitance.</li> </ul>	<ul style="list-style-type: none"> <li>• Check the main circuit input line for phase failure.</li> <li>• Enable <b>F-08</b> (input phase failure detection).</li> <li>• Check the capacitor in the main circuit for exhaustion.</li> </ul>
* <b>PF-O</b>	0009	Output phase failure	<ul style="list-style-type: none"> <li>• A phase failure occurred in the output line of the main circuit.</li> </ul>	<ul style="list-style-type: none"> <li>• Check the main circuit output line, motor, etc. for phase failure.</li> <li>• Enable <b>F-05</b> (Output phase failure detection).</li> </ul>
<b>Ov-I</b>	000A	Overvoltage during acceleration	<ul style="list-style-type: none"> <li>• The input voltage fluctuates abnormally.</li> <li>(1) The power supply has a capacity of 200kVA or more.</li> <li>(2) A power factor improvement capacitor is opened or closed.</li> <li>(3) A system using a thyristor is connected to the same power distribution line.</li> <li>• A restart signal is input to the rotating motor after a momentary stop, etc.</li> </ul>	<ul style="list-style-type: none"> <li>• Insert a suitable input reactor.</li> <li>• Use <b>C-01</b> (auto-restart) and <b>C-02</b> (ride-through control).</li> </ul>

\* You can select a trip ON/OFF by parameters.

(Continued overleaf)

(Continued)

Error code	Failure code	Problem	Possible causes	Remedies
<b>OU-2</b>	000B	Overvoltage during deceleration	<ul style="list-style-type: none"> <li>• The deceleration time <b>U-08</b> is too short. (Regenerative energy is too large.)</li> <li>• <b>C-04</b> (dynamic braking resistor) is off.</li> <li>• <b>C-05</b> (overvoltage limit operation) is off.</li> <li>• The input voltage fluctuates abnormally.</li> </ul> <ol style="list-style-type: none"> <li>(1) The power supply has a capacity of 200kVA or more.</li> <li>(2) A power factor improvement capacitor is opened and closed.</li> <li>(3) A system using a thyrister is connected to the same power distribution line.</li> </ol>	<ul style="list-style-type: none"> <li>• Increase the deceleration time <b>U-08</b>.</li> <li>• Install a dynamic braking resistor.</li> <li>• Enable <b>C-04</b> (dynamic braking resistor).</li> <li>• Enable <b>C-05</b> (overvoltage limit operation).</li> <li>• Insert a suitable input reactor.</li> </ul>
<b>OU-3</b>	000C	Overvoltage during constant-speed operation	<ul style="list-style-type: none"> <li>• The input voltage fluctuates abnormally.</li> </ul> <ol style="list-style-type: none"> <li>(1) The power supply has a capacity of 200kVA or more.</li> <li>(2) A power factor improvement capacitor is opened or closed.</li> <li>(3) A system using a thyrister is connected to the same power distribution line.</li> </ol> <ul style="list-style-type: none"> <li>• The motor is in a regenerative state because the load causes the motor to run at a frequency higher than the inverter output frequency.</li> </ul>	<ul style="list-style-type: none"> <li>• Insert a suitable input reactor.</li> <li>• Install a dynamic braking resistor.</li> </ul>
<b>OL-1</b>	000D	Inverter overload	<ul style="list-style-type: none"> <li>• The acceleration time <b>U-07</b> is too short.</li> <li>• The DC braking amount is too large.</li> <li>• The V/F setting is improper.</li> <li>• A restart signal is input to the rotating motor after a momentary stop, etc.</li> <li>• The load is too large.</li> </ul>	<ul style="list-style-type: none"> <li>• Increase the acceleration time <b>U-07</b>.</li> <li>• Reduce the DC braking amount <b>b-5</b> and the DC braking time <b>b-52</b>.</li> <li>• Check the V/F parameter setting.</li> <li>• Use <b>C-01</b> (auto-restart) and <b>C-02</b> (ride-through control).</li> <li>• Use an inverter with a larger rating.</li> </ul>

\* You can select a trip ON/OFF by parameters.

(Continued overleaf)

(Continued)

Error code	Failure code	Problem	Possible causes	Remedies
<b>OL-2</b>	000E	Motor overload	<ul style="list-style-type: none"> <li>• The V/F setting is improper.</li> <li>• The motor is locked up.</li> <li>• Low-speed operation is performed continuously.</li> <li>• An excessive load is applied to the motor during operation.</li> </ul>	<ul style="list-style-type: none"> <li>• Check the V/F parameter setting.</li> <li>• Check the load (operated machine).</li> <li>• Adjust <b>U-17</b> to the overload that the motor can withstand during operation in a low speed range.</li> </ul>
<b>OL-r</b>	000F	Dynamic braking resistor overload trip	<ul style="list-style-type: none"> <li>• The deceleration time is too short.</li> <li>• Dynamic braking is too large.</li> </ul>	<ul style="list-style-type: none"> <li>• Increase the deceleration time <b>U-08</b>.</li> <li>• Increase the capacity of dynamic braking resistor (wattage) and adjust PBR capacity parameter <b>C-08</b>.</li> </ul>
* <b>OL-1</b>	0020	Over-torque trip	<ul style="list-style-type: none"> <li>• Over-torque reaches to a detection level during operation.</li> </ul>	<ul style="list-style-type: none"> <li>• Enable <b>F-15</b> (over-torque trip selection).</li> <li>• Check system error.</li> </ul>
<b>OH-1</b>	0010	Overheat	<ul style="list-style-type: none"> <li>• The cooling fan does not rotate.</li> <li>• The ambient temperature is too high.</li> <li>• The vent is blocked up.</li> <li>• A heat generating device is installed close to the inverter.</li> <li>• The thermistor in the unit is broken.</li> </ul>	<ul style="list-style-type: none"> <li>• Restart the operation by resetting the inverter after it has cooled down enough.</li> <li>• The fan requires replacement if it does not rotate during operation.</li> <li>• Secure sufficient space around the inverter.</li> <li>• Do not place any heat generating device near the inverter.</li> <li>• Make a service call.</li> </ul>
<b>OH-2</b>	002E	External thermal trip	<ul style="list-style-type: none"> <li>• An external thermal trip is input.</li> </ul>	<ul style="list-style-type: none"> <li>• Check the external thermal input.</li> </ul>
<b>ESOP</b>	0011	Emergency stop	<ul style="list-style-type: none"> <li>• During automatic operation or remote operation, a stop command is entered from the operation panel or a remote input device.</li> </ul>	<ul style="list-style-type: none"> <li>• Reset the inverter.</li> </ul>
<b>CPF5</b>	0012	EEPROM fault 1	<ul style="list-style-type: none"> <li>• A data writing error occurs.</li> </ul>	<ul style="list-style-type: none"> <li>• Turn off the inverter, then turn it again. If it does not recover from the error, make a service call.</li> </ul>
<b>CPF6</b>	0013	EEPROM fault 2	<ul style="list-style-type: none"> <li>• Power supply is cut off during <b>U-05</b> operation and data writing is aborted.</li> </ul>	<ul style="list-style-type: none"> <li>• Turn the power off temporarily and turn it back on, and then try <b>U-05</b> operation again.</li> </ul>
<b>CPF7</b>	0014	EEPROM fault 3	<ul style="list-style-type: none"> <li>• A data reading error occurred.</li> </ul>	<ul style="list-style-type: none"> <li>• Turn off the inverter, then turn it again. If it does not recover from the error, make a service call.</li> </ul>
<b>CPF3</b>	0015	Main unit RAM fault	<ul style="list-style-type: none"> <li>• The control RAM is defective.</li> </ul>	<ul style="list-style-type: none"> <li>• Make a service call.</li> </ul>
<b>CPF4</b>	0016	Main unit ROM fault	<ul style="list-style-type: none"> <li>• The control ROM is defective.</li> </ul>	<ul style="list-style-type: none"> <li>• Make a service call.</li> </ul>
<b>CPF0</b>	0017	CPU fault 1	<ul style="list-style-type: none"> <li>• The control CPU is defective.</li> </ul>	<ul style="list-style-type: none"> <li>• Make a service call.</li> </ul>

\* You can select a trip ON/OFF by parameters.

(Continued overleaf)

(Continued)

Error code	Failure code	Problem	Possible causes	Remedies
<b>CE-1</b>	0018	Remote control error	<ul style="list-style-type: none"> <li>An error arises during remote operation.</li> </ul>	<ul style="list-style-type: none"> <li>Check the remote control device, cables, etc.</li> </ul>
<b>CPF8</b>	001A	Current detector fault	<ul style="list-style-type: none"> <li>The current detector is defective.</li> </ul>	<ul style="list-style-type: none"> <li>Make a service call.</li> </ul>
<b>OPE1</b>	001B	Optional circuit board format error	<ul style="list-style-type: none"> <li>An optional circuit board in a different format is installed.</li> </ul>	<ul style="list-style-type: none"> <li>Check again to be sure that the circuit board is connected correctly, and then reset the power supply.</li> <li>Replace the circuit board with a correctly formatted one.</li> </ul>
<b>CPF9</b>	001D	Low-current operation Trip	<ul style="list-style-type: none"> <li>The output current decreased to a low-current detection level during operation.</li> </ul>	<ul style="list-style-type: none"> <li>Enable <b>F-10</b> (low-current detection).</li> <li>Check the suitable detection level for the system (<b>F-11</b>, <b>F-12</b>).</li> <li>Make a service call if the setting is correct.</li> </ul>
<b>Uu-1</b>	001E	Undervoltage trip (main circuit)	<ul style="list-style-type: none"> <li>The input voltage (in the main circuit) is too low.</li> </ul>	<ul style="list-style-type: none"> <li>Check the input voltage.</li> <li>Enable <b>F-27</b> (undervoltage trip selection).</li> <li>To cope with a momentary stop due to undervoltage, enable <b>C-02</b> (ride-through control) and <b>C-01</b> (auto-restart).</li> </ul>
<b>GF-1</b>	0022	Ground fault trip	<ul style="list-style-type: none"> <li>A ground fault occurs in the output cable or the motor.</li> </ul>	<ul style="list-style-type: none"> <li>Check the cable and the motor for ground faults.</li> </ul>
<b>ATE1</b>	0054	Auto-tuning error	<ul style="list-style-type: none"> <li>Check the motor parameter <b>d-01</b> to <b>d-94</b>.</li> <li>The motor with the capacity of 2 classes or less than the inverter is used.</li> <li>The output cable is too thin.</li> <li>The motor is rotating.</li> <li>The inverter is used for loads other than those of three-phase induction motors.</li> </ul>	
<b>OPE2</b>	0029	Inverter type error	<ul style="list-style-type: none"> <li>Circuit board is changed. (Or main circuit/drive circuit board)</li> </ul>	<ul style="list-style-type: none"> <li>Make a service call.</li> </ul>
<b>RIE1</b>	0032	Brea in analog signal cable	<ul style="list-style-type: none"> <li>The signal input via VIA is below the analog signal detection level set with <b>F-33</b>.</li> </ul>	<ul style="list-style-type: none"> <li>Check the cables for breaks. And check the setting of input signal or setting value of <b>F-33</b>.</li> </ul>
<b>CE-2</b>	0033	CPU communications error	<ul style="list-style-type: none"> <li>A communications error occurs between control CPUs.</li> </ul>	<ul style="list-style-type: none"> <li>Make a service call.</li> </ul>
<b>OPE3</b>	0034	Excessive torque boosted	<ul style="list-style-type: none"> <li>The torque boost parameter <b>d-02</b> is set too high.</li> <li>The motor has too small impedance.</li> </ul>	<ul style="list-style-type: none"> <li>Decrease the setting of the torque boost parameter <b>d-02</b>.</li> </ul>
<b>CPF2</b>	0035	CPU fault 2	<ul style="list-style-type: none"> <li>The control CPU is defective.</li> </ul>	<ul style="list-style-type: none"> <li>Make a service call.</li> </ul>
<b>PNE1</b>	002F	Step-out (For PM motor only)	<ul style="list-style-type: none"> <li>The motor shaft is locked.</li> <li>One output phase is open.</li> <li>An impact load is applied.</li> </ul>	<ul style="list-style-type: none"> <li>Unlock the motor shaft.</li> <li>Check the interconnect cables between the inverter and the motor.</li> </ul>

\* You can select a trip ON/OFF by parameters.

[Alarm information] Each message in the table is displayed to give a warning but does not cause the inverter to trip

Error code	Problem	Possible causes	Remedies
<b>OFF</b>	ST terminal OFF	· The ST-CC circuit is opened.	· Close the ST-CC circuit.
<b>NOFF</b>	Undervoltage in main circuit	· The supply voltage between R, S and T is under voltage.	· Measure the main circuit supply voltage. If the voltage is at a normal level, the inverter requires repairing.
<b>rtry</b>	Retry in process	· The inverter is in the process of retry. · A momentary stop occurred.	· The inverter is normal if it restarts after several tens of seconds. The inverter restarts automatically. Be careful of the machine because it may suddenly restart.
<b>Err 1</b>	Frequency point setting error alarm	· The frequency setting signals at points 1 and 2 are set too close to each other.	· Set the frequency setting signals at points 1 and 2 apart from each other.
<b>CLAr</b>	Clear command acceptable	· This message is displayed when pressing the STOP key while an error code is displayed.	· Press the STOP key again to clear the trip.
<b>EOFF</b>	Emergency stop command acceptable	· The operation panel is used to stop the operation in automatic control or remote control mode.	· Press the STOP key for an emergency stop. To cancel the emergency stop, press any other key.
<b>H I / LO</b>	Setting error alarm / An error code and data are displayed alternately twice each.	· An error is found in a setting when data is reading or writing.	· Check whether the setting is made correctly.
<b>HEAd / End</b>	Display of first/last data items	· The first and last data item in the RUH data group is displayed.	· Press MODE key to exit the data group.
<b>db</b>	DC braking	· DC braking in process	· The message goes off in several tens of seconds if no problem occurs. (Note)
<b>dbOn</b>	Shaft fixing control	· Motor shaft fixing control is in process.	· Normal if the message disappears when a stop command is entered (or the operation command is canceled).
<b>E1 E2 E3</b>	Flowing out of excess number of digits	· The number of digits such as frequencies is more than 4. (The upper digits have a priority.)	· Lower the frequency free unit magnification <b>H-02</b> .
<b>StOP</b>	Momentary power failure slowdown stop prohibition function activated.	· The slowdown stop prohibition function set with <b>C-02</b> (momentary power failure ride-through operation) is activated.	· To restart operation, reset the inverter or input an operation signal again.
<b>LStP</b>	Auto-stop because of continuous operation at the lower-limit frequency	· The automatic stop function selected with <b>b-56</b> was activated.	· To deactivate the automatic stop function, increase the frequency command above the lower-limit frequency (LL) + 0.2 Hz or turn off the operation command.
<b>In It</b>	Parameters in the process of initialization	· Parameters are being initialized to default values.	· Normal if the message disappears after a while (several seconds to several tens of seconds).
<b>Er 17</b>	Operation panel key fault	· The RUN or STOP key is held down for more than 20 seconds. · The RUN or STOP key is faulty.	· Check the operation panel.
<b>Atn 1</b>	Auto-tuning	· Auto-tuning in process	· Normal if the message disappears after a few seconds.

Note) When the ON/OFF function is selected for DC braking ( DB ), using the input terminal selection parameter, you can judge the inverter to be normal if “ db ” disappears when opening the circuit between the terminal and CC.

[Prealarm display]

<b>C</b>	Overcurrent alarm	Same as <b>OC</b> (overcurrent)
<b>P</b>	Overvoltage alarm	Same as <b>OP</b> (overvoltage)
<b>L</b>	Overload alarm	Same as <b>OL - 1</b> and <b>OL - 2</b> (overload)
<b>H</b>	Overheat alarm	Same as <b>OH - 1</b> (overheat)

If two or more problems arise simultaneously, one of the following alarms appears and blinks.

**C,P,L,CPL**

The blinking alarms **C,P,L,H** are displayed in this order from left to right.

## 9.2 Restoring the inverter from a trip.

Do not reset the inverter when tripped because of a failure or error before eliminating the cause. Resetting the tripped inverter before eliminating the problem causes it to trip again

The inverter can be restored from a trip by any of the following operations:

- (1) By turning off the power (Keep the inverter off until the LED turns off.)  
Note) Refer to 7.15.3 (inverter trip retention selection **F-02** ) for details.
- (2) By means of an external signal (Short circuit between RES and CC on terminal board→Open)
- (3) By operation panel operation
- (4) By inputting a trip clear signal from a remote input device  
(Refer to the remote input device operating manual for details.)

To reset the inverter by operation panel operation, follow these steps.

1. Press the STOP key and make sure that **CLAr** is displayed.
2. Pressing the STOP key again will reset the inverter if the cause of the trip has already been eliminated.

☆ When any overload function [**OL - 1** : inverter overload, **OL - 2** : motor overload, **OL - r** : braking resistor overload] is active, the inverter cannot be reset by inputting a reset signal from an external device or by operation panel operation before the virtual cooling time has passed.

Virtual cooling time ... **OL-1** :about 30 seconds after occurrence of a trip  
**OL-2** :about 120 seconds after a occurrence of a trip  
**OL-r** :about 20 seconds after a occurrence of a trip

- ☆ In case of a trip due to overheating (**OH-1**), the inverter checks the temperature within. Wait until the temperature in the inverter falls sufficiently before resetting the inverter.

[Caution]

Turning the inverter off then turning it on again resets the inverter immediately. You can use this mode of resetting if there is a need to reset the inverter immediately. Note, however, that this operation may damage the system or the motor if it is repeated frequently.

## 9.3 If the motor does not run while no trip message is displayed ...

If the motor does not run while no trip message is displayed, follow these steps to track down the cause.

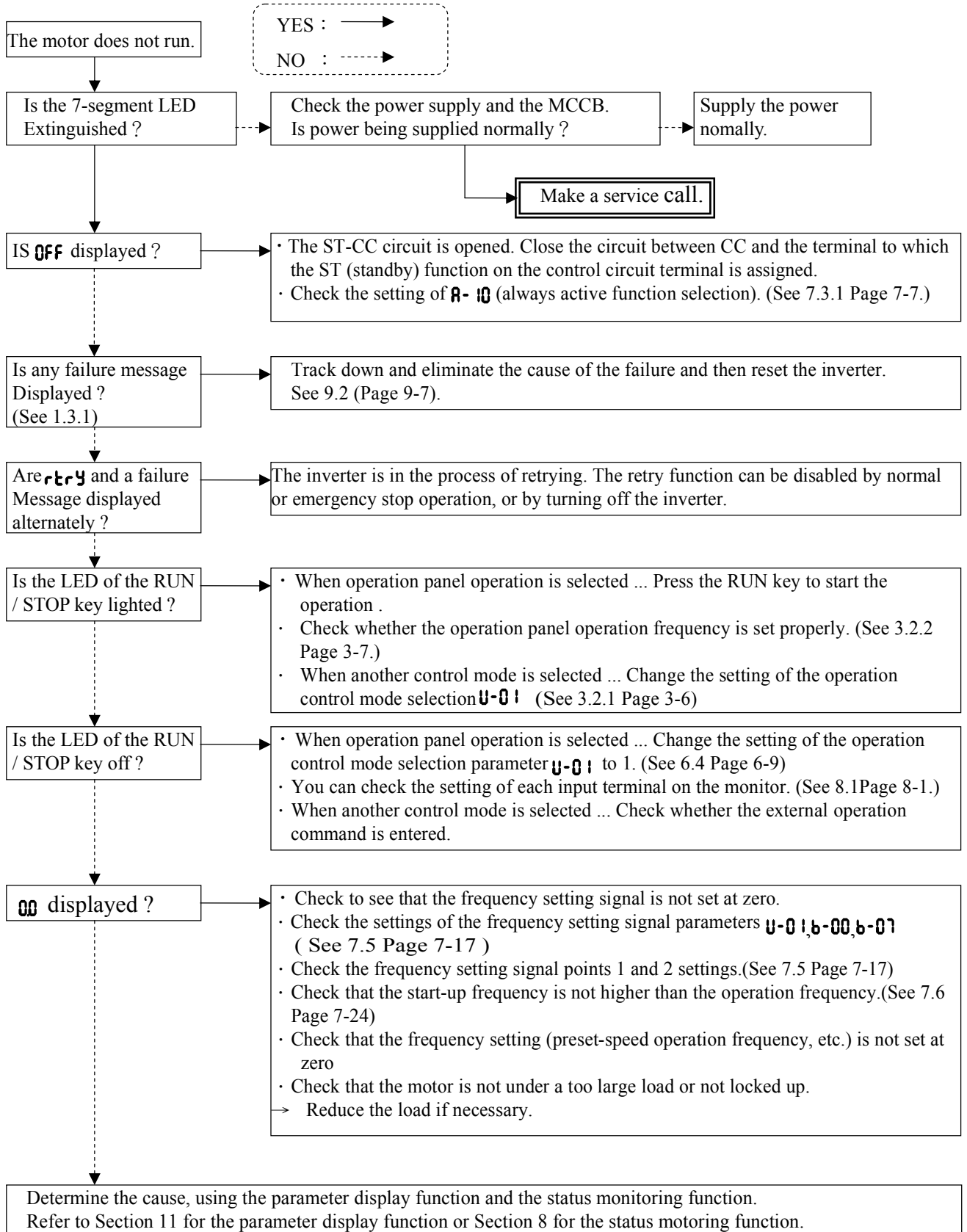

## 9.4 How to determine the causes of other problems

The following table provides a listing of other problems, their possible causes and remedies.



Problems	Causes and remedies
The motor runs in the wrong direction.	<ul style="list-style-type: none"> <li>• Invert the phases of the output terminals U, V and W.</li> <li>• Invert the forward/reverse run-signal terminals of the external input device. (See 7.3 “Assignment of functions to control terminals”.)</li> <li>• Change the setting of the parameter <b>U-06</b> in the case of panel operation.</li> </ul>
The motor runs but its speed does not change normally.	<ul style="list-style-type: none"> <li>• The load is too heavy. Reduce the load.</li> <li>• The soft stall function is activated. Disable the soft stall function. (See 6.14 Page 6-30.)</li> <li>• The maximum frequency <b>U-09</b> and the upper limit frequency <b>U-10</b> are set too low. Increase the maximum frequency <b>U-09</b> and the upper limit frequency <b>U-10</b>.</li> <li>• The frequency setting signal is too low. Check the signal set value, circuit, cables, etc.</li> <li>• Check the setting characteristics (point 1 and point 2 settings) of the frequency setting signal parameters. (See 7.5 Page 7-17.)</li> <li>• If the motor runs at a low speed, check to see that the stall prevention function is activated because the torque boost amount is too large. Adjust the torque boost amount (<b>U-15</b>) and the acceleration time (<b>U-07</b>). (See 6.12 Page 6-25 and 6.1 Page 6-1.)</li> </ul>
The motor does not accelerate or decelerate smoothly.	<ul style="list-style-type: none"> <li>• The acceleration time (<b>U-07</b>) or the deceleration time (<b>U-08</b>) is set too short. Increase the acceleration time (<b>U-07</b>) or the deceleration time (<b>U-08</b>).</li> </ul>
A too large current flows into the motor.	<ul style="list-style-type: none"> <li>• The load is too heavy. Reduce the load.</li> <li>• If the motor runs at a low speed, check whether the torque boost amount is too large. (See 6.12 Page 6-25.)</li> </ul>
The motor runs at a higher or lower speed than the specified one.	<ul style="list-style-type: none"> <li>• The motor has an improper voltage rating. Use a motor with a proper voltage rating.</li> <li>• The motor terminal voltage is too low. Check the setting of the base frequency voltage parameter (<b>U-13</b>). (See 7.13.6 Page 7-44.) Replace the cable with a cable larger in diameter.</li> <li>• The reduction gear ratio, etc., are not set properly. Adjust the reduction gear ratio, etc.</li> <li>• The output frequency is not set correctly. Check the output frequency range.</li> <li>• Adjust the base frequency. (See 6.10 Page 6-18.)</li> </ul>

Problems	Causes and remedies
The motor speed fluctuates during operation.	<ul style="list-style-type: none"> <li>• The load is too heavy or too light. Reduce the load fluctuation.</li> <li>• The inverter or motor used does not have a rating large enough to drive the load. Use an inverter or motor with a rating large enough.</li> <li>• Check whether the frequency setting signal changes.</li> <li>• If the V/F control selection parameter <b>U-14</b> is set at 3, check the vector control setting, operation conditions, etc. (See 6.11 Page 6-18.)</li> </ul>
Parameter settings cannot be changed.	<p>Change the setting of the parameter <b>H-00</b> (prohibition of change of parameter setting) to <b>0</b> (permitted) if it is set at <b>1</b> (prohibited).</p> <p>* For reasons of safety, some parameters cannot be reprogrammed while the inverter is running.</p>

#### How to cope with parameter setting-related problems

If you forget parameters which have been reset	<ul style="list-style-type: none"> <li>• You can search for all reset parameters and change their settings.</li> </ul>
If you want to return all reset parameters to their respective default settings	<ul style="list-style-type: none"> <li>• You can return all parameters which have been reset to their default settings.</li> </ul>

# 10. Inspection and maintenance

 Danger	
 Mandatory	<ul style="list-style-type: none"> <li>· The equipment must be inspected every day. If the equipment is not inspected and maintained, errors and malfunctions may not be discovered which could lead to accidents.</li> <li>· Before inspection, perform the following steps.             <ol style="list-style-type: none"> <li>(1) Shut off all input power to the inverter.</li> <li>(2) Wait at least ten minutes and check to make sure that the charge lamp is no longer lit.</li> <li>(3) Use a tester that can measure DC voltages (800V DC or more), and check that the voltage to the DC main circuits (across PA-PC) does not exceed 45V.</li> </ol> </li> </ul> <p>Performing an inspection without carrying out these steps first could lead to electric shock.</p>

Be sure to inspect the inverter regularly and periodically to prevent it from breaking down because of the environment of use, such as temperature, humidity, dust and vibration, or deterioration of its components with aging.

## 10.1 Regular inspection

Since electronic parts are susceptible to heat, install the inverter in a cool, well-ventilated and dust-free place. This is essential for increasing the service life. The purpose of regular inspections is to maintain the correct environment of use and to find any sign of failure or malfunction by comparing current operation data with past operation records.

Subject of inspection	Inspection procedure			Criteria for judgment
	Inspection item	Inspection cycle	Inspection method	
1. Indoor environment	1) Dust, temperature and gas	Occasionally	1) Visual check, check by means of a thermometer, smell check	1) Improve the environment if it is found to be unfavorable. 2) Check for any trace of water condensation. 3) Max. temperature: 60°C
	2) Drop of water or other liquid	Occasionally	2) Visual check	
	3) Room temperature	Occasionally	3) Check by means of a thermometer	
2. Units and components	1) Vibration and noise	Occasionally	Tactile check of the cabinet	Is something unusual is found, open the door and check the transformer, reactors, contactors, relays, cooling fan, etc., inside. If necessary, stop the operation.
3. Operation data (output side)	1) Load current	Occasionally	Moving-iron type AC ammeter	To be within the rated current, voltage and temperature. No significant difference from data collected in a normal state.
	2) Voltage (*)	Occasionally	Rectifier type AC voltmeter	
	3) Temperature	Occasionally	Thermometer	



- \*) The voltage measured may slightly vary from voltmeter to voltmeter. When measuring the voltage, always take readings from the same circuit tester or voltmeter.

■ Check points

1. Something unusual in the installation environment
2. Something unusual in the cooling system
3. Unusual vibration or noise
4. Overheating or discoloration
5. Unusual odor
6. Unusual motor vibration, noise or overheating
7. Adhesion or accumulation of foreign substances (conductive substances)

## 10.2 Periodical inspection

Make a periodical inspection at intervals of 3 or 6 months depending on the operating conditions

 Danger	
 Mandatory	<ul style="list-style-type: none"> <li>· Before inspection, perform the following steps.</li> <li>(1) Shut off all input power to the inverter.</li> <li>(2) Wait at least ten minutes and check to make sure that the charge lamp is no longer lit.</li> <li>(3) Use a tester that can measure DC voltages (800V DC or more), and check that the voltage to the DC main circuits (across PA-PC) does not exceed 45V.</li> </ul> <p>Performing an inspection without carrying out these steps first could lead to electric shock.</p>
 Prohibited	<ul style="list-style-type: none"> <li>· Never replace any part.</li> </ul> <p>This could be a cause of electric shock, fire and bodily injury. To replace parts, call the local sales agency.</p>

■ Check items

1. Check to see if all screwed terminals are tightened firmly. If any screw is found loose, tighten it again with a screwdriver.
2. Check to see if all caulked terminals are fixed properly. Check them visually to see that there is no trace of overheating around any of them.
3. Check all cables and wires for damage. Check them visually.
4. Remove dirt and dust. With a vacuum cleaner, remove dirt and dust. When cleaning, clean the vents and the printed circuit boards. Always keep them clean to prevent an accident due to dirt or dust.

5. If no power is supplied to the inverter for a long time, the performance of its large-capacity electrolytic capacitor declines.

When leaving the inverter unused for a long time, supply it with electricity once every two years, for 5 hours or more each, to recover the performance of the large-capacity electrolytic capacitor. And also check the function of the inverter. It is advisable not to supply the commercial power directly to the inverter but to gradually increase the power supply voltage with a transformer, etc

6. If the need arises, conduct an insulation test on the main circuit terminal board only, using a 500V insulation tester. Never conduct an insulation test on control terminals other than terminals on the printed circuit board or on control terminals. When testing the motor for insulation performance, separate it from the inverter in advance by disconnecting the cables from the inverter output terminals U, V and W. When conducting an insulation test on peripheral circuits other than the motor circuit, disconnect all cables from the inverter so that no voltage is applied to the inverter during the test.

(Note) Before an insulation test, always disconnect all cables from the main circuit terminal board and test the inverter separately from other equipment.

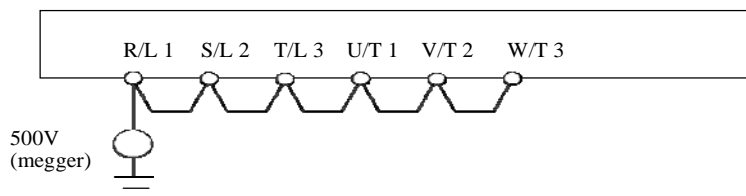

7. Never test the inverter for pressure. A pressure test may cause damage to its components.

8. Voltage and temperature check

Recommended voltmeter : Input side ... Moving-iron type

Voltmeter 

Output side ... Rectifier type

voltmeter 

It will be very helpful for detecting a defect if you always measure and record the ambient temperature before, during and after the operation.

## ■ Replacement of expendable parts

The inverter is composed of a large number of electronic parts including semiconductor devices. The following parts deteriorate with the passage of time because of their composition or physical properties. The use of aged or deteriorated parts leads to degradation in the performance or a breakdown of the inverter. To avoid such trouble, the inverter should be checked periodically.

Note) Generally, the life of a part depends on the ambient temperature and the conditions of use. The life spans listed below are applicable to parts when used under normal environmental conditions.

### 1) Cooling fan

The fan, which cools down heat-generating parts, has a service life of about 30,000 hours (about 2 or 3 years of continuous operation). The fan also needs to be replaced if it makes a noise or vibrates abnormally.

### 2) Smoothing capacitor

The smoothing aluminum electrolytic capacitor in the main circuit DC section degrades in performance because of ripple currents, etc. It becomes necessary to replace the capacitor after it is used for about 5 years under normal conditions. Since the smoothing capacitor is mounted on a printed circuit board, it needs to be replaced together with the circuit board.

<Criteria for appearance check>

- Absence of liquid leak
- Safety valve in the depressed position
- Measurement of electrostatic capacitance and insulation resistance

Note: The operation time is helpful for roughly determining the time of replacement. For the replacement of parts, contact your nearest Toshiba inverter distributor. For safety's sake, never replace any part on your own. (Parts replacement alarms can be known by monitor and alarm output, if it is set. Refer to section 7.19.14 Page 7-73)

## ■ Standard replacement cycles of principal parts

As guides, the table below lists part replacement cycles that were estimated based on the assumption that the inverter would be used in a normal use environment under normal conditions (ambient temperature, ventilation

conditions, and energizing time). The replacement cycle of each part does not mean its service life but the number of years over which its failure rate does not increase significantly.

Part name	Standard replacement cycle	Replacement mode and others
Cooling fan	2 to 3 years	Replacement with a new one
Main circuit smoothing aluminum electrolytic capacitor	5 years	Replacement with a new one
Relay and contactor	-	Whether to replace or not depends on the check results
Aluminum electrolytic capacitor mounted on a printed circuit board	5 years	Replace with a new circuit board

Note) The life of a part greatly varies depending on the environment of use.

### 10.3 Making a call for servicing

For the Rich service network, refer to the back cover of this instruction manual. If defective conditions are encountered, please contact the Rich service section in charge via your Rich dealer.

When making a call for servicing, please inform us of the contents of the rating label on the right panel of the inverter, the presence or absence of optional devices, etc., in addition to the details of the failure.

### 10.4 Keeping the inverter in storage

Take the following precautions when keeping the inverter in storage temporarily or for a long period of time.

1. Store the inverter in a well-ventilated place away from heat, damp, dust and metal powder.
2. If the printed circuit board in your inverter has an anti-static cover (black cover), do not leave it detached from the circuit board during storage. The cover must be detached before turning on the inverter.
3. If no power is supplied to the inverter for a long time, the performance of its large-capacity electrolytic capacitor declines.

When leaving the inverter unused for a long time, supply it with electricity once every two years, for 5 hours or more each, to recover the performance of the large-capacity electrolytic capacitor. And also check the function of

the inverter. It is advisable not to supply the commercial power directly to the inverter but to gradually increase the power supply voltage with a transformer, etc.